

**TERUFLEX BLOOD WITH DIVERSION BLOOD SAMPLING ARM 70 ML CPDA-1-anhydrous citric acid, trisodium citrate dihydrate, sodium phosphate, monobasic, monohydrate, dextrose monohydrate, and adenine solution
Terumo Corporation**

**TERUFLEX™ BLOOD BAG SYSTEM with Diversion Blood Sampling Arm™
CPDA-1 SOLUTION**

For the collection of 450 mL or 500 mL of Whole Blood

Rev. 2020-09

N-BB-CA-A-DB ④

FULL PRESCRIBING INFORMATION

*Sections or subsections omitted from the Full Prescribing Information are not listed [includes sections 4, 6, 7, 8, 9, 10, 12, 13, 14, 15 and 17].

1. INDICATIONS AND USAGE

- 1.1. Read these instructions carefully before use.
- 1.2. Rx ONLY.
- 1.3. Intended for the collection, processing and preservation of Whole Blood and blood components. Not intended for direct intravenous infusion.
- 1.4. For the collection of 450 mL \pm 10% or 500 mL \pm 10% Whole Blood.
- 1.5. Integral Diversion Blood Sampling Arm is intended to divert and obtain donor samples for laboratory testing prior to collection of the Whole Blood unit.
- 1.6. For further processing, use standard component processing techniques.

2. DOSAGE AND ADMINISTRATION

- 2.1. To open blister package, peel cover film back 4/5 of its length.
- 2.2. Prepare the blood bag following your institution's standard operating procedures.
 - 2.2.1. Materials Needed:
 - VENOJECT II Tube Holder (code P-1316R) or equivalent
 - VENOJECT II Multi-Sample Luer Adapter (code MN*2000T) or equivalent
 - Evacuated blood collection tubes (glass or plastic)
- 2.3. Make a loose knot in the donor tubing below the "Y" and CLIKTIP (inline closure device) unless alternate methods are used to seal the tubing at the end of collection.
- 2.4. Temporarily clamp donor tubing between the phlebotomy needle and the "Y".
- 2.5. Close the White Clamp below the diversion pouch.
- 2.6. Assemble the luer adapter and the tube holder.
 - 2.6.1. Connect the VENOJECT II Multi-Sample Luer Adapter to the VENOJECT II Tube

Holder (or equivalent) (Fig. 1).

2.6.2. Twist and snap to remove the blue port cap at the end of the Diversion Blood Sampling Arm (Fig. 2a).

2.6.3. Insert the Holder/Luer assembly in the female luer port (Fig. 2b).

2.6.4. NOTE: Alternatively, steps 2.6.1., 2.6.2., and 2.6.3. (above) may be performed at any time during bag preparation or after the blood is collected into the diversion pouch.

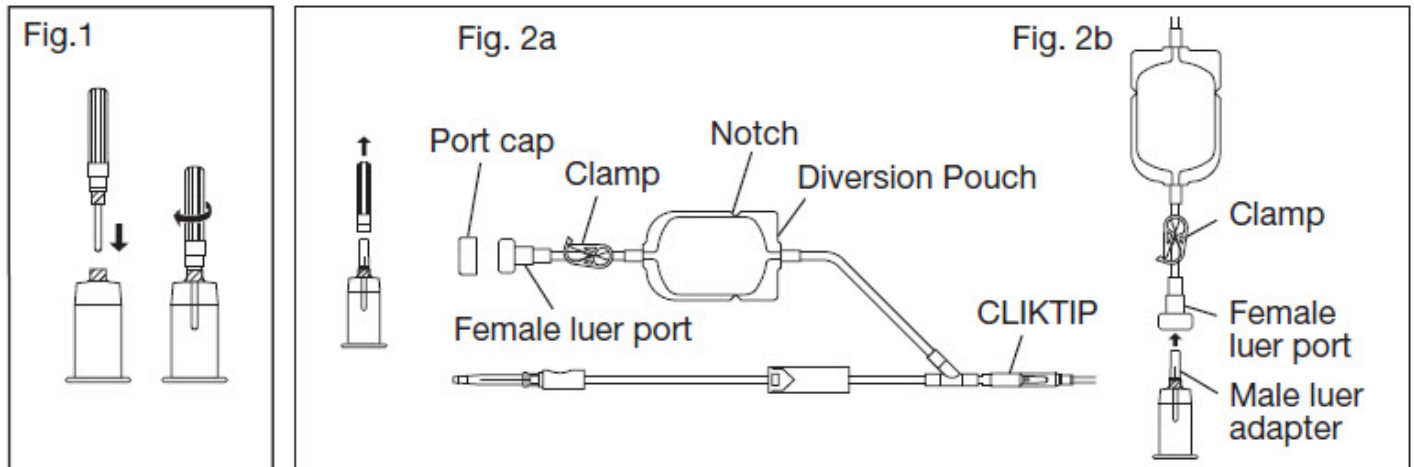

2.7. Suspend the collection bag as far as possible below the donor's arm.

2.8. Apply blood pressure cuff or tourniquet to donor's arm. Disinfect site of phlebotomy according to institutional standard operating procedures. If blood pressure cuff is used, inflate to approximately 60 mmHg.

2.9. Remove the needle cover and perform phlebotomy. Remove the temporary clamp on the donor tubing to permit blood flow into the Diversion Blood Sampling Arm pouch.

2.9.1. **CAUTION:** Do not touch the needle after removing the needle cover.

2.9.2. **CAUTION:** Assure that the White Clamp below the pouch is closed prior to initiating phlebotomy.

2.10. Secure the needle safety device in place following the device instructions provided on the reverse side.

2.11. Secure donor tubing to donor's arm.

2.12. Position the diversion pouch with the notches up and the Tube Holder/Luer Adapter assembly (or port cap) down. When the level of blood in the pouch is approximately in line with the notches, the diversion pouch is full (Fig. 3a).

2.12.1. **NOTE:** The approximate fill volume of the pouch at the notches is 35 mL.

2.13. Permanently seal the tubing between the "Y" and the diversion pouch to maintain a closed system using an aluminum clip or a tube sealer approved for use with tubing connected to a donor (Fig. 3b).

2.13.1. **CAUTION:** Do not use a dielectric tube sealer to seal the tubing while the needle is connected to the donor's body unless it is approved for such a purpose.

2.14. To initiate blood flow into the collection bag, break the CLIKTIP between the "Y" and the collection bag.

2.15. To avoid clot formation, collect samples as soon as possible from the diversion pouch as follows (Fig. 3b).

2.15.1. **CAUTION:** Do not collect donor test samples until the tubing between the "Y" and the diversion pouch is permanently sealed.

2.15.2. Open the White Clamp on the tubing below the pouch to open the pathway for sampling.

2.15.3. Position the diversion pouch with the notches up and the Tube Holder/Luer Adapter assembly downward. Assure that any air in the pouch is at the top and will not enter the blood collection tubes.

2.15.4. Insert blood collection tube firmly into the tube holder; when full, remove sample tube from holder. Repeat to collect additional samples.

2.15.5. **NOTE:** The pouch may be removed after the donor test samples are collected. A second seal must be made between the diversion pouch and the permanent seal prior to removing the pouch.

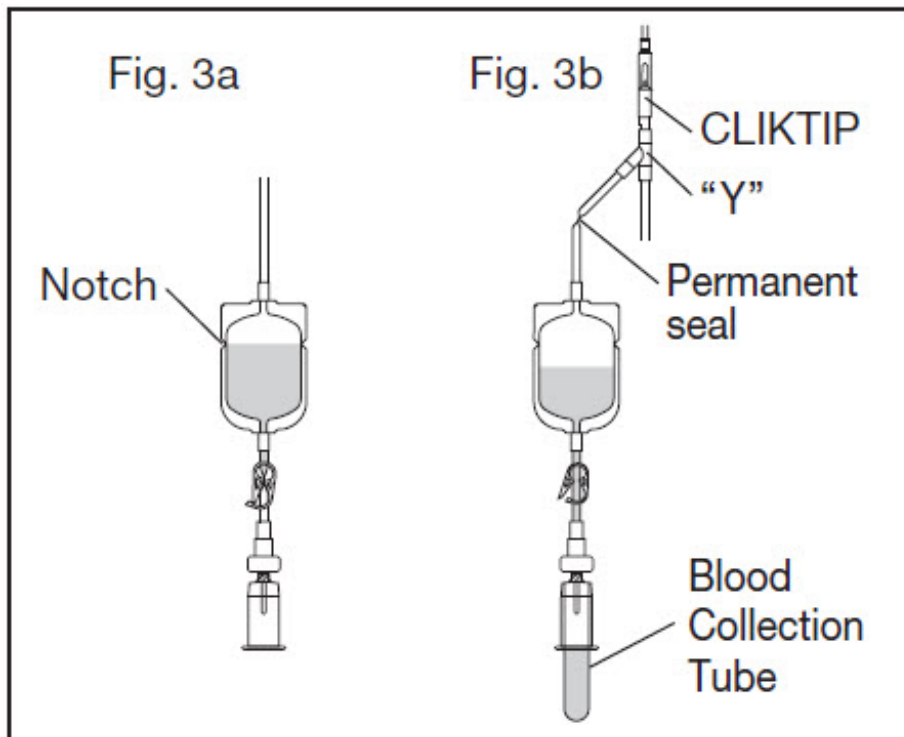

2.16. Mix blood with anticoagulant in the collection bag and continue to mix at several intervals during collection and immediately after collection. If using an automated mixer, follow manufacturer's instructions.

2.17. Collect labeled volume of blood 450 mL \pm 10% or 500 mL \pm 10%.

2.18. When the desired amount of blood has been collected, seal the tubing or tighten the loose knot (white knot) prepared in Step 2.3. Make a second seal between the first seal or knot and the "Y". Various methods may be used to seal tubing.

2.19. Release pressure on the donor's arm and remove the needle into the needle safety device following the device instructions provided on the reverse side. Sever the donor tubing between the two seals previously made below the CLIKTIP and "Y".

2.19.1. **CAUTION:** Discard the Diversion Blood Sampling Arm and phlebotomy

needle/donor tubing according to institutional standard operating procedures.

2.20. Strip blood from donor tubing into collection bag, mix well, and allow tubing to refill; repeat once. To prevent the blood from clotting in the tubing, work quickly as possible. Make an appropriate number of segments of anticoagulated blood for testing by sealing on or near the X marks. Leave segments attached to the Whole Blood unit.

2.21. The time between Whole Blood collection and component separation may vary depending on both the blood bag system and processing options selected. Follow your institution's standard operating procedures to prepare components.

2.21.1. If the Whole Blood is to be processed into room temperature components, maintain the blood at ambient temperature.

2.21.2. If the Whole Blood is to be processed into other components (including Plasma Frozen Within 24 Hours After Phlebotomy), Whole Blood must either be placed in storage at a temperature between 1-6°C within 8 hours of blood collection or cooled towards a temperature between 1-10°C (e.g. during transport) and then placed in storage at a temperature between 1-6°C upon arrival at the processing center.

2.22. Platelet Rich Plasma and Platelets should be separated from the Red Blood Cells within 8 hours of blood collection, if prepared.

2.23. Plasma intended for production of Fresh Frozen Plasma should be separated from the Red Blood Cells and placed in a freezer at -18°C or colder within 8 hours of blood collection.

2.24. Plasma intended for production of Plasma Frozen Within 24 Hours After Phlebotomy (PF24) should be placed in a freezer at -18°C or colder within 24 hours of blood collection.

2.25. For further preparation and processing of other plasma components, use standard processing and storage techniques following approved regulations and standards.

2.26. Select the appropriate spin condition and centrifuge Whole Blood unit to separate CPDA-1 Red Blood Cells from plasma or platelet rich plasma, as appropriate.

2.27. Break the CLIKTIP of primary collection bag and transfer plasma into satellite bag, or transfer platelet rich plasma into XT-612 Platelet bag. Clamp transfer tubing of satellite bag.

2.28. Seal tubing of primary collection bag in two places, cut between seals, and if applicable, separate from satellite bag(s).

2.29. Store CPDA-1 Red Blood Cells (or Whole Blood) between 1 - 6°C for up to 35 days.

2.30. If prepared, store Platelets between 20-24°C, maintaining a continuous gentle agitation, for up to 5 days in XT-612 bag.

3. DOSAGE FORMS AND STRENGTHS

3.1. 63 mL Citrate Phosphate Dextrose Adenine (CPDA-1) anticoagulant USP for collection of 450 mL Whole Blood. Each 63 mL contains 188 mg Citric Acid (anhydrous) USP, 1.66 g Sodium Citrate (dihydrate) USP, 140 mg Monobasic Sodium Phosphate

(monohydrate) USP, 2.01 g Dextrose (monohydrate) USP and 17.3 mg Adenine USP.

3.2. 70 mL Citrate Phosphate Dextrose Adenine (CPDA-1) anticoagulant USP for collection of 500 mL Whole Blood. Each 70 mL contains 209 mg Citric Acid (anhydrous) USP, 1.84 g Sodium Citrate (dihydrate) USP, 155 mg Monobasic Sodium Phosphate (monohydrate) USP, 2.23 g Dextrose (monohydrate) USP and 19.3 mg Adenine USP.

5. WARNINGS AND PRECAUTIONS

5.1. Rx ONLY.

5.2. Do not use unless solutions are clear and free from particulates.

5.3. Always inspect the blood bag set for leaks before use.

5.4. Avoid excessive heat and direct sunlight. Protect from freezing.

5.5. Recommended storage conditions: Room Temperature (15-30°C/59-86°F).

5.6. It is normal to have condensation in the blister packaging. If the amount of moisture is greater than expected, check for leaks from the fluid-filled components of the blood bag set.

5.7. Use aseptic techniques.

5.8. Do not use a dielectric tube sealer to seal the tubing while the needle is connected to the donor's body unless it is approved for such a purpose.

5.9. Do not touch needle after removing the needle cover.

5.10. Assure that the White Clamp below the pouch is closed prior to initiating phlebotomy.

5.11. Do not collect donor test samples until the tubing between the "Y" and the diversion pouch is permanently sealed.

5.12. Discard the Diversion Blood Sampling Arm and phlebotomy needle/donor tubing according to institutional standard operating procedures.

5.13. The AGELESS oxygen absorber packet, (Mitsubishi Gas Chemical) contained in this package absorbs oxygen and generates heat on removal. Do not open and handle it with care.

5.14. Dispose of the AGELESS packet with the blister tray.

5.15. Do not dispose the AGELESS packet with wastes containing volatile or flammable materials.

5.16. Due to possible exposure to infectious agents in the handling of blood, take adequate precautions at all times to prevent exposure to and transmission of such agents. Follow your institution's standard operating procedures.

11. DESCRIPTION / PRODUCT SPECIFICATIONS

11.1. This blood bag system includes a 16 gauge × 1 1/2 inch (1.60 × 38 mm) needle with needle cover and either a 450 mL or 500 mL (nominal capacity 600 mL) primary collection bag containing 63 mL or 70 mL, respectively, Citrate Phosphate Dextrose

Adenine (CPDA-1) anticoagulant. The Triple blood bag set has one integrally attached empty satellite bag (nominal capacity 400 mL) and one empty XT-612 5 day Platelet bag (nominal capacity 500 mL). The Quadruple blood bag set has two integrally attached empty satellite bags (nominal capacity 400 mL) and one empty XT-612 5 day Platelet bag (nominal capacity 500 mL).

11.2. Blood bag codes ending in A2 are supplied with Integral Diversion Blood Sampling Arm intended to divert and obtain donor samples for laboratory testing prior to collection of the Whole Blood unit.

11.3. Blood bag codes ending in A2 also include a DonorCare Needle Guard pre-attached to the donor tubing. DonorCare Needle Guard device instructions are provided on the reverse side.

11.4. The blood bag collection set is made of PVC (polyvinyl chloride with DEHP plasticizer).

11.5. The blood bag has no components made of natural rubber latex.

11.6. Tubing internal diameter (ID) nominal 3.0 mm.

11.7. Tubing outer diameter (OD) nominal 4.4 mm.

11.8. Donor tubing line maximum 16 segments available.

16. HOW SUPPLIED/STORAGE AND HANDLING

16.1. Single use only.

16.2. Sterile and non-pyrogenic fluid path. Sterilized by steam. Opacity of the blood bag system may be observed. This is due to moisture absorption during the sterilization process. This is normal and does not affect the solution quality or safety. The opacity will diminish gradually.

16.3. A Material Safety Data Sheet (MSDS) is not required for this product.

16.4. Recommended storage conditions: Room Temperature (15-30°C/59-86°F).

16.5. Avoid excessive heat and direct sunlight. Protect from freezing.

16.6. To open blister package, peel cover film back 4/5 of its length.

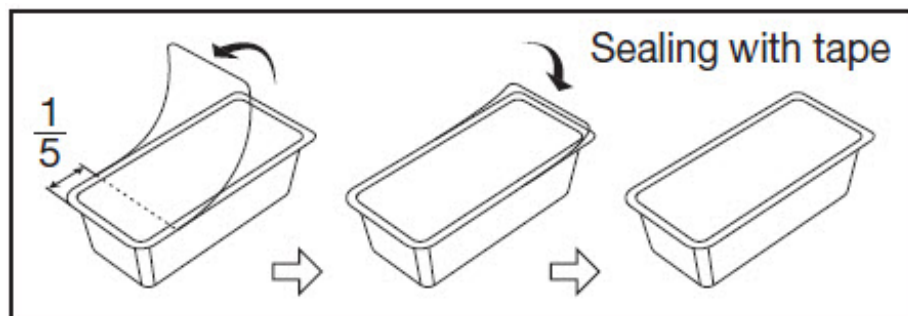

16.7. After opening the blister package, unused blood bags may be stored at room temperature for 96 hours or they may be stored for 30 days by returning cover film to original position and sealing with tape to prevent evaporation of solutions.

16.8. Blood bags in the unopened blister package may be used through the last day of

the month and year as indicated on the original manufacturer's packaging.

16.9. The AGELESS packet contained in this package absorbs oxygen and generates heat on removal. Do not open and handle it with care.

16.10. Dispose of the AGELESS packet with the blister tray.

16.11. Do not dispose the AGELESS packet with wastes containing volatile or flammable materials.

16.12. For the Triple blood bag sets, Codes **BB*TCD456A2** and **BB*TCD506A2** are supplied 30/case.

16.13. For the Quadruple blood bag sets, Codes **BB*QCD456A2** and **BB*QCD506A2** are supplied 24/case.

MANUFACTURED BY:

TERUMO CORPORATION

44-1, 2-CHOME, HATAGAYA, SHIBUYA-KU,

TOKYO 151-0072, JAPAN

MADE IN JAPAN

© TERUMO CORPORATION Mar. 2021

All brand names are trademarks or registered trademarks of TERUMO CORPORATION and their respective owners.

PROCEDURE FOR USE OF DonorCare™ Needle Guard

This device is for use by trained individuals.

Intended Use

The DonorCare Needle Guard is incorporated onto the donor tubing to shield the needle immediately after withdrawal from the donor.

Single Use Only.

Preparation

1. Move the DonorCare on the tubing ensuring that it slides easily and the arrow is pointing toward the needle hub.

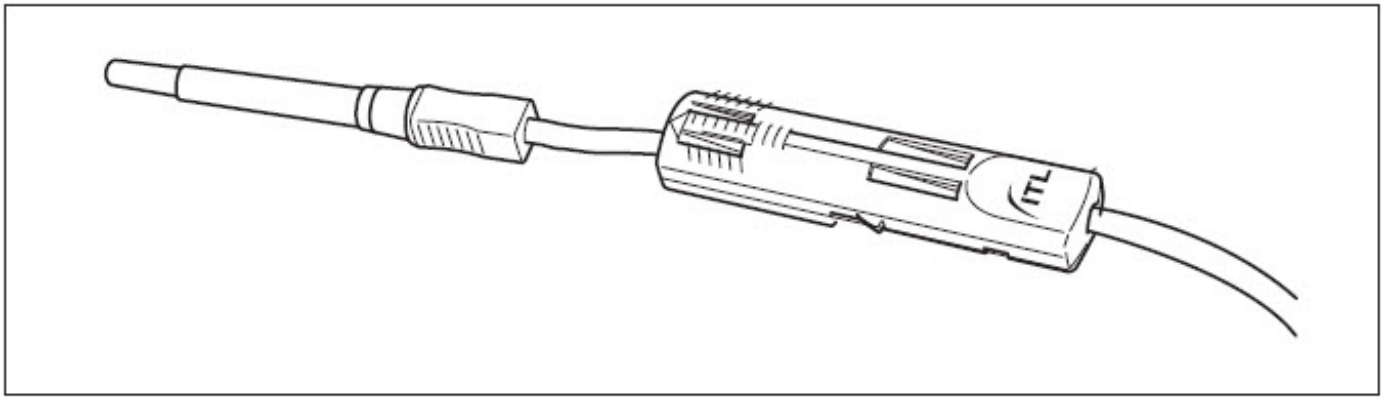

2. Ensure that the three lock points on the DonorCare are locked closed.

Whole Blood Collection

3. Perform the phlebotomy as per your institution's standard operating procedures.
4. Slide the DonorCare over the needle hub so that it covers approximately one half to two thirds of the needle hub.
5. Stabilize the DonorCare to the arm by placing a piece of tape over the front end so that the tape does not extend over the front of the DonorCare.

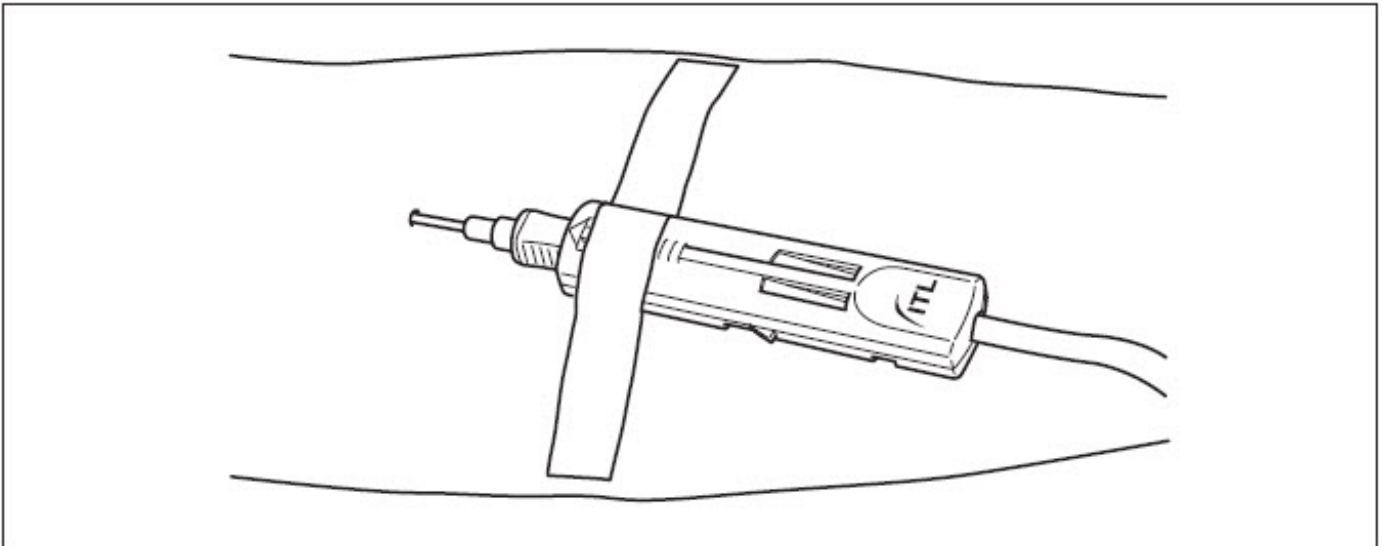

Withdrawal of Needle

Important	The DonorCare must be held stationary while the needle is withdrawn into it.
Caution	The needle must be fully shielded by DonorCare to prevent accidental injury.

6. Hold gauze over the venipuncture site with finger tips without exerting pressure. Hold the sides of the DonorCare near the front with the index finger and thumb of the same hand.

7. With the other hand, hold the donor tubing close behind the DonorCare.

Note: A hemostat may be placed on the tubing behind the DonorCare when the blood collection is complete. This will help to prevent blood drops from forming.

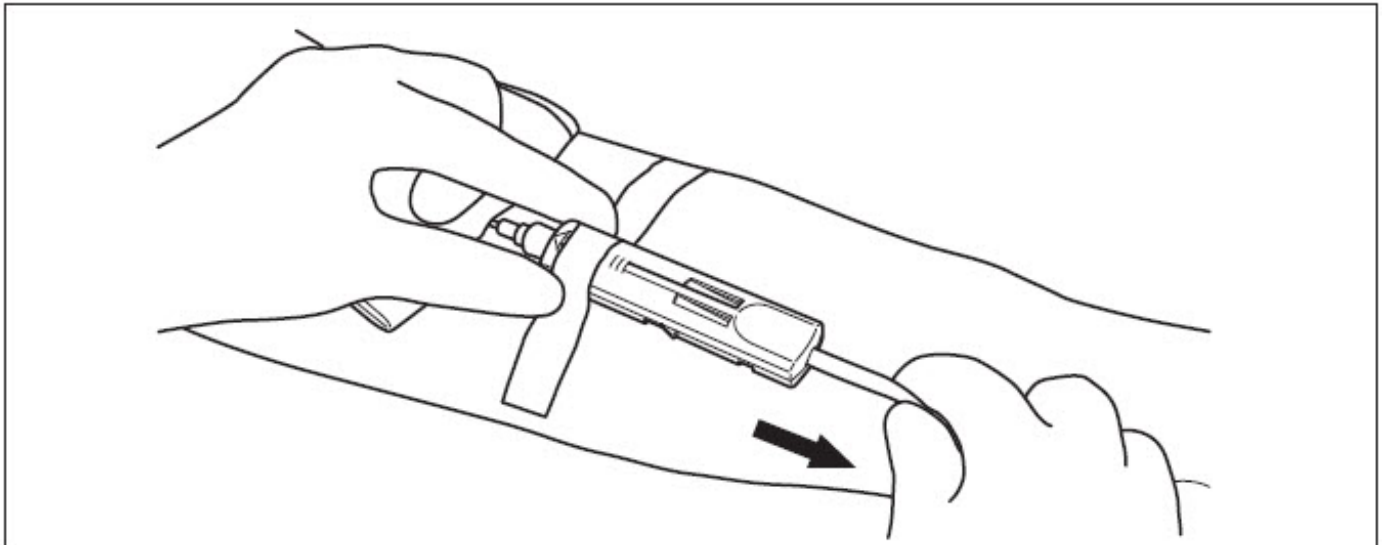

8. Pull tubing smoothly and swiftly with one motion until the needle is locked in place inside the DonorCare.

9. Confirm that the needle is locked by:

- a. Listening for two 'clicks' as the needle is drawn into DonorCare.
- b. If the clicks are not heard as the needle is drawn into the DonorCare, continue to pull firmly on the tubing to assure needle is fully withdrawn into DonorCare.

10. Visually check that the needle is fully shielded by DonorCare before removing from the donor's arm.

11. Remove the tape from the DonorCare and arm.

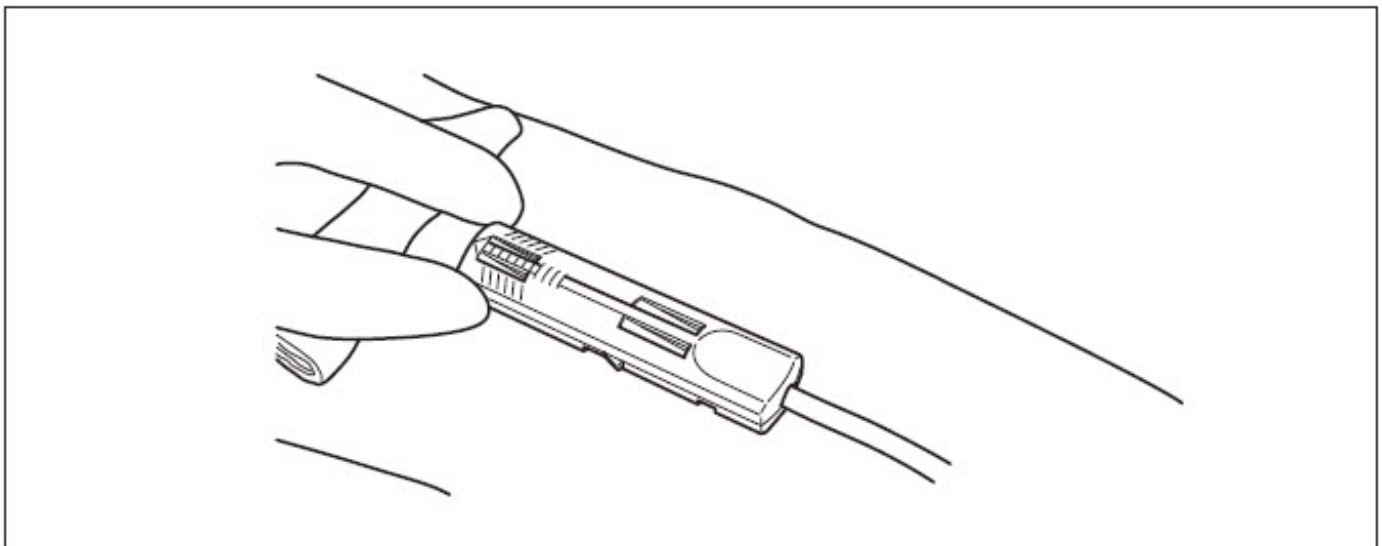

12. Apply pressure to the gauze covering the venipuncture site.

Warning Do not place fingers at the opening of DonorCare after removal from the donor's arm.

Difficult Phlebotomy (Examples may include: Slow blood flow, deep or fine vein, steep angle)

It may be necessary to delay placing the DonorCare over the needle hub until the end of the blood collection. In such situations:

Leave the DonorCare on the tubing behind the needle hub. At the end of the blood collection carefully remove the tape from the needle hub and slide the DonorCare over the hub so that it covers approximately one half to two thirds of the needle hub.

Withdraw the needle into the DonorCare as stated in steps 6. through 12. above.

Rx ONLY

DonorCare is manufactured by ITL Corporation, Melbourne, Australia.

TERUMO CORPORATION

44-1, 2-CHOME, HATAGAYA, SHIBUYA-KU,
TOKYO 151-0072, JAPAN

© TERUMO CORPORATION Mar. 2021

PRINCIPAL DISPLAY PANEL - 70 mL Bag Blister Pack Case Label

TERUFLEX™
BLOOD BAG SYSTEM with
Diversion Blood Sampling Arm™

TERUMO

ANTICOAGULANT CITRATE PHOSPHATE
DEXTROSE ADENINE SOLUTION (CPDA-1) USP
FOR COLLECTION OF 500mL OF BLOOD

Each unit consists of a primary bag containing 70 mL of solution with 209 mg Citric Acid (anhydrous) USP, 1.84 g Sodium Citrate (dihydrate) USP, 155 mg Monobasic Sodium Phosphate (monohydrate) USP, 2.23 g Dextrose (monohydrate) USP, 19.3 mg Adenine USP.

STERILE, NON-PYROGENIC
FLUID PATH.
DO NOT USE UNLESS
ANTICOAGULANT IS CLEAR.

NDC:53877-109-06

CODE

LOT NO.

EXPIRY

DONOR NEEDLE 16G × 1½"(1.60 × 38 mm)

UNITS

Rx ONLY

RECOMMENDED STORAGE: Room Temperature (15-30°C/59-86°F).
Avoid excessive heat. Protect from freezing.

After opening, unused bags may be stored at room temperature for 96 hours, or they may be stored for 30 days in the blister package after returning the cover film to original position and sealing with tape to prevent possible loss of moisture. See Instructions For Blood Collection.

Manufactured by : TERUMO CORPORATION Tokyo, Japan

All brand names are trademarks or registered trademarks owned by TERUMO CORPORATION, its affiliates, or unrelated third parties.

Rev. 2024-07
SC-2-H6-A2 ①

TERUFLEX™

TERUMO

**BLOOD BAG SYSTEM with
Diversion Blood Sampling Arm™**

**ANTICOAGULANT CITRATE PHOSPHATE
DEXTROSE ADENINE SOLUTION (CPDA-1) USP
FOR COLLECTION OF 500mL OF BLOOD**

Each unit consists of a primary bag containing 70 mL of solution with 209 mg Citric Acid (anhydrous) USP, 1.84 g Sodium Citrate (dihydrate) USP, 155 mg Monobasic Sodium Phosphate (monohydrate) USP, 2.23 g Dextrose (monohydrate) USP, 19.3 mg Adenine USP.

STERILE, NON-PYROGENIC
FLUID PATH.
DO NOT USE UNLESS
ANTICOAGULANT IS CLEAR.



NDC:53877-109-06

(01)00353877109063

CODE

LOT NO.

EXPIRY

UNITS

DONOR NEEDLE **16G×1½" (1.60×38mm)**

Rx ONLY

RECOMMENDED STORAGE: Room Temperature (15-30°C/59-86°F).
Avoid excessive heat. Protect from freezing.

After opening, unused bags may be stored at room temperature for 96 hours, or they may be stored for 30 days in the blister package after returning the cover film to original position and sealing with tape to prevent possible loss of moisture. See Instructions For Blood Collection.

Manufactured by : **TERUMO CORPORATION** Tokyo, Japan

All brand names are trademarks or registered trademarks owned by TERUMO CORPORATION, its affiliates, or unrelated third parties.

Rev. 2024-07

SC-2-H6-A2 ①

**TERUFLEX BLOOD WITH DIVERSION BLOOD SAMPLING ARM 70 ML
CPDA-1**

anhydrous citric acid, trisodium citrate dihydrate, sodium phosphate, monobasic, monohydrate, dextrose monohydrate, and adenine solution

Product Information

Product Type	HUMAN PRESCRIPTION DRUG	Item Code (Source)	NDC:53877-109
Route of Administration	INTRAVENOUS		

Active Ingredient/Active Moiety		
Ingredient Name	Basis of Strength	Strength
Anhydrous Citric Acid (UNII: XF417D3PSL) (Anhydrous Citric Acid - UNII:XF417D3PSL)	Anhydrous Citric Acid	2.99 g in 1000 mL
Trisodium Citrate Dihydrate (UNII: B22547B95K) (Anhydrous Citric Acid - UNII:XF417D3PSL)	Anhydrous Citric Acid	26.3 g in 1000 mL
Sodium Phosphate, Monobasic, Monohydrate (UNII: 593YOG76RN) (PHOSPHATE ION - UNII:NK08V8K8HR)	Sodium Phosphate, Monobasic, Monohydrate	2.22 g in 1000 mL
Dextrose Monohydrate (UNII: LX22YL083G) (Anhydrous Dextrose - UNII:5SLOG7R0OK)	Dextrose Monohydrate	31.9 g in 1000 mL
Adenine (UNII: JAC85A2161) (Adenine - UNII:JAC85A2161)	Adenine	0.275 g in 1000 mL

Inactive Ingredients	
Ingredient Name	Strength
Water (UNII: 059QF0K00R)	

Packaging				
#	Item Code	Package Description	Marketing Start Date	Marketing End Date
1	NDC:53877-109-06	6 in 1 CASE		
1	NDC:53877-109-01	4 in 1 BLISTER PACK		
1	NDC:53877-109-02	70 mL in 1 BAG; Type 9: Other Type of Part 3 Combination Product (e.g., Drug/Device/Biological Product)		

Marketing Information			
Marketing Category	Application Number or Monograph Citation	Marketing Start Date	Marketing End Date
NDA	BN820528	05/22/2012	

Labeler - Terumo Corporation (690543319)

Establishment			
Name	Address	ID/FEI	Business Operations
Terumo Corp. - Fujinomiya Factory		695214015	MANUFACTURE(53877-109) , ANALYSIS(53877-109) , STERILIZE(53877-109) , LABEL(53877-109)

Revised: 10/2024

Terumo Corporation