

# **CAMCEVI- leuprolide injection, emulsion**

## **Foresee Pharmaceuticals Co., Ltd.**

-----

### **HIGHLIGHTS OF PRESCRIBING INFORMATION**

**These highlights do not include all the information needed to use CAMCEVI™ safely and effectively. See full prescribing information for CAMCEVI.**

### **CAMCEVI (leuprolide) injectable emulsion, for subcutaneous use**

**Initial U.S. Approval: 2021**

#### **INDICATIONS AND USAGE**

CAMCEVI is a gonadotropin-releasing hormone (GnRH) agonist indicated for the treatment of adult patients with advanced prostate cancer. (1)

#### **DOSAGE AND ADMINISTRATION**

- See Full Prescribing Information for instructions on the preparation and administration of the injectable emulsion in a pre-filled syringe. (2)
- Recommended Dosage: 42 mg subcutaneously every 6 months. (2)

#### **DOSAGE FORMS AND STRENGTHS**

- Injectable emulsion: 42 mg (3)

#### **CONTRAINDICATIONS**

- Hypersensitivity to GnRH, GnRH agonist analogs, or any of the components of CAMCEVI. (4)

#### **WARNINGS AND PRECAUTIONS**

- Tumor Flare: Transient worsening of bone pain, uretral obstruction, spinal cord compression, or the occurrence of additional signs and symptoms of prostate cancer may develop during the first few weeks of treatment. Monitor patients closely and manage symptoms. (5.1)
- Hyperglycemia and Diabetes: Hyperglycemia and an increased risk of developing diabetes have been reported in men receiving GnRH agonists. Monitor blood glucose level and manage according to current clinical practice. (5.2)
- Cardiovascular Diseases: Increased risk of myocardial infarction, sudden cardiac death, and stroke has been reported in men receiving GnRH agonists. Monitor for cardiovascular disease and manage according to current clinical practice. (5.3)
- QT/QTc Prolongation: Androgen deprivation therapy may prolong the QT interval. Consider periodic monitoring of electrocardiograms and electrolytes. (5.4)
- Convulsions: Manage convulsions according to the current clinical practice. (5.5)
- Embryo-Fetal Toxicity: CAMCEVI may cause fetal harm. (5.7, 8.1)

#### **ADVERSE REACTIONS**

The most common ( $\geq 10\%$ ) adverse reactions were hot flush, hypertension, injection site reactions, upper respiratory tract infections, musculoskeletal pain, fatigue, and pain in extremity. (6.1)

**To report SUSPECTED ADVERSE REACTIONS, contact Foresee Pharmaceuticals at 1-866-941-7875 or FDA at 1-800-FDA-1088 or [www.fda.gov/medwatch](http://www.fda.gov/medwatch)**

#### **USE IN SPECIFIC POPULATIONS**

- Females and males of reproductive potential: CAMCEVI may impair fertility. (8.3)
- Safety and effectiveness in pediatric patients have not been established. (8.4)

**See 17 for PATIENT COUNSELING INFORMATION.**

**Revised: 6/2021**

---

**FULL PRESCRIBING INFORMATION: CONTENTS\***

## **1 INDICATIONS AND USAGE**

## **2 DOSAGE AND ADMINISTRATION**

2.1 Recommended Dosage

2.2 Preparation and Administration

## **3 DOSAGE FORMS AND STRENGTHS**

## **4 CONTRAINDICATIONS**

## **5 WARNINGS AND PRECAUTIONS**

5.1 Tumor Flare

5.2 Hyperglycemia and Diabetes

5.3 Cardiovascular Diseases

5.4 QT/QTc Prolongation

5.5 Convulsions

5.6 Laboratory Tests

5.7 Embryo-Fetal Toxicity

## **6 ADVERSE REACTIONS**

6.1 Clinical Trial Experience

6.2 Postmarketing Experience

## **8 USE IN SPECIFIC POPULATIONS**

8.1 Pregnancy

8.2 Lactation

8.3 Females and Males of Reproductive Potential

8.4 Pediatric Use

8.5 Geriatric Use

## **11 DESCRIPTION**

## **12 CLINICAL PHARMACOLOGY**

12.1 Mechanism of Action

12.2 Pharmacodynamics

12.3 Pharmacokinetics

## **13 NONCLINICAL TOXICOLOGY**

13.1 Carcinogenesis, Mutagenesis, Impairment of Fertility

## **14 CLINICAL STUDIES**

## **16 HOW SUPPLIED/STORAGE AND HANDLING**

## **17 PATIENT COUNSELING INFORMATION**

\* Sections or subsections omitted from the full prescribing information are not listed.

---

## **FULL PRESCRIBING INFORMATION**

### **1 INDICATIONS AND USAGE**

CAMCEVI is indicated for the treatment of adult patients with advanced prostate cancer.

### **2 DOSAGE AND ADMINISTRATION**

#### **2.1 Recommended Dosage**

CAMCEVI must be administered by a healthcare provider.

The recommended dose of CAMCEVI is 42 mg administered subcutaneously once every 6 months.

## 2.2 Preparation and Administration

### Syringe Assembly

1. Remove CAMCEVI kit from refrigerator. Open carton and remove blister.
2. Allow prefilled syringe to sit at room temperature for 30 minutes prior to subcutaneous injection.
3. Examine all contents of the package. Do not use if any component is damaged.
4. Check the expiration date on the syringe. Do not use if the expiration date has passed.
5. The use of gloves is recommended during syringe assembly and administration.
6. On a clean, dry surface, remove pre-filled syringe (A) and needle cartridge (B) from the blister carton. Visually inspect the contents prior to use.
7. Remove the gray cap from the syringe (A).
8. Twist the clear cap off the bottom of the needle cartridge (B).
9. Attach the needle (B) to the end of the syringe (A) by pushing and turning the needle until firmly connected to the syringe. Do not over twist the needle and strip the threading.

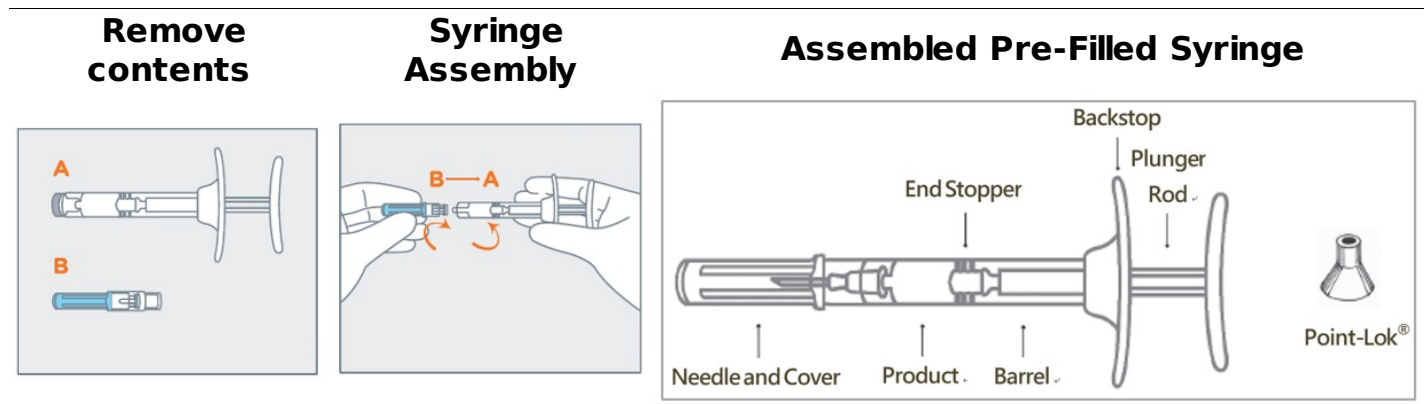

### Administration Procedure

1. Choose an injection site on the upper- or mid-abdominal area with sufficient soft or loose subcutaneous tissue that has not recently been used. Clean the injection site with an alcohol swab. Do **NOT** inject in areas with brawny or fibrous subcutaneous tissue or locations that can be rubbed or compressed (i.e., with a belt or clothing waistband). In addition, avoid applying heat directly to the site of CAMCEVI injection.
2. Pull the blue cover off the needle (B). Use standard sharps safety techniques to avoid needle sticks.
3. Use standard aseptic technique when performing the injection. Grab and bunch the skin around the injection site with one hand. Insert the needle at a 90° angle to the skin surface, and then release the bunched skin.
4. Inject the full contents of the syringe with a slow and steady push on the plunger, and then withdraw the needle at the same 90° angle used for insertion.

**Prepare the Injection Site**

**Administer Treatment**



### Needle Protection

1. Do not remove the needle from the syringe. Use the enclosed Point-Lok<sup>®</sup> device to prevent needle sticks.
2. Retrieve the Point-Lok<sup>®</sup> needle protection device from the Camcevi kit and place it on a secured, flat surface with its largest surface base touching the surface as shown in the diagram below.
3. Immediately after use of the needle, gently insert the exposed needle into the Point-Lok<sup>®</sup> device opening at the top of the Point-Lok<sup>®</sup> device. (see Figure 1 below)
4. Push the needle into the top opening until it is fully inserted into the Point-Lok<sup>®</sup> device. This action will seal the needle tip and lock the needle firmly into the Point-Lok<sup>®</sup> device. (see Figure 2 below)

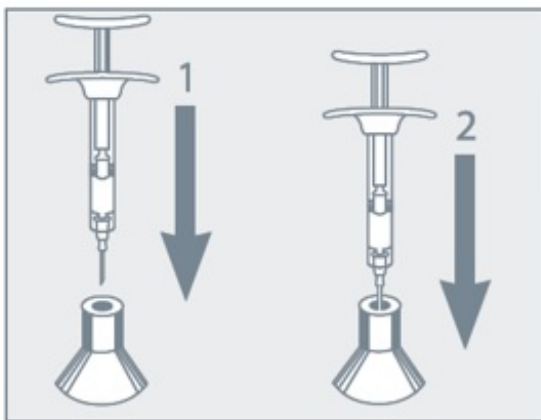

5. After use, place the used syringe with needle protected in a suitable sharps container. Dispose of contaminated product in a safe manner according to Centers for Disease Control and Prevention, USA and Federal/State/Local regulations (EPA, OSHA) and health care facility guidelines or local equivalent.

## **3 DOSAGE FORMS AND STRENGTHS**

Injectable emulsion: 42 mg leuprolide (equivalent to approximately 48 mg leuprolide mesylate) as a sterile, off-white to pale yellow, viscous, and opalescent emulsion in a single-dose, pre-filled syringe for subcutaneous injection.

## **4 CONTRAINDICATIONS**

CAMCEVI is contraindicated in patients known to be hypersensitive to GnRH, GnRH agonist analogs, or any of the excipients in CAMCEVI. Anaphylactic reactions to GnRH agonist analogs have been reported in the medical literature.

## **5 WARNINGS AND PRECAUTIONS**

### **5.1 Tumor Flare**

CAMCEVI, like other GnRH agonists, causes a transient increase in serum levels of testosterone during the first week of treatment, declining thereafter to baseline levels or below by the end of the second week of treatment. Transient worsening of symptoms, or the occurrence of additional signs and symptoms of prostate cancer, may develop during the first few weeks of CAMCEVI treatment. Patients treated with CAMCEVI may experience a temporary increase in bone pain, which can be managed symptomatically.

As with other GnRH agonists, cases of ureteral obstruction and spinal cord compression have been observed, which may contribute to paralysis with or without fatal complications.

Patients with metastatic vertebral lesions and/or with urinary tract obstruction should be closely observed during the first few weeks of therapy.

### **5.2 Hyperglycemia and Diabetes**

Hyperglycemia and an increased risk of developing diabetes have been reported in men receiving GnRH agonists. Hyperglycemia may represent the development of diabetes mellitus or worsening of glycemic control in patients with diabetes. Monitor blood glucose and/or glycosylated hemoglobin (HbA1c) periodically in patients receiving a GnRH agonist and manage with current practice for treatment of hyperglycemia or diabetes.

### **5.3 Cardiovascular Diseases**

Increased risk of developing myocardial infarction, sudden cardiac death, and stroke has been reported in association with use of GnRH agonists in men. The risk appears low based on the reported odds ratios, and should be evaluated carefully along with cardiovascular risk factors when determining a treatment for patients with prostate cancer. Patients receiving a GnRH agonist should be monitored for symptoms and signs suggestive of development of cardiovascular disease and be managed according to current clinical practice.

### **5.4 QT/QTc Prolongation**

Androgen deprivation therapy may prolong the QT/QTc interval. Providers should consider whether the benefits of androgen deprivation therapy outweigh the potential risks in patients with congenital long QT syndrome, congestive heart failure, frequent electrolyte abnormalities, and in patients taking drugs known to prolong the QT interval. Electrolyte abnormalities should be corrected. Consider periodic monitoring of electrocardiograms and electrolytes.

### **5.5 Convulsions**

Convulsions have been reported in patients receiving GnRH agonists, like CAMCEVI [see *Adverse Reactions (6.2)*]. Manage patients receiving a GnRH agonist who experience convulsions according to current clinical practice.

### **5.6 Laboratory Tests**

Monitor serum levels of testosterone following injection of CAMCEVI. In the majority of patients treated with CAMCEVI, testosterone levels increased above baseline during the first week, and then declined thereafter to castration levels (<50 ng/dL) within 4 weeks [see *Clinical Studies (14) and Adverse Reactions (6)*].

## 5.7 Embryo-Fetal Toxicity

Based on findings in animal studies and mechanism of action, CAMCEVI can cause fetal harm when administered to a pregnant woman. In animal developmental and reproductive toxicology studies, administration of a monthly formulation of leuprolide on day 6 of pregnancy (sustained exposure was expected throughout the period of organogenesis) caused adverse embryo-fetal toxicity in animals at doses less than the human dose based on body surface area using an estimated daily dose. Advise pregnant patients and females of reproductive potential of the potential risk to the fetus [see *Use in Specific Population (8.1), Clinical Pharmacology (12.1)*].

## 6 ADVERSE REACTIONS

The following adverse reactions are discussed in greater detail in other sections of the labeling:

- Tumor Flare [see *Warnings and Precautions (5.1)*]
- Hyperglycemia and Diabetes [see *Warnings and Precautions (5.2)*]
- Cardiovascular Diseases [see *Warnings and Precautions (5.3)*]
- QT/QTc Prolongation [see *Warnings and Precautions (5.4)*]
- Convulsions [see *Warnings and Precautions (5.5)*]

### 6.1 Clinical Trial Experience

Because clinical trials are conducted under widely varying conditions, adverse reaction rates observed in the clinical trials of a drug cannot be directly compared to rates in the clinical trials of another drug and may not reflect the rates observed in practice. In an open-label, non-comparative clinical trial (FP01C-13-001), patients with advanced prostate cancer received CAMCEVI administered subcutaneously at a dose of 42 mg on Day 0 and Day 168. Of 137 patients enrolled, 93% received both doses of CAMCEVI.

Serious adverse reactions occurred in 15% of patients who received CAMCEVI, including 1% of patients who experienced subdural hematoma. Fatal adverse reactions occurred in 2% of patients, including cerebrovascular accident (0.7%) and pulmonary embolism (0.7%).

The most common adverse reactions ( $\geq 10\%$ ) occurring during a median follow-up duration of 336 days were hot flush, hypertension, injection site reactions, upper respiratory tract infections, musculoskeletal pain, fatigue, and pain in extremity.

Table 1 summarizes the adverse reactions in FP01C-13-001.

**Table 1. Adverse Reactions Occurring in  $\geq 5\%$  of Patients - FP01C-13-001**

---

| <u>Adverse Reaction</u> | <u>N = 137</u>           |
|-------------------------|--------------------------|
|                         | <u>All</u> <u>Grade</u>  |
|                         | <u>Grades</u> <u>3-4</u> |

|  | <b>(%)</b> | <b>(%)</b> |
|--|------------|------------|
| Vascular disorders                                   |            |            |
| Hot flush*   | 50         | 0          |
| Hypertension†  | 15         | 0          |
| General disorders and administration site conditions |            |            |
| Injection site reactions‡                            | 11         | 0          |
| Fatigue§   | 10         | 0          |
| Infections and infestations                          |            |            |
| Upper respiratory tract infection¶                   | 11         | 0          |
| Musculoskeletal and connective tissue disorders      |            |            |
| Musculoskeletal pain#                                | 11         | 0          |
| Pain in extremity                                    | 10         | 0          |
| Arthralgia   | 7          | 0          |
| Renal and urinary disorders                          |            |            |
| Micturition urgency <sup>p</sup>                     | 6          | 0          |
| Nocturia   | 6          | 0          |
| Nervous system disorders                             |            |            |
| Dizziness <sup>β</sup>                               | 5          | 0.7        |

\* includes hot flush and flushing

† includes hypertension, essential hypertension, and blood pressure increased

‡ includes injection site pain, injection site erythema, injection site hemorrhage, injection site nodule, injection site paraesthesia, injection site pruritus, and injection site warmth

§ includes fatigue and asthenia

¶ includes upper respiratory tract infection, sinusitis, and nasopharyngitis

# includes musculoskeletal pain, back pain, and bone pain

<sup>p</sup> includes micturition urgency and dysuria

<sup>β</sup> includes dizziness, dizziness postural, vertigo, and vertigo positional.

## 6.2 Postmarketing Experience

The following adverse reactions have been identified during post approval use of leuprolide. Because these reactions are reported voluntarily from a population of uncertain size, it is not always possible to reliably estimate their frequency or establish a causal relationship to drug exposure.

During postmarketing surveillance, which includes other dosage forms and other patient populations, the following adverse reactions were reported.

*Allergic Conditions:* anaphylactoid or asthmatic process, rash, urticaria, and photosensitivity reactions

*Cardiovascular System:* hypotension, myocardial infarction, pulmonary embolism

*Central/Peripheral Nervous System:* convulsion, peripheral neuropathy, spinal fracture/paralysis

*Endocrine System:* pituitary apoplexy, diabetes

*Hepato-biliary disorder:* drug-induced liver injury

*Hematologic:* white blood cells

*Psychiatric:* mood swings, including depression, suicidal ideation and attempt

*Respiratory, thoracic and mediastinal disorder:* interstitial lung disease

*Musculoskeletal System:* decreased bone density, tenosynovitis-like symptoms, fibromyalgia

*Skin and Subcutaneous:* injection site reactions

*Urogenital System:* prostate pain

## **8 USE IN SPECIFIC POPULATIONS**

### **8.1 Pregnancy**

#### Risk Summary

Based on findings in animal studies and mechanism of action, CAMCEVI can cause fetal harm when administered to a pregnant woman [see *Clinical Pharmacology (12.1)*]. There are no available data in pregnant women to inform the drug-associated risk. In animal developmental and reproductive toxicology studies, administration of a monthly formulation of leuprolide on day 6 of pregnancy (sustained exposure was expected throughout the period of organogenesis) caused adverse embryo-fetal toxicity in animals at doses less than the human dose based on body surface area using an estimated daily dose (see *data*). Advise pregnant patients and females of reproductive potential of the potential risk to the fetus.

#### Data

##### *Animal Data*

Major fetal malformations were observed in developmental and reproductive toxicology studies in rabbits after a single administration of a monthly formulation of leuprolide administered on day 6 of pregnancy at test dosages of 0.00024, 0.0024, and 0.024 mg/kg (approximately 1/1500 to 1/15 the human dose based on body surface area using an estimated daily dose in animals and humans). Since a depot formulation was utilized in the study, a sustained exposure to leuprolide was expected throughout the period of organogenesis and to the end of gestation. Similar studies in rats did not demonstrate an increase in fetal malformations, however, there was increased fetal mortality and decreased fetal weights with the two higher doses of the monthly formulation of leuprolide in rabbits and with the highest dose in rats.

### **8.2 Lactation**

#### Risk Summary

The safety and efficacy of CAMCEVI have not been established in females. There is no information regarding the presence of leuprolide in human milk, the effects on the breastfed child, or the effects on milk production. Because many drugs are excreted in human milk and because of the potential for serious adverse reactions in a breastfed child, a decision should be made to discontinue breastfeeding or discontinue the drug, taking into account the importance of the drug to the mother.

### **8.3 Females and Males of Reproductive Potential**

#### Infertility



## Males

Based on findings in animals and mechanism of action, CAMCEVI may impair fertility in males of reproductive potential [see *Clinical Pharmacology (12.1)*, *Nonclinical Toxicology (13.1)*].

### 8.4 Pediatric Use

The safety and efficacy of CAMCEVI in pediatric patients have not been established.

### 8.5 Geriatric Use

Of the 137 patients who received CAMCEVI in the FP01C-13-001 study, 74% were 65 years of age or older, while 37% were 75 years of age or older. No overall differences in safety or effectiveness were observed between these patients and younger patients.

## 11 DESCRIPTION

CAMCEVI is a sterile formulation of leuprolide mesylate for subcutaneous injection. CAMCEVI is designed to deliver approximately 42 mg of leuprolide over 6 months.

Leuprolide mesylate is a synthetic nonapeptide analog of naturally occurring GnRH and is a GnRH agonist. The analog possesses greater potency than the natural hormone. The chemical name is 5-oxo-L-prolyl-L-histidyl-L-tryptophyl-L-seryl-L-tyrosyl-D-leucyl-L-leucyl-L-arginyl-N-ethyl-L-prolinamide mesylate (salt) with the following structural formula. The pH of 50 mg/mL solution of leuprolide mesylate in water is approximately 5.7.

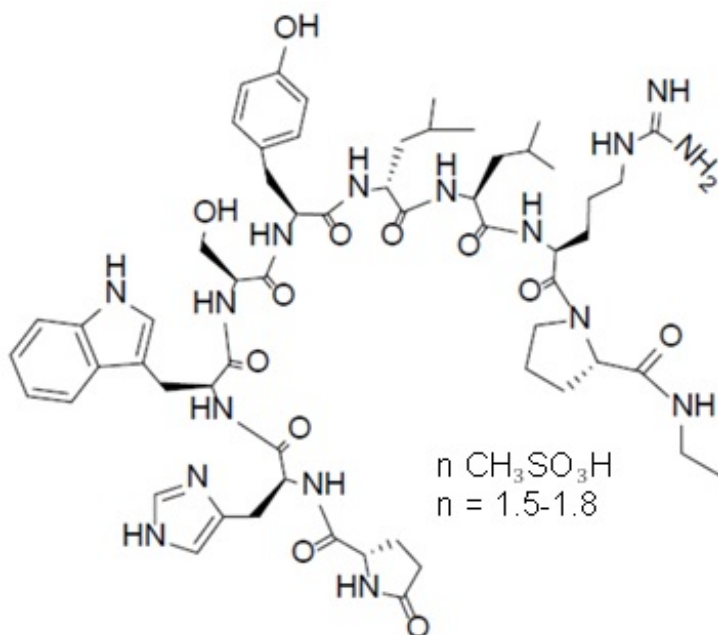

CAMCEVI is supplied as a kit with a pre-filled, single-dose, sterile syringe for subcutaneous injection. Each pre-filled syringe delivers 42 mg leuprolide (equivalent to approximately 48 mg leuprolide mesylate), poly(D, L-lactide) (184 mg) polymer and N-methyl-2-pyrrolidone (136 mg).

## 12 CLINICAL PHARMACOLOGY

## 12.1 Mechanism of Action

Leuprolide, a GnRH agonist, acts as an inhibitor of gonadotropin secretion. Animal and human studies indicate that following an initial stimulation of gonadotropins, chronic administration of leuprolide results in suppression of ovarian and testicular steroidogenesis. This effect is reversible upon discontinuation of drug therapy.

In humans, subcutaneous administration of single daily doses of leuprolide result in an initial increase in circulating levels of LH and FSH, leading to a transient increase in levels of the gonadal steroids (testosterone and dihydrotestosterone in males). However, continuous daily administration of leuprolide results in decreased levels of LH and FSH. In males, testosterone is reduced to below castration levels. These decreases generally occur within 2 to 4 weeks after initiation of treatment, and castration levels of testosterone in prostatic cancer patients have been demonstrated for periods of up to 5 years.

## 12.2 Pharmacodynamics

Mean serum testosterone concentrations transiently increased, then fell to below castrate threshold levels ( $\leq 50$  ng/dL) within 3 weeks following administration of the dose of leuprolide, and generally remained below castrate thresholds levels throughout treatment.

## 12.3 Pharmacokinetics

Leuprolide concentration is variable, exhibiting an initial rapid increase followed by a rapid decline over the first 3 days before reaching steady concentrations for the duration of the dosing interval. The mean serum leuprolide  $C_{max}$  was 94.5 and 99 ng/mL following the first and second doses of CAMCEVI, respectively. The mean serum concentration was maintained at 0.497–2.57 and 0.507–2.39 ng/ml after Day 3 post the first and second doses, respectively. The mean  $AUC_{0-6\text{ mon}}$  was 224 and 268 day.ng/mL following the first and second doses of CAMCEVI, respectively.

### Absorption

The median  $T_{max}$  of leuprolide was 3.2 and 2.1 hours following the first and second doses of CAMCEVI, respectively.

### Distribution

The mean steady-state volume of distribution of leuprolide was 27 L following an intravenous bolus in healthy male volunteers. Protein binding of leuprolide ranged from 43% to 49% in vitro.

### Elimination

The mean systemic clearance was 7.6 L/h and terminal elimination half-life of approximately 3 hours following an intravenous bolus of leuprolide in healthy male volunteers.

### *Metabolism*

Administration of radiolabeled leuprolide was metabolized to smaller inactive peptides which may then be further catabolized.

## *Excretion*

Excretion of leuprolide has not been evaluated with CAMCEVI.

## Specific Populations

No clinically significant differences in the systemic exposure of leuprolide were observed based on age (51 to 88 years), race/ethnicity (White, Black, Asian), or body weight (54 to 134 kg). The effect of renal or hepatic impairment on the pharmacokinetics of leuprolide has not been evaluated.

## **13 NONCLINICAL TOXICOLOGY**

### **13.1 Carcinogenesis, Mutagenesis, Impairment of Fertility**

Two-year carcinogenicity studies were conducted with leuprolide in rats and mice. In rats, a dose-related increase of benign pituitary hyperplasia and benign pituitary adenomas was noted at 24 months when the drug was administered subcutaneously at high daily doses (0.6 to 4 mg/kg). There was a significant but not dose-related increase of pancreatic islet-cell adenomas in females and of testicular interstitial cell adenomas in males (highest incidence in the low dose group). In mice, no pituitary abnormalities were observed at a dose as high as 60 mg/kg for 2 years. Patients have been treated with leuprolide for up to 3 years with doses as high as 10 mg/day and for 2 years with doses as high as 20 mg/day without demonstrable pituitary abnormalities.

Mutagenicity studies have been performed with leuprolide using bacterial and mammalian systems. These studies provided no evidence of mutagenic potential.

Leuprolide may reduce male and female fertility. Administration of leuprolide to male and female rats at doses of 0.024, 0.24, and 2.4 mg/kg as monthly depot formulation for up to 3 months (approximately as low as 1/30 of the human dose based on body surface area using an estimated daily dose in animals and humans) caused atrophy of the reproductive organs, and suppression of reproductive function. These changes were reversible upon cessation of treatment.

## **14 CLINICAL STUDIES**

The efficacy of CAMCEVI was evaluated in an open label, single arm, multinational study FP01C-13-001 (NCT02234115) in patients with advanced prostate carcinoma who have a baseline morning serum testosterone level >150 ng/dL and Eastern Cooperative Oncology Group performance status  $\leq$  2. CAMCEVI was administered subcutaneously at a dose of 42 mg initially on Day 0 and on Week 24.

The population (n = 137) had a median age of 71 years (range 51 to 88) and was 90% White, 6% Black, and 4% Asian. Disease stage was distributed as follows: 23% metastatic (M1), 27% locally advanced (T3/4 NX M0 or any T N1 M0), 26% localized (T1 or T2 N0 M0), and 24% not classifiable. The median testosterone concentration at baseline was 440 ng/dL.

The major efficacy outcome measure was medical castration rate, defined as achieving and maintaining serum testosterone suppression to  $\leq$  50 ng/dL by Week 4 through

Week 48 of treatment. Following the first injection of CAMCEVI, serum testosterone levels were suppressed to  $\leq 50$  ng/dL by Week 4 (+/-7 days) in 98.5% of the patients; and from Week 4 through Week 48 in 97.0% of patients (95% CI: 92.2-98.9) estimated using the Kaplan-Meier method. The time course of percent change from baseline in testosterone suppression are shown in Figure 1. The percentage of patients with testosterone suppression to  $\leq 20$  ng/dL was 69.3% on Day 28.

**Figure 1 CAMCEVI Mean (95% CI) Percentage Change from Baseline in Serum Testosterone Concentration Over Time (N =137)**

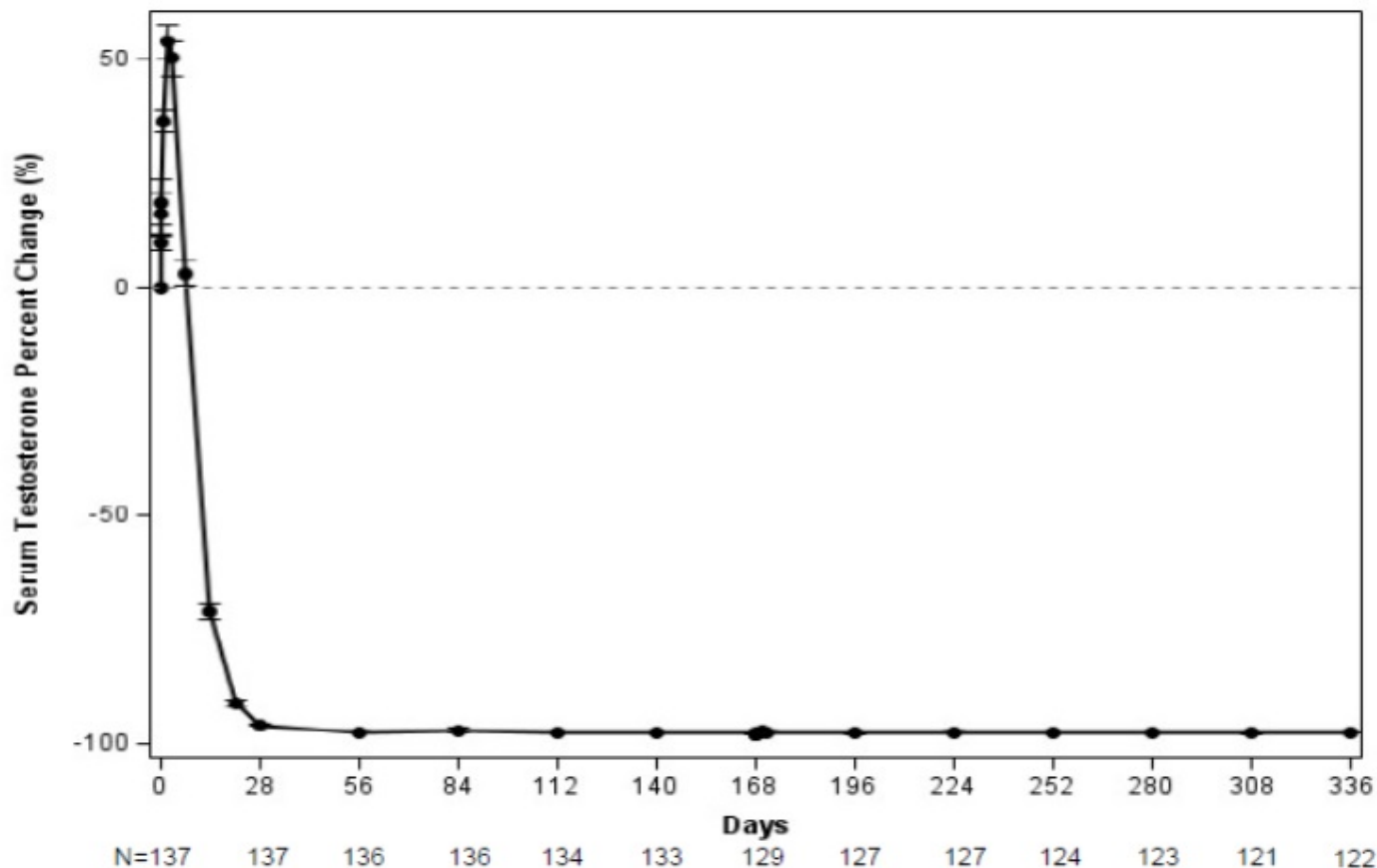

In the clinical trial, PSA levels were monitored and were lowered on average by 51% after 4 weeks after administration of CAMCEVI, 83% after 3 months and remained suppressed throughout the 48 weeks of treatment. These PSA results should be interpreted with caution because of the heterogeneity of the patient population studied. No evidence has shown that the rapidity of PSA decline correlates with clinical benefit.

## 16 HOW SUPPLIED/STORAGE AND HANDLING

CAMCEVI is a sterile, off-white to pale yellow, viscous and opalescent injectable emulsion supplied in a kit as a single-dose, pre-filled syringe. CAMCEVI is available as follows:

|   |              |
|---|--------------|
| Kit Contents  | NDC          |
| Injectable emulsion in a pre-filled syringe containing 42 mg leuprolide for subcutaneous injection, a sterile 18 gauge needle, a Point-Lok <sup>®</sup> needle protection device, and Instructions for Use. | 72851-042-01 |

Store CAMCEVI at 2°C–8°C (36°F–46°F). Protect CAMCEVI from light by storing in the original package until time of use. Do not freeze or shake.

The rubber used in syringe tip cap and plunger stopper is not made of natural rubber latex.

## **17 PATIENT COUNSELING INFORMATION**

### Hypersensitivity

- Inform patients that if they have experienced hypersensitivity with other GnRH agonist drugs like CAMCEVI, CAMCEVI is contraindicated [*see Contraindications (4)*].

### Tumor Flare

- Inform patients that CAMCEVI can cause tumor flare during the first weeks of treatment. Inform patients that the increase in testosterone can cause an increase in urinary symptoms or pain. Advise patients to contact their healthcare provider if urethral obstruction, spinal cord compression, paralysis, or new or worsened symptoms occur after beginning CAMCEVI treatment [*see Warnings and Precautions (5.1)*].

### Hyperglycemia and Diabetes

- Advise patients that there is an increased risk of hyperglycemia and diabetes with CAMCEVI therapy. Inform patients that periodic monitoring for hyperglycemia and diabetes is required when being treated with CAMCEVI [*see Warnings and Precautions (5.2)*].

### Cardiovascular Disease

- Inform patients that there is an increased risk of myocardial infarction, sudden cardiac death, and stroke with CAMCEVI treatment. Advise patients to immediately report signs and symptoms associated with these events to their healthcare provider for evaluation [*see Warnings and Precautions (5.3)*].

### QT/QTc Prolongation

- Inform patients that CAMCEVI can cause QT/QTc prolongation. Advise patients to immediately contact their healthcare provider in the event of syncope, presyncopal symptoms, or cardiac palpitations [*see Warnings and Precautions (5.4)*].
- .

### Convulsions

- Inform patients that there is an increased risk of convulsions with CAMCEVI treatment. Advise patients to immediately contact their healthcare provider if they experience convulsions [*see Warnings and Precautions (5.5)*].

### Injection Site Reactions

- Inform patients that injection site related adverse reactions may occur such as transient burning/stinging, pain, bruising, and redness. Advise patients to contact their healthcare provider if they experience rash or severe injection site reactions [*see Adverse Reactions (6.1)*].

### Urogenital Disorders

- Advise patients that CAMCEVI may cause impotence.

### Infertility

- Inform patients that CAMCEVI may cause infertility [see *Use In Specific Populations* (8.3)].

Manufactured for:

Foresee Pharmaceuticals Co., Ltd.

9F-2, No. 19-3, Sanchong Rd., Nangang Dist., Taipei City 115, Taiwan

By:

Fareva Pau 1

Avenue du Bearn, 64320 Idron, France

## Instructions for Use



42 mg single-dose prefilled syringe

**You must read these complete instructions before you administer CAMCEVI for the first time. CAMCEVI must be administered by a healthcare provider.**

### **What is CAMCEVI?**

CAMCEVI is a subcutaneous injection that provides long-acting gonadotropin releasing hormone (GnRH) agonist to patients. CAMCEVI contains a biodegradable polymer formulation dissolved in a biocompatible solvent that provides sustained release of leuprolide. CAMCEVI is supplied as a kit containing one sterile, pre-filled syringe for subcutaneous injection, one sterile 18-gauge needle, one Point-Lok® needle protection device, and Instructions for Use.

### **Dosage**

The recommended dosing is 1 subcutaneous injection (42 mg leuprolide) every 6 months.

#### **Read these critical instructions.**

*Do not substitute any of the components from the kit for administration.*

CAMCEVI is packaged in a blister in the kit. Check to make sure the kit contains:

- One sterile, single-dose prefilled syringe with plunger rod and backstop
- One sterile 18-gauge, 5/8-inch needle
- One Point-Lok® needle protection device
- Instructions for Use and Prescribing Information

### **Before you begin to**

## Begin to prepare CAMCEVI Injection

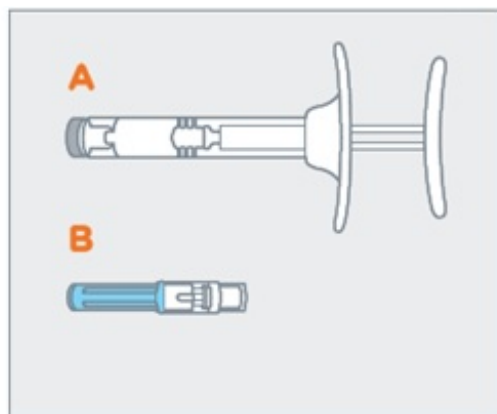

Point-Lok®

© Point-Lok is a registered trademark of Smiths Medical

## Bring CAMCEVI to room temperature

### STEP To bring CAMCEVI to room temperature:

- 1 Remove CAMCEVI kit from refrigerator. Open carton and remove blister.  
2 Allow prefilled syringe to sit at room temperature for 30 minutes prior to subcutaneous injection.

## Prepare the syringe

### STEP Follow these steps to prepare CAMCEVI for use:

- 1 Examine all contents of the package. Do not use if any component is damaged.
- 2 Check the expiration date on the syringe. Do not use if the expiration date has passed.
- 3 The use of gloves is recommended during syringe assembly and administration.  
On a clean, dry surface, remove pre-filled syringe (A) and needle cartridge (B) from the blister carton. Visually inspect the contents prior to use.

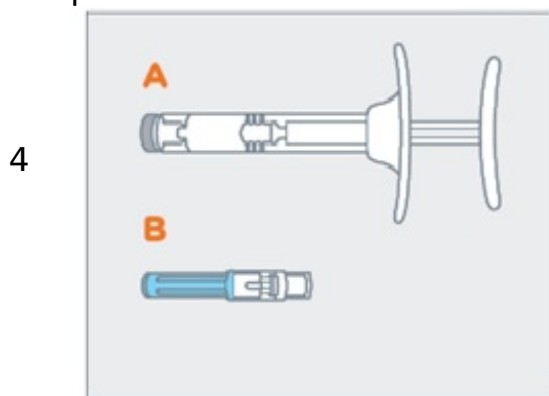

- 4  
5 Remove the gray cap from the syringe (A). Twist the clear cap off the bottom of the needle cartridge (B).  
Attach the needle (B) to the end of the syringe (A) by pushing and turning the needle until firmly connected to the syringe. **Do not** over twist the needle and strip the threading.

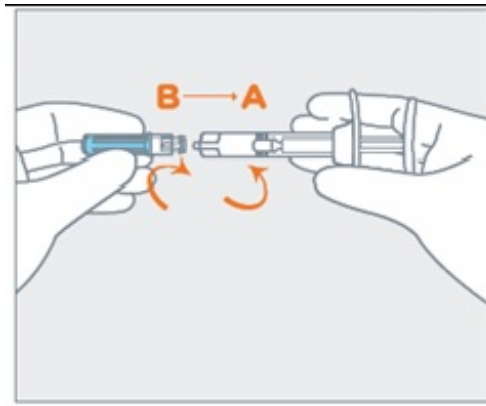

6

Assembled Pre-Filled Syringe

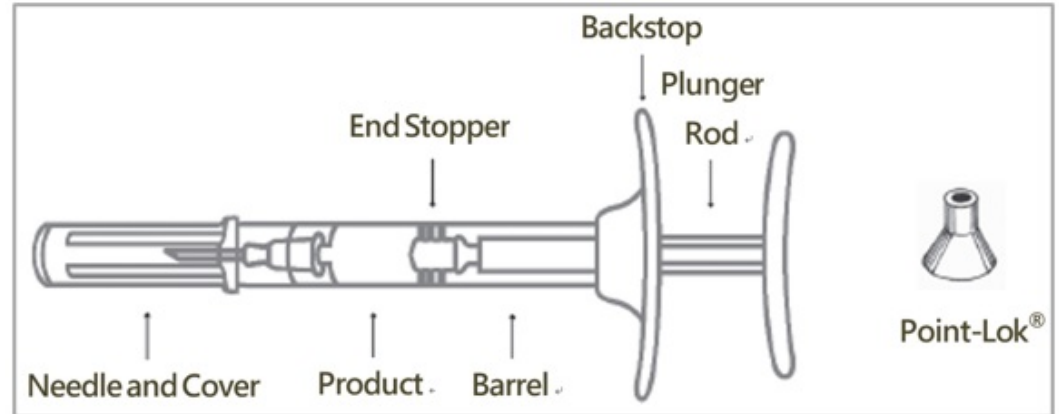

**Select an injection site**

**STEP To select an injection site, use these guidelines:**

Choose an injection site on the upper- or mid-abdominal area with sufficient soft or loose subcutaneous tissue that has not recently been used. Clean the injection site with an alcohol swab.



1

Do **NOT** inject in areas with brawny or fibrous subcutaneous tissue or locations that can be rubbed or compressed (i.e., with a belt or clothing waistband). In addition, avoid applying heat directly to the site of Camcevi injection.

**Inject CAMCEVI**

**STEP Follow these steps to inject CAMCEVI:**

- 1 Pull the blue cover off the needle (B). Use standard sharps safety techniques to avoid needle sticks. Use standard aseptic technique when performing the injection.



Grab and bunch the skin around the injection site with one hand. Insert the needle at a 90° angle to the skin surface, and then release the bunched skin.

2



3 Inject the full contents of the syringe with a slow and steady push on the plunger, and then withdraw the needle at the same 90° angle used for insertion.

Do not remove the needle from the syringe. Use the enclosed Point-Lok® device to prevent needle sticks.

Retrieve the Point-Lok® needle protection device from the Camcevi kit and place it on a secured, flat surface with its largest surface base touching the surface as shown in the diagram below.

Immediately after use of the needle, gently insert the exposed needle into the Point-Lok® device opening at the top of the Point-Lok® device. (see Figure 1 below)

Push the needle into the top opening until it is fully inserted into the Point-Lok® device. This action will seal the needle tip and lock the needle firmly into the Point-Lok® device. (see Figure 2 below)

4

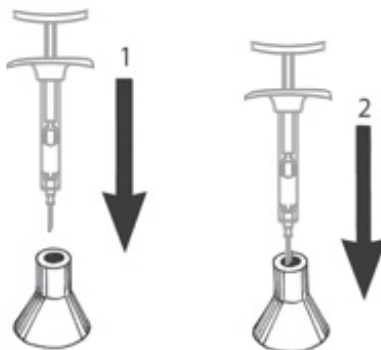

After use, place the used syringe with needle protected in a suitable sharps container. Dispose of contaminated product in a safe manner according to Centers for Disease Control and Prevention, USA and Federal/State/Local regulations (EPA, OSHA) and health care facility guidelines or local equivalent.

Manufactured for:

Foresee Pharmaceuticals Co. Ltd.

9F-2, No. 19-3, Sanchong Rd., Nangang Dist., Taipei City 115, Taiwan

By:  
Fareva Pau 1  
Avenue du Bearn, 64320 Idron, France

## PRINCIPAL DISPLAY PANEL- Carton

NDC 72851-042-01

Rx Only

### CAMCEVI™

(leuprolide) injectable emulsion

### 42 mg single-dose prefilled syringe

### Front

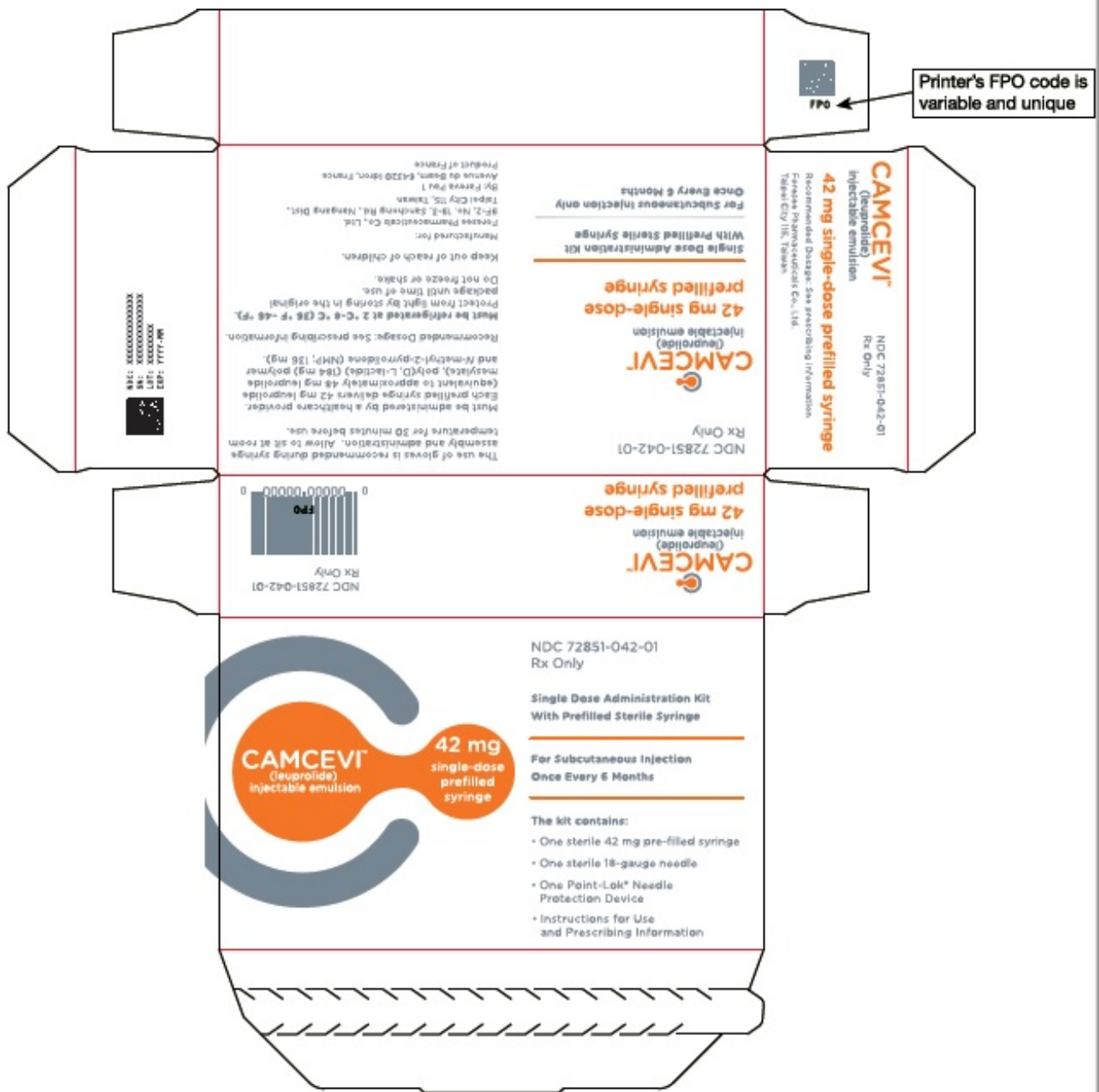

Back

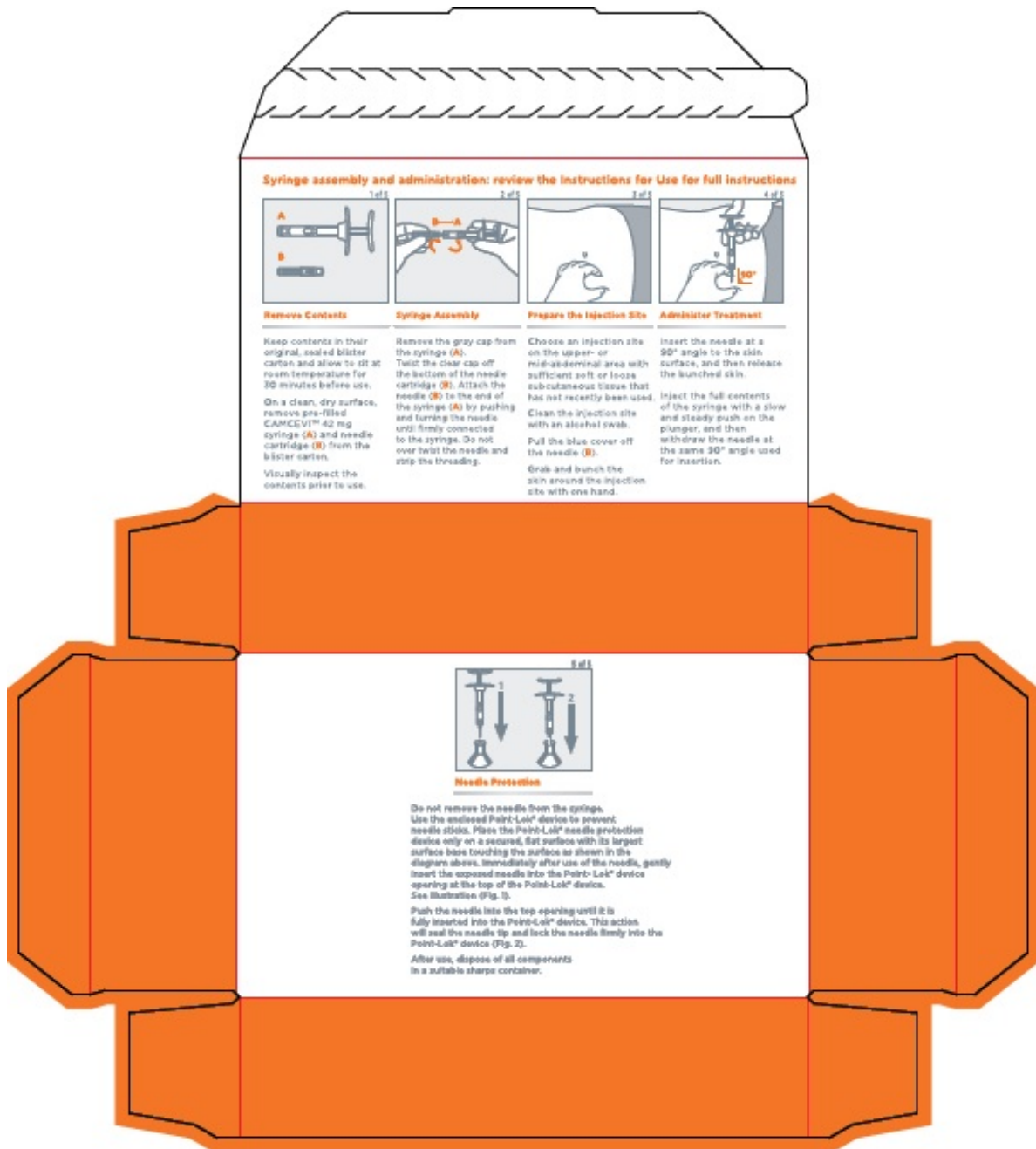

**PRINCIPAL DISPLAY PANEL- Syringe Label**

**NDC 72851-042-01**

**Rx Only**

**CAMCEVI™**

**(leuprolide) injectable emulsion**

**42 mg single-dose prefilled syringe**

**For Subcutaneous Injection Only**

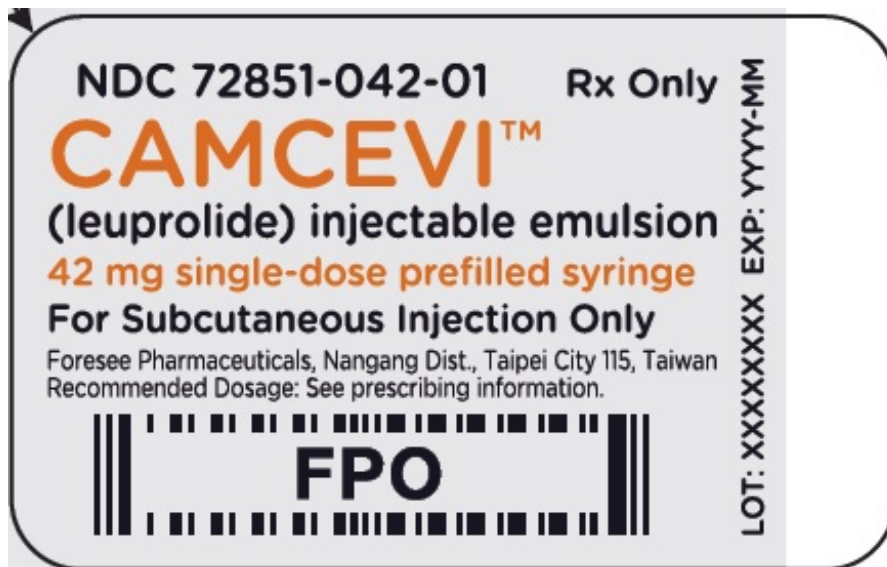

**PRINCIPAL DISPLAY PANEL- Outer Label**

NDC 72851-042-01

Rx Only

**CAMCEVI™**

(leuprolide) injectable emulsion

42 mg single-dose prefilled syringe

**This blister carton contains:**

- One sterile 42 mg pre-filled syringe
- One sterile 18-gauge needle

Single Dose Administration Kit with prefilled syringe

For Subcutaneous Injection Only once Every 6 Months

NDC 72851-042-01  
Rx Only

  
**CAMCEVI™**  
(leuprolide)  
injectable emulsion

42 mg single-dose prefilled syringe

**This blister carton contains:**

- One sterile 42 mg pre-filled syringe
- One sterile 18-gauge needle

Single Dose Administration Kit  
with prefilled syringe

For Subcutaneous Injection Only  
Once Every 6 Months

**Must be refrigerated at 2 °C-8 °C (36 °F-46 °F).**

Protect from light by storing in the original package until time of use.

Do not freeze or shake.

Allow prefilled syringe to sit at room temperature for 30 minutes prior to subcutaneous injection.

Must be administered by a healthcare provider.

Each prefilled syringe delivers 42 mg leuprolide (equivalent to approximately 48 mg leuprolide mesylate), poly(D, L-lactide) (184 mg) polymer and *N*-methyl-2-pyrrolidone (NMP; 136 mg)

The use of gloves is recommended during syringe assembly and administration.

Recommended Dosage: See prescribing information.

Manufactured for:

Foresee Pharmaceuticals Co., Ltd.

9F-2, No. 19-3, Sanchong Rd.,

Nangang Dist., Taipei City 115, Taiwan

By: Fareva Pau 1

Avenue du Bearn, 64320 Idron, France

Product of France

LOT: XXXXXXXXX  
EXP: YYYY-MM



## CAMCEVI

leuprolide injection, emulsion

### Product Information

|                                |                         |                           |               |
|--------------------------------|-------------------------|---------------------------|---------------|
| <b>Product Type</b>            | HUMAN PRESCRIPTION DRUG | <b>Item Code (Source)</b> | NDC:72851-042 |
| <b>Route of Administration</b> | SUBCUTANEOUS            |                           |               |

### Active Ingredient/Active Moiety

| Ingredient Name  | Basis of Strength | Strength      |
|--|-------------------|---------------|
| <b>LEUPROLIDE MESYLATE</b> (UNII: 8E3C3C493W) (LEUPROLIDE - UNII:EFY6W0M8TG) | LEUPROLIDE        | 42 mg in 1 mL |

### Inactive Ingredients

| Ingredient Name                             | Strength |
|---|----------|
| <b>POLYLACTIDE</b> (UNII: 459TN2L5F5)       |          |
| <b>METHYLPYRROLIDONE</b> (UNII: JR9CE63FPM) |          |

### Packaging

| # | Item Code        | Package Description | Marketing Start Date | Marketing End Date |
|---|------------------|---------------------|----------------------|--------------------|
| 1 | NDC:72851-042-01 | 1 in 1 CARTON       | 12/30/2022           |                    |

|                              |   |                             |                           |
|------------------------------|---|-----------------------------|---------------------------|
| <b>1</b>                     | 1 mL in 1 SYRINGE; Type 2: Prefilled Drug Delivery Device/System (syringe, patch, etc.) |                             |                           |
| <b>Marketing Information</b> |   |                             |                           |
| <b>Marketing Category</b>    | <b>Application Number or Monograph Citation</b>   | <b>Marketing Start Date</b> | <b>Marketing End Date</b> |
| NDA                          | NDA211488   | 12/30/2022                  |                           |

**Labeler** - Foresee Pharmaceuticals Co., Ltd. (656086537)

**Registrant** - Foresee Pharmaceuticals Co., Ltd. (656086537)

|                                    |                |               |                            |
|------------------------------------|----------------|---------------|----------------------------|
| <b>Establishment</b>               |                |               |                            |
| <b>Name</b>                        | <b>Address</b> | <b>ID/FEI</b> | <b>Business Operations</b> |
| Pierre Fabre Medicament Production |                | 504638276     | manufacture(72851-042)     |

|                         |                |               |                            |
|-------------------------|----------------|---------------|----------------------------|
| <b>Establishment</b>    |                |               |                            |
| <b>Name</b>             | <b>Address</b> | <b>ID/FEI</b> | <b>Business Operations</b> |
| ScinoPharm Taiwan, Ltd. |                | 657484726     | api manufacture(72851-042) |

Revised: 11/2021

Foresee Pharmaceuticals Co., Ltd.