

MATRIX BIOLAGE SCALPSYNC ANTIDANDRUFF- pyrithione zinc shampoo
L'Oreal USA Products Inc

Drug Facts

Active ingredient

Pyrithione zinc 1%

Purpose

Antidandruff

Use

fighting scalp scaling, itching and flaking due to dandruff

Warnings

For external use only

When using this product

avoid contact with the eyes. If contact occurs, rinse eyes thoroughly with water.

Stop use and ask a doctor if

condition worsens or does not improve after regular use

Keep out of reach of children.

If swallowed, get medical help or contact a Poison Control Center right away.

Directions

- for best results use at least twice a week or as directed by a physician
- shake well; apply evenly onto scalp
- leave on 1 - 3 minutes; rinse
- repeat if necessary

Inactive ingredients

water, sodium laureth sulfate, sodium lauryl sulfate, glycerin, cocamide MEA, glycol

distearate, sodium chloride, hexylene glycol, dimethicone, fragrance, citric acid, sodium benzoate, sodium hydroxide, coco-betaine, carbomer, menthol, guar hydroxypropyltrimonium chloride, limonene, sodium polynaphthalenesulfonate, salicylic acid, hexyl cinnamal, coumarin, benzyl alcohol, linalool, amyl cinnamal, pentylene glycol, mentha piperita (peppermint) extract, cellulose gum, fumaric acid, methylisothiazolinone

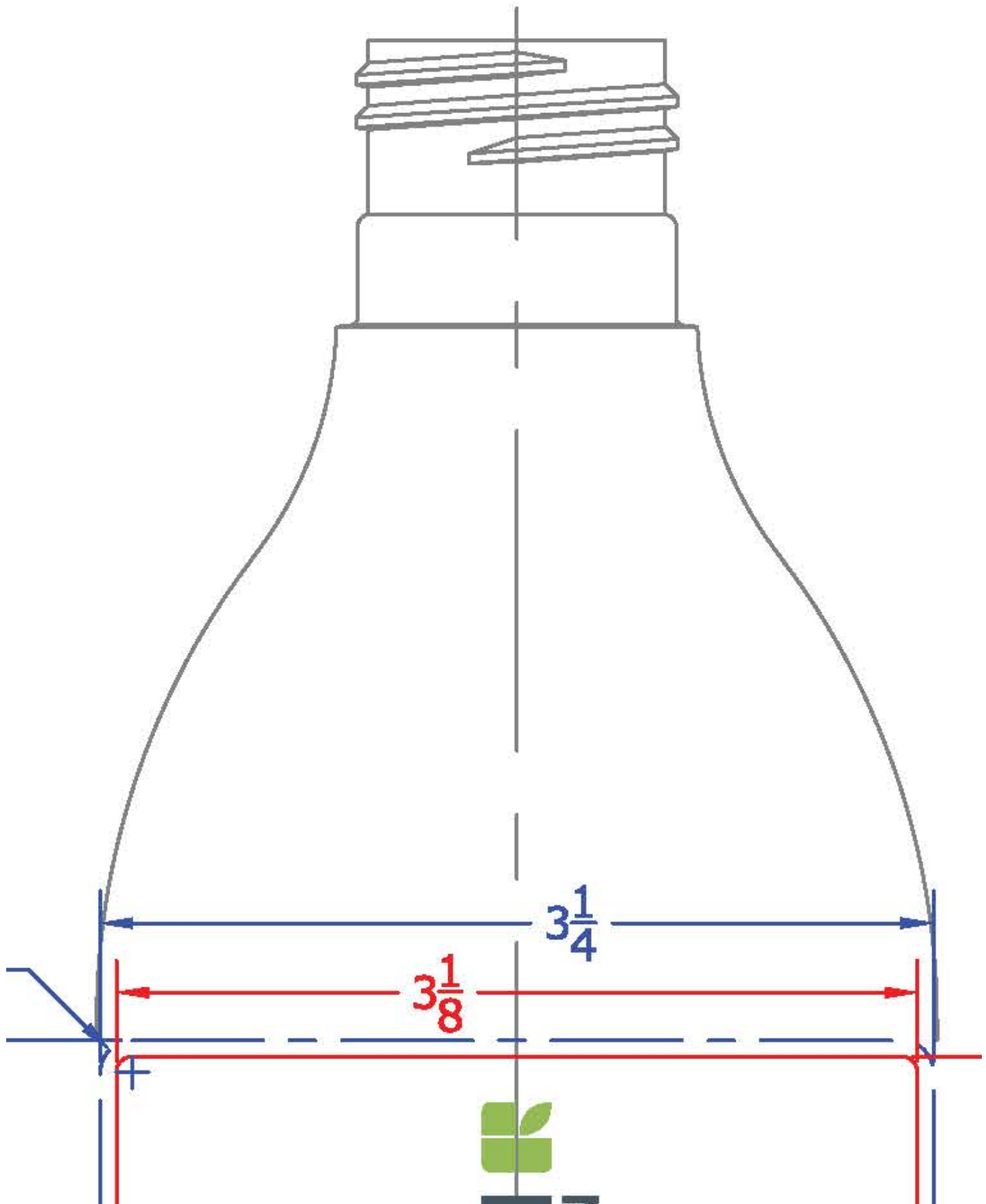

MATRIX BIOLAGGE

CENTERLINE
FRONT
PANEL



**SCALP
SYNC**

Pyrrithione Zinc

**Antidandruff
Shampoo**

Pyrrithione de Zinc

**Champú
Anticaspa**

For Dandruff Control
Para el Control de Caspa

33.8 FL.OZ. / 1L

0104958

1

2

3

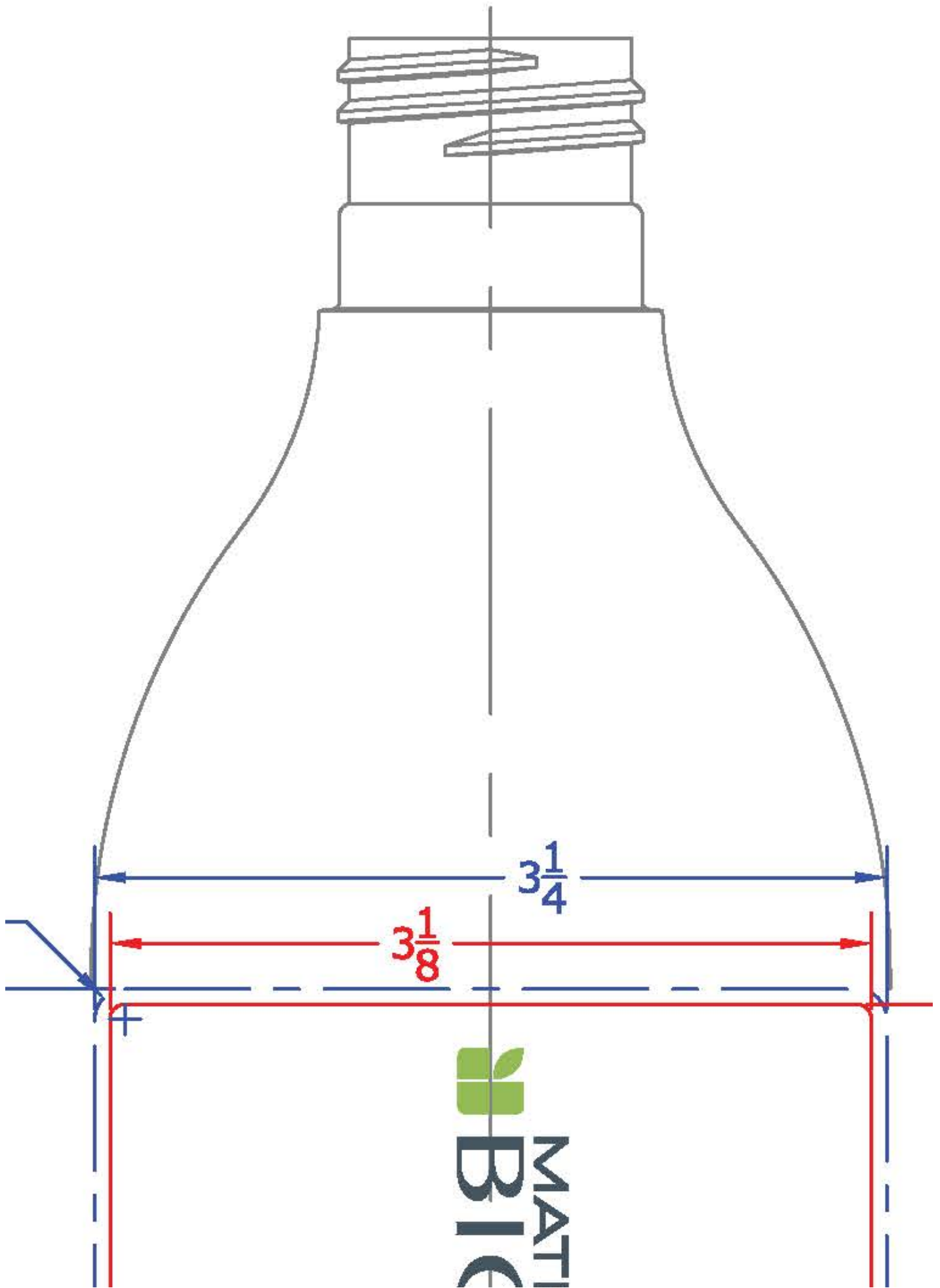

 MATI
BIC

RX
DUALGIE

CENTERLINE
FRONT
PANEL



**SCALP
SYNC**

Pyrrithione Zinc

**Antidandruff
Shampoo**

Pyrrithione de Zinc

**Champú
Anticaspa**

For Dandruff Control
Para el Control de Caspa

01104978

33.8 FL. OZ. / 1L

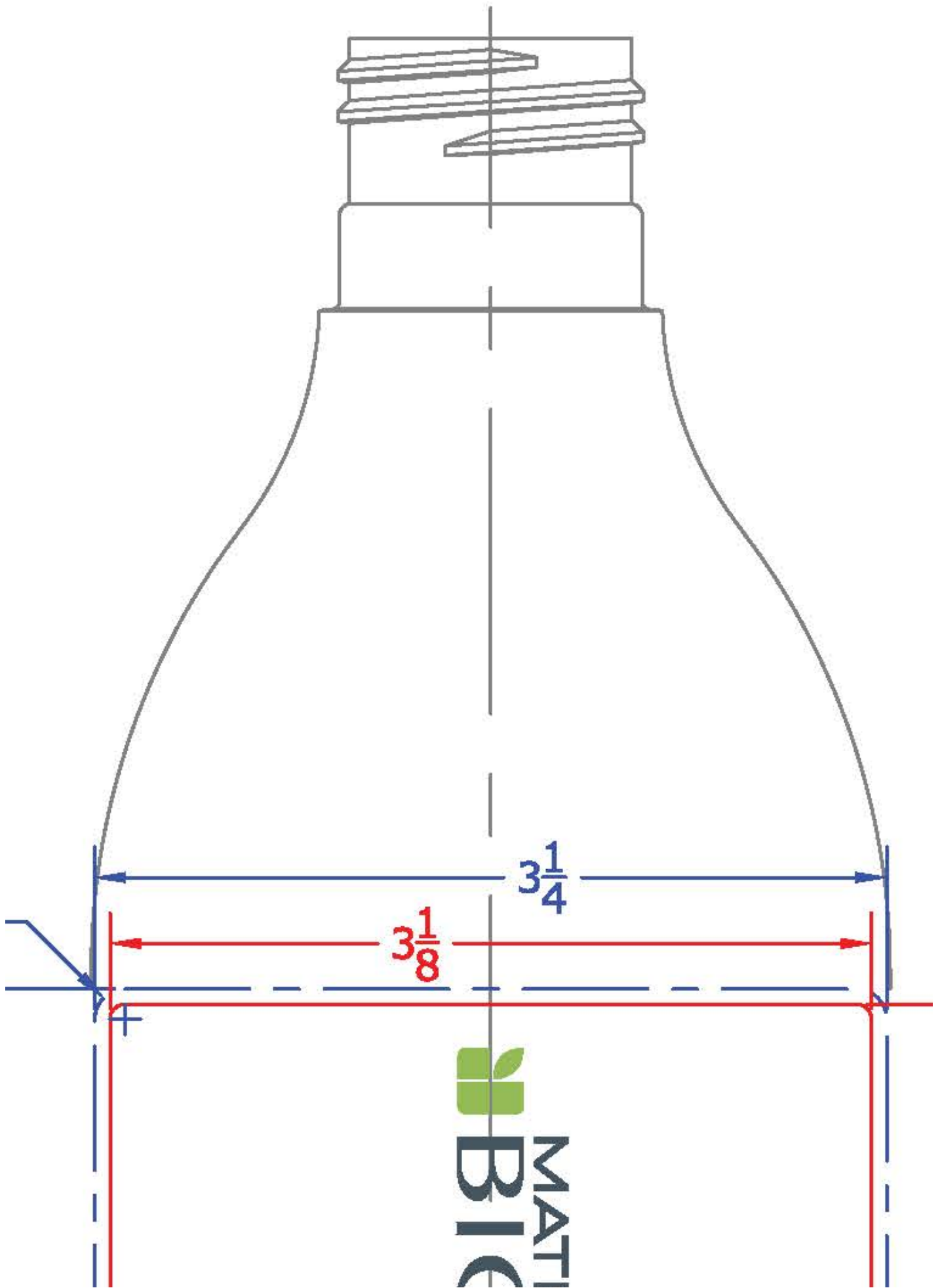

 MATI
BIC

RX
DUALGIE

CENTERLINE
FRONT
PANEL



**SCALP
SYNC**

Pyrrithione Zinc

**Antidandruff
Shampoo**

Pyrrithione de Zinc

**Champú
Anticaspa**

For Dandruff Control
Para el Control de Caspa

01104968

33.8 FL. OZ. / 1L

SCALPSYNC helps balance the scalp and leaves hair clean and healthy-looking. **SCALPSYNC** Antidandruff Shampoo with Pyrithione Zinc helps eliminate the symptoms of dandruff, controls scalp flaking and relieves scalp irritation with continued use. Suitable for color-treated hair. **DERMATOLOGIST TESTED FOR SAFETY.**

SCALPSYNC ayuda a equilibrar el cuero cabelludo, dejando el cabello limpio y sano. **SCALPSYNC** Champú Anti-caspa contiene Píritona de Zinc que ayuda a eliminar los síntomas de la caspa, controlando la descamación y aliviando la irritación del cuero cabelludo con el uso continuo. Adecuado para cabello con color. **MODO DE EMPLEO:** Aplicar sobre cabellos húmedos. Emulsionar. Enjuagar. En caso de contacto con los ojos, enjuagarlos inmediatamente. **DERMATOLÓGICAMENTE TESTADO PARA SU SEGURIDAD.**

Drug Facts

Active ingredient	Purpose
Pyrithione zinc 1%	Antidandruff

Use
fights scalp scaling, itching and flaking due to dandruff

Warnings
For external use only
When using this product avoid contact with the eyes. If contact occurs, rinse eyes thoroughly with water.

Stop use and ask a doctor if condition worsens or does not improve after regular use
Keep out of reach of children. If swallowed, get medical help or contact a Poison Control Center right away.

Directions
• for best results use at least twice a week or as directed by a physician
• shake well; apply evenly onto scalp
• leave on 1-3 minutes; rinse
• repeat if necessary

Inactive ingredients water, sodium laureth sulfate, sodium lauryl sulfate, glycerin, cocamide MEA, glycol distearate, sodium chloride, hexylene glycol, dimethicone, fragrance, citric acid, sodium benzoate, sodium hydroxide, coco-betaine, carbomer, menthol, guar hydroxypropyltrimonium chloride, limonene, sodium polynaphthalenesulfonate, salicylic acid, hexyl cinnamal, coumarin, benzyl alcohol, linalool, amyl cinnamal, pentylene glycol, mentha piperita extract / peppermint extract, cellulose gum, fumaric acid, methylisothiazolinone

QUESTIONS OR COMMENTS? **1218030MX** F.I.L. 0239965/1
CALL THE MATRIX HOTLINE: 1-888-777-6396 PAT: patents.biologie.com

Datos del Medicamento

Ingrediente activo	Propósito
Píritona de zinc 1%	Anticaspa

Uso
combate la escamosidad del cuero cabelludo, la picazón y las escamas producidas por la caspa.

Advertencias
Para uso externo solamente
Al usar este producto debe evitarse el contacto con los ojos. Si éste se produjera, enjuagar bien con agua.

Deje de usar el producto y consulte a su médico si la condición empeora no mejora con uso regular
Mantener el producto fuera del alcance de los niños. Si se ingiere, buscar asistencia médica o comunicarse con el Centro del Control de Envenenamiento de manera inmediata.

Indicaciones
• para óptimos resultados úselo por lo menos dos veces por semana o según lo indique el médico
• agitar bien y aplicar de manera uniforme en todo el cuero cabelludo
• dejar actuar de 1 a 3 minutos; enjuagar
• repetir si es necesario

Ingredientes inactivos agua, sodium laureth sulfate, sodium lauryl sulfate, glycerin, cocamide MEA, glycol distearate, sodium chloride, hexylene glycol, dimethicone, fragrance, citric acid, sodium benzoate, sodium hydroxide, coco-betaine, carbomer, menthol, guar hydroxypropyltrimonium chloride, limonene, sodium polynaphthalenesulfonate, salicylic acid, hexyl cinnamal, coumarin, benzyl alcohol, linalool, amyl cinnamal, pentylene glycol, mentha piperita extract / peppermint extract, cellulose gum, fumaric acid, methylisothiazolinone

PREGUNTAS/COMENTARIOS? **1218030MX** F.I.L. 0239965/1
LLAME A LA LÍNEA DE SERVICIO **PAT: patents.biologie.com**
DE MATRIX: 1-888-777-6396



MADE IN/HECO EN U.S.A. OF U.S. AND/OR IMPORTED INGREDIENTS; BIOLAGE LLC, NEW YORK, NY 10001; IMP. BY/POR BIOLAGE CANADA, MONTREAL H4T 1K5; BIOLAGE 15, RUE SAINT FLORENTIN 75008 PARIS TSA 75000 93584 ST OUEN CEDEX FR

www.biologie.com



UNCOATED
WHITE LOT CODE AREA

1811339

2D
CODE

SCALPSYNC helps balance the scalp and leaves hair clean and healthy-looking. **SCALPSYNC** Antidandruff Shampoo with Pyrithione Zinc helps eliminate the symptoms of dandruff, controls scalp flaking and relieves scalp irritation with continued use. Suitable for color-treated hair. **DERMATOLOGIST TESTED FOR SAFETY.**

SCALPSYNC ayuda a equilibrar el cuero cabelludo, dejando el cabello limpio y sano. **SCALPSYNC** Champú Anti-caspa contiene Píritona de Zinc que ayuda a eliminar los síntomas de la caspa, controlando la descamación y aliviando la irritación del cuero cabelludo con el uso continuo. Adecuado para cabello con color. **MODO DE EMPLEO:** Aplicar sobre cabellos húmedos. Emulsionar. Enjuagar. En caso de contacto con los ojos, enjuagarlos inmediatamente. **DERMATOLÓGICAMENTE TESTADO PARA SU SEGURIDAD.**

Drug Facts

Active ingredient	Purpose
Pyrithione zinc 1%	Antidandruff

Use
fights scalp scaling, itching and flaking due to dandruff

Warnings
For external use only
When using this product avoid contact with the eyes. If contact occurs, rinse eyes thoroughly with water.
Stop use and ask a doctor if condition worsens or does not improve after regular use
Keep out of reach of children. If swallowed, get medical help or contact a Poison Control Center right away.

Directions
• for best results use at least twice a week or as directed by a physician
• shake well; apply evenly onto scalp
• leave on 1-3 minutes; rinse
• repeat if necessary

Inactive ingredients water, sodium laureth sulfate, sodium lauryl sulfate, glycerin, cocamide MEA, glycol distearate, sodium chloride, hexylene glycol, dimethicone, fragrance, citric acid, sodium benzoate, sodium hydroxide, coco-betaine, carbomer, menthol, guar hydroxypropyltrimonium chloride, limonene, sodium polynaphthalenesulfonate, salicylic acid, hexyl cinnamal, coumarin, benzyl alcohol, linalool, amyl cinnamal, pentylene glycol, mentha piperita extract / peppermint extract, cellulose gum, fumaric acid, methylisothiazolinone

QUESTIONS OR COMMENTS? **1218030MX** F.I.L. 023905/1
CALL THE MATRIX HOTLINE: 1-888-777-6396 PAT: patents.biologie.com

Datos del Medicamento

Ingrediente activo	Propósito
Píritona de zinc 1%	Anticaspa

Uso
combate la escamosidad del cuero cabelludo, la picazón y las escamas producidas por la caspa.

Advertencias
Para uso externo solamente
Al usar este producto debe evitarse el contacto con los ojos. Si éste se produjera, enjuagar bien con agua.

Deje de usar el producto y consulte a su médico si la condición empeora no mejora con uso regular
Mantener el producto fuera del alcance de los niños. Si se ingiere, buscar asistencia médica o comunicarse con el Centro del Control de Envenenamiento de manera inmediata.

Indicaciones
• para óptimos resultados úselo por lo menos dos veces por semana o según lo indique el médico
• agitar bien y aplicar de manera uniforme en todo el cuero cabelludo
• dejar actuar de 1 a 3 minutos; enjuagar
• repetir si es necesario

Ingredientes inactivos agua, sodium laureth sulfate, sodium lauryl sulfate, glycerin, cocamide MEA, glycol distearate, sodium chloride, hexylene glycol, dimethicone, fragrance, citric acid, sodium benzoate, sodium hydroxide, coco-betaine, carbomer, menthol, guar hydroxypropyltrimonium chloride, limonene, sodium polynaphthalenesulfonate, salicylic acid, hexyl cinnamal, coumarin, benzyl alcohol, linalool, amyl cinnamal, pentylene glycol, mentha piperita extract / peppermint extract, cellulose gum, fumaric acid, methylisothiazolinone

PREGUNTAS/COMENTARIOS? **1218030MX** F.I.L. 023905/1
LLAME A LA LÍNEA DE SERVICIO **PAT: patents.biologie.com**
DE MATRIX: 1-888-777-6396



MADE IN/HECO EN U.S.A. OF U.S. AND/OR IMPORTED INGREDIENTS; BIOLAGE LLC, NEW YORK, NY 10001; IMP. BY/POR BIOLAGE CANADA, MONTREAL H4T 1K5; BIOLAGE 15, RUE SAINT FLORENTIN 75008 PARIS TSA 75000 93584 ST OUEN CEDEX FR

www.biologie.com



UNCOATED
WHITE LOT CODE AREA

1811339

2D
CODE

SCALPSYNC helps balance the scalp and leaves hair clean and healthy-looking. **SCALPSYNC** Antidandruff Shampoo with Pyrithione Zinc helps eliminate the symptoms of dandruff, controls scalp flaking and relieves scalp irritation with continued use. Suitable for color-treated hair. **DERMATOLOGIST TESTED FOR SAFETY.**

SCALPSYNC ayuda a equilibrar el cuero cabelludo, dejando el cabello limpio y sano. **SCALPSYNC** Champú Anti-caspa contiene Piritiona de Zinc que ayuda a eliminar los síntomas de la caspa, controlando la descamación y aliviando la irritación del cuero cabelludo con el uso continuo. Adecuado para cabello con color. **MODO DE EMPLEO:** Aplicar sobre cabellos húmedos. Emulsionar. Enjuagar. En caso de contacto con los ojos, enjuagarlos inmediatamente. **DERMATOLÓGICAMENTE TESTADO PARA SU SEGURIDAD.**

Drug Facts

Active ingredient	Purpose
Pyrithione zinc 1%.....	Antidandruff

Use
fights scalp scaling, itching and flaking due to dandruff

Warnings
For external use only

When using this product avoid contact with the eyes. If contact occurs, rinse eyes thoroughly with water.

Stop use and ask a doctor if condition worsens or does not improve after regular use

Keep out of reach of children. If swallowed, get medical help or contact a Poison Control Center right away.

Directions

- for best results use at least twice a week or as directed by a physician
- shake well; apply evenly onto scalp
- leave on 1-3 minutes; rinse
- repeat if necessary

Inactive ingredients water, sodium laureth sulfate, sodium lauryl sulfate, glycerin, cocamide MEA, glycol distearate, sodium chloride, hexylene glycol, dimethicone, fragrance, citric acid, sodium benzoate, sodium hydroxide, coco-betaine, carbomer, menthol, guar hydroxypropyltrimonium chloride, limonene, sodium polynaphthalenesulfonate, salicylic acid, hexyl cinnamal, coumarin, benzyl alcohol, linalool, amyl cinnamal, pentylene glycol, mentha piperita extract / peppermint extract, cellulose gum, fumaric acid, methylisothiazolinone

QUESTIONS OR COMMENTS? **1218030MX** F.I.L. 023905/1
CALL THE MATRIX HOTLINE 1-888-777-6396 PAT: patents.biolage.com

Datos del Medicamento

Ingrediente activo	Propósito
Piritiona de zinc 1%.....	Anticaspa

Uso
combate la escamosidad del cuero cabelludo, la picazón y las escamas producidas por la caspa.

Advertencias
Para uso externo solamente

Al usar este producto debe evitarse el contacto con los ojos. Si éste se produjera, enjuagar bien con agua.

Deje de usar el producto y consulte a su médico si la condición empeora no mejora con uso regular

Mantener el producto fuera del alcance de los niños. Si se ingiere, buscar asistencia médica o comunicarse con el Centro del Control de Envenenamiento de manera inmediata.

Indicaciones

- para óptimos resultados úselo por lo menos dos veces por semana o según lo indique el médico
- agitar bien y aplicar de manera uniforme en todo el cuero cabelludo
- dejar actuar de 1 a 3 minutos; enjuagar
- repetir si es necesario

Ingredientes inactivos agua, sodium laureth sulfate, sodium lauryl sulfate, glycerin, cocamide MEA, glycol distearate, sodium chloride, hexylene glycol, dimethicone, fragrance, citric acid, sodium benzoate, sodium hydroxide, coco-betaine, carbomer, menthol, guar hydroxypropyltrimonium chloride, limonene, sodium polynaphthalenesulfonate, salicylic acid, hexyl cinnamal, coumarin, benzyl alcohol, linalool, amyl cinnamal, pentylene glycol, mentha piperita extract / peppermint extract, cellulose gum, fumaric acid, methylisothiazolinone

PREGUNTAS/COMENTARIOS? **1218030MX** F.I.L. 023905/1
LLAME A LA LÍNEA DE SERVICIO **1218030MX** PAT: patents.biolage.com
DE MATRIX: 1-888-777-6396



MADE IN/HECO EN U.S.A. OF U.S. AND/OR IMPORTED INGREDIENTS; BIOLAGE LLC, NEW YORK, NY 10001; IMP. BY/POR BIOLAGE CANADA, MONTREAL H4T 1K5; BIOLAGE 15, RUE SAINT FLORENTIN 75008 PARIS TSA 75000 93584 ST OUEN CEDEX FR

www.biolage.com



UNCOATED
WHITE LOT CODE AREA

1811339



pyrithione zinc shampoo

Product Information

Product Type	HUMAN OTC DRUG	Item Code (Source)	NDC:49967-052
Route of Administration	TOPICAL		

Active Ingredient/Active Moiety

Ingredient Name	Basis of Strength	Strength
PYRITHIONE ZINC (UNII: R953O2RHZ5) (PYRITHIONE ZINC - UNII:R953O2RHZ5)	PYRITHIONE ZINC	10 mg in 1 mL

Inactive Ingredients

Ingredient Name	Strength
WATER (UNII: 059QF0KO0R)	
SODIUM LAURETH SULFATE (UNII: BPV390UAP0)	
SODIUM LAURYL SULFATE (UNII: 368GB5141J)	
GLYCERIN (UNII: PDC6A3C0OX)	
COCO MONOETHANOLAMIDE (UNII: C80684146D)	
GLYCOL DISTEARATE (UNII: 13W7MDN21W)	
SODIUM CHLORIDE (UNII: 451W47IQ8X)	
HEXYLENE GLYCOL (UNII: KEH0A3F75J)	
DIMETHICONE (UNII: 92RU3N3Y1O)	
CITRIC ACID MONOHYDRATE (UNII: 2968PHW8QP)	
SODIUM BENZOATE (UNII: OJ245FE5EU)	
SODIUM HYDROXIDE (UNII: 55X04QC32I)	
COCO-BETAINE (UNII: 03DH2IZ3FY)	
CARBOMER HOMOPOLYMER, UNSPECIFIED TYPE (UNII: 0A5MM307FC)	
MENTHOL (UNII: L7T10EIP3A)	
GUAR HYDROXYPROPYLTRIMONIUM CHLORIDE (1.7 SUBSTITUENTS PER SACCHARIDE) (UNII: B16G315W7A)	
LIMONENE, (+)- (UNII: GFD7C86Q1W)	
SALICYLIC ACID (UNII: O414PZ4LPZ)	
.ALPHA.-HEXYLCINNAMALDEHYDE (UNII: 7X6O37OK2I)	
COUMARIN (UNII: A4VZ22K1WT)	
BENZYL ALCOHOL (UNII: LKG8494WBH)	
LINALOOL, (+/-)- (UNII: D81QY6I88E)	
.ALPHA.-AMYL CINNAMALDEHYDE (UNII: WC51CA3418)	
PENTYLENE GLYCOL (UNII: 50C1307PZG)	
MENTHA X PIPERITA WHOLE (UNII: 79M2M2UDA9)	
CARBOXYMETHYLCELLULOSE SODIUM, UNSPECIFIED (UNII: K679OBS311)	
FUMARIC ACID (UNII: 88XHZ13131)	
METHYLISOTHIAZOLINONE (UNII: 229D0E1QFA)	

Packaging

#	Item Code	Package Description	Marketing Start	Marketing End
---	-----------	---------------------	-----------------	---------------

#	Item Code	Package Description	Date	Date
1	NDC:49967-052-01	400 mL in 1 BOTTLE; Type 0: Not a Combination Product	05/01/2014	
2	NDC:49967-052-02	1000 mL in 1 BOTTLE; Type 0: Not a Combination Product	05/01/2014	
3	NDC:49967-052-03	50 mL in 1 BOTTLE; Type 0: Not a Combination Product	02/01/2024	

Marketing Information

Marketing Category	Application Number or Monograph Citation	Marketing Start Date	Marketing End Date
OTC Monograph Drug	M032	05/01/2014	

Labeler - L'Oreal USA Products Inc (002136794)

Establishment

Name	Address	ID/FEI	Business Operations
L'Oreal USA, INC.		960317444	manufacture(49967-052) , pack(49967-052)

Revised: 7/2024

L'Oreal USA Products Inc