

# DEXTROSE- dextrose monohydrate injection

## Baxter Healthcare Corporation

-----

### HIGHLIGHTS OF PRESCRIBING INFORMATION

These highlights do not include all the information needed to use DEXTROSE INJECTION safely and effectively. See full prescribing information for DEXTROSE INJECTION.

DEXTROSE Injection, for intravenous use

Initial U.S. Approval: 1940

### RECENT MAJOR CHANGES

Dosage and Administration (2.1, 2.3) 12/2022

### INDICATIONS AND USAGE

Dextrose Injection is indicated as a source of calories and water and may also be used as diluent for reconstitution of a powdered or liquid (up to 10 mL) drug product packaged in a vial with a 13mm or 20mm closure. (1)

### DOSAGE AND ADMINISTRATION

- Only for intravenous infusion. (2.1)
- See full prescribing information for information on preparation, administration, dosing considerations and instructions for use. (2.1, 2.2, 2.3)

### DOSAGE FORMS AND STRENGTHS

Injection: 5% (0.05 grams/mL), 5 grams of dextrose hydrous per 100 mL in 50 mL and 100 mL single-dose, flexible containers (3)

### CONTRAINDICATIONS

- Clinically significant hyperglycemia. (4)
- Known hypersensitivity to dextrose. (4)

### WARNINGS AND PRECAUTIONS

- Hyperglycemia or Hyperosmolar Hyperglycemic State: Monitor blood glucose and administer insulin as needed. (5.1)
- Hypersensitivity Reactions: Monitor for signs and symptoms and discontinue infusion if reactions occur. (5.2)
- Vein Damage and Thrombosis: Consider central vein when administering more than 5% dextrose or with an osmolality of  $\geq 900$  mOsm/L or when there is peripheral vein irritation, phlebitis, and/or associated pain. (2.2, 5.3)
- Hyponatremia: Avoid in patients with or at risk for hyponatremia. If use cannot be avoided, monitor serum sodium concentrations (5.4)
- Electrolyte Imbalance and Fluid Overload: Avoid in patients with or at risk for fluid and/or solute overloading. If use cannot be avoided, monitor daily fluid balance, electrolyte concentrations, and acid-base balance, as needed and especially during prolonged use (5.5)
- Refeeding Syndrome: Monitor severely undernourished patients and slowly increase nutrient intake. (5.6)

### ADVERSE REACTIONS

The most common adverse reactions are, hyperglycemia, hypersensitivity reactions, hyponatremia, infection both systemic and at the injection site, vein thrombosis or phlebitis, and electrolyte imbalance. (6)

**To report SUSPECTED ADVERSE REACTIONS, contact Baxter Healthcare at 1-866-888-2472 or FDA at 1-800-FDA-1088 or [www.fda.gov/medwatch](http://www.fda.gov/medwatch).**

### DRUG INTERACTIONS

Other Products that Affect Glycemic Control, Vasopressin or Fluid and/or Electrolyte Balance: Monitor blood glucose concentrations, fluid balance, serum electrolyte concentrations and acid-base balance. (7.1)

### USE IN SPECIFIC POPULATIONS

Pediatric Use: Increased risk of hypoglycemia/hyperglycemia; monitor serum glucose concentrations. (8.4)

**See 17 for PATIENT COUNSELING INFORMATION.**

**Revised: 12/2022**

---

## **FULL PRESCRIBING INFORMATION: CONTENTS\***

### **1 INDICATIONS AND USAGE**

### **2 DOSAGE AND ADMINISTRATION**

- 2.1 Important Administration Instructions
- 2.2 Recommended Dosage
- 2.3 Instructions for Use

### **3 DOSAGE FORMS AND STRENGTHS**

### **4 CONTRAINDICATIONS**

### **5 WARNINGS AND PRECAUTIONS**

- 5.1 Hyperglycemia and Hyperosmolar Hyperglycemic State
- 5.2 Hypersensitivity Reactions
- 5.3 Vein Damage and Thrombosis
- 5.4 Hyponatremia
- 5.5 Electrolyte Imbalance and Fluid Overload
- 5.6 Refeeding Syndrome

### **6 ADVERSE REACTIONS**

### **7 DRUG INTERACTIONS**

- 7.1 Other Products that Affect Glycemic Control or Fluid and/or Electrolyte Balance

### **8 USE IN SPECIFIC POPULATIONS**

- 8.1 Pregnancy
- 8.2 Lactation
- 8.4 Pediatric Use
- 8.5 Geriatric Use

### **10 OVERDOSAGE**

### **11 DESCRIPTION**

### **12 CLINICAL PHARMACOLOGY**

- 12.1 Mechanism of Action

### **16 HOW SUPPLIED/STORAGE AND HANDLING**

### **17 PATIENT COUNSELING INFORMATION**

\* Sections or subsections omitted from the full prescribing information are not listed.

---

## **FULL PRESCRIBING INFORMATION**

### **1 INDICATIONS AND USAGE**

Dextrose Injection is indicated as source of water and calories and may also be used as diluent for reconstitution of a powdered or liquid (up to 10 mL) drug product packaged in a vial with a 13 mm or 20 mm closure.

### **2 DOSAGE AND ADMINISTRATION**

## 2.1 Important Administration Instructions

- Dextrose Injection is intended for intravenous use.
- Peripheral administration of 5% dextrose is generally acceptable, however, consider central vein when administering more than 5% dextrose or with an osmolarity of at least 900 mOsm/L or when there is peripheral vein irritation, phlebitis, and/or associated pain [see *Warnings and Precautions (5.3)*].
- Do not administer Dextrose Injection simultaneously with blood products through the same administration set because of the possibility of pseudoagglutination or hemolysis.
- To prevent air embolism, use a non-vented infusion set or close the vent on a vented set, avoid multiple connections, do not connect flexible containers in series, do not pressurize the flexible container to increase flow rates, and if administration is controlled by a pumping device, turn off pump before the container runs dry.
- Prior to infusion, visually inspect the infusion solution for particulate matter. The solution should be clear and there should be no precipitates. Do not administer unless solution is clear and container is undamaged.
- Use of a final filter is recommended during administration of parenteral solutions, where possible.
- Consult the full prescribing information of the medication to be added. Prior to adding the medication, verify that it is soluble and/or stable in Dextrose Injection and that the pH range is appropriate.

## 2.2 Recommended Dosage

The choice of dextrose concentration, rate and volume depends on the age, weight, clinical and metabolic conditions of the patient and concomitant therapy. Electrolyte supplementation may be indicated according to the clinical needs of the patient.

The administration rate should be governed, especially for premature infants with low birth weight, during the first few days of therapy, by the patient's tolerance to dextrose.

Increase the infusion rate gradually as indicated by frequent monitoring of blood glucose concentrations [see *Warnings and Precautions (5.1)*, *Use in Specific Populations (8.4)*].

## 2.3 Instructions for Use

### To Open

- Do not remove from overpouch until ready to use.
- Tear overwrap sharply down from the slit and remove solution container. Small amounts of moisture may be found on the solution container from water permeating from inside the container. The amount of permeated water is insufficient to affect the solution significantly. If larger amounts of water are found, the container should be checked for tears or leaks.
- Visually inspect the container. Some opacity of the plastic due to moisture absorption during the sterilization process may be observed. This is normal and does not affect the solution quality or safety. The opacity will diminish gradually. Evaluate the following:
  - If the outlet port protector is damaged, detached, or not present, discard container.

- Check to ensure the solution is clear and there are no precipitates. Discard if there is a color change and/or the appearance of precipitates, insoluble complexes or crystals.
- Check for leaks by separately squeezing the inner bag firmly. If leaks are found, discard container.
- Check that the vial adaptor cover is intact. If the vial adaptor cover is not intact, discard product.

### Preparation for Administration

- Use aseptic technique to attach the vial to the adaptor.

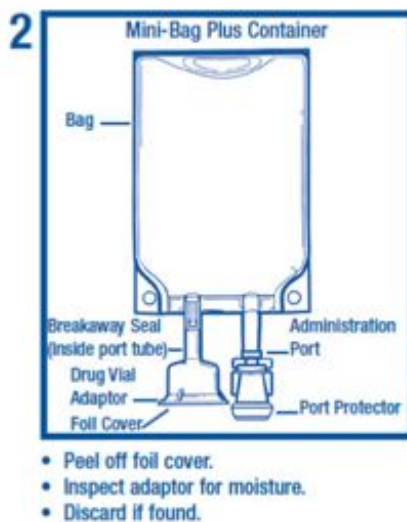
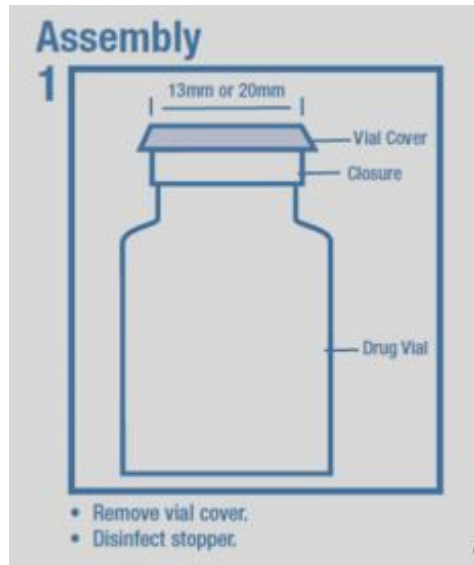

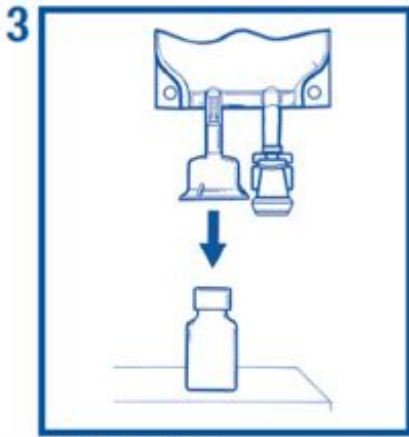

- Place vial upright.
- Hold firmly.
- Push adaptor down until vial snaps in place.
- DO NOT TWIST.

## Reconstitution

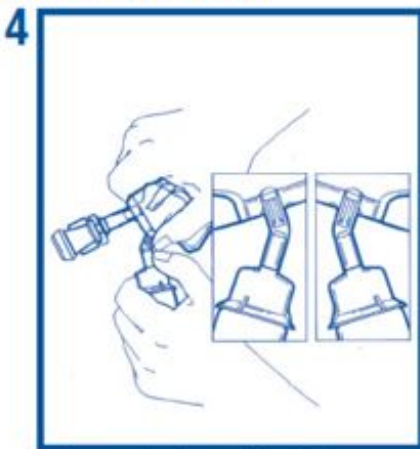

- Squeeze the bag and check vial.
- Use only if vial is fully seated and dry.
- With vial in an upright position break the seal by fully bending back and forth until a clear gap is observed in the breakaway seal.

5



- For liquid drug vials proceed directly to Step 6.
- For powdered drug vials:
  - Hold bag with vial down.
  - Squeeze solution into vial until half full.
  - Shake to suspend drug in solution.

6



- Hold bag with vial upside down.
- Squeeze bag to force air into vial.
- Release to drain suspended drug from vial.
- Repeat steps 5 and 6 until vial is empty of drug and solution is thoroughly mixed. Ensure drug is completely dissolved.  
Do Not Remove Drug Vial.

7. Remove port protector. Attach administration set per its directions.
8. Hang container on I.V. pole and prime set per directions. Ensure that vial is empty of drug and solution. Repeat step 6 if drug and solution remain in vial.

Warning: Do not use in series connections.

9. Administer medication per institutional practices.
10. Use within specified time for drug stability.
11. Discard unused portion.

### Storage of the infusion solution

Consult the full prescribing information of the added medication.

## **3 DOSAGE FORMS AND STRENGTHS**

Dextrose Injection, USP is a clear, sterile, non-pyrogenic solution supplied as 5 grams of dextrose hydrous per 100 mL (0.05 grams/mL) in 50 mL and 100 mL single-dose, flexible containers.

## **4 CONTRAINDICATIONS**

The use of Dextrose Injection is contraindicated in patients with:

- Clinically significant hyperglycemia [see *Warnings and Precautions (5.1)*].
- Known hypersensitivity to dextrose [see *Warnings and Precautions (5.2)*].

## **5 WARNINGS AND PRECAUTIONS**

### **5.1 Hyperglycemia and Hyperosmolar Hyperglycemic State**

The use of dextrose infusions in patients with impaired glucose tolerance may worsen hyperglycemia. Administration of dextrose at a rate exceeding the patient's utilization rate may lead to hyperglycemia, coma, and death.

Hyperglycemia is associated with an increase in serum osmolality, resulting in osmotic diuresis, dehydration and electrolyte losses [see *Warnings and Precautions (5.5)*]. Patients with underlying CNS disease and renal impairment who receive dextrose infusions, may be at greater risk of developing hyperosmolar hyperglycemic state.

Monitor blood glucose levels and treat hyperglycemia to maintain levels within normal limits while administering Dextrose Injection. Insulin may be administered or adjusted to maintain optimal blood glucose levels during Dextrose Injection administration.

### **5.2 Hypersensitivity Reactions**

Hypersensitivity and infusion reactions including anaphylaxis, have been reported with Dextrose Injection [see *Adverse Reactions (6)*]. Stop infusion immediately and treat patient accordingly if signs or symptoms of a hypersensitivity reaction develop. Appropriate therapeutic countermeasures must be instituted as clinically indicated.

### **5.3 Vein Damage and Thrombosis**

Peripheral administration of 5% Dextrose Injection is generally acceptable, however, consider central vein when administering more than 5% dextrose or with an osmolality of  $\geq 900$  mOsm/L or when there is peripheral vein irritation, phlebitis, and/or associated pain [see *Dosage and Administration (2.1)*]. The infusion of hypertonic solutions into a peripheral vein may result in vein irritation, vein damage, and/or thrombosis. The primary complication of peripheral access is venous thrombophlebitis, which manifests as pain, erythema, tenderness or a palpable cord. Remove the catheter as soon as possible, if thrombophlebitis develops.

### **5.4 Hyponatremia**

5% Dextrose Injection is an isotonic solution [see *Description, Table 1 (11)*]. In the body, however, glucose containing fluids can become extremely physiologically hypotonic due to rapid glucose metabolism. Monitoring of serum sodium is particularly important for

hypotonic fluids.

Depending on the tonicity of the solution, the volume and rate of infusion, and depending on a patient's underlying clinical condition and capability to metabolize glucose, intravenous administration of glucose can cause electrolyte disturbances, most importantly hypo- or hyperosmotic hyponatremia. Monitor serum sodium to minimize the risk of hyponatremia.

The risk for hyponatremia is increased in pediatric patients, elderly patients, postoperative patients, those with psychogenic polydipsia, and in patients treated with medications that increase the risk of hyponatremia (such as diuretics, certain antiepileptic and psychotropic medications). Close clinical monitoring may be warranted.

Acute hyponatremia can lead to acute hyponatremic encephalopathy characterized by headache, nausea, seizures, lethargy and vomiting. Patients with brain edema are at particular risk of severe, irreversible and life-threatening brain injury. Patients at increased risk for developing complications of hyponatremia, such as hyponatremic encephalopathy include pediatric patients; women, in particular, premenopausal women; patients with hypoxemia; and in patients with underlying central nervous system disease [see *Use in Specific Populations (8.4, 8.5)*].

Avoid Dextrose Injection in patients with or at risk for hyponatremia. If use cannot be avoided, monitor serum sodium concentrations.

Rapid correction of hyponatremia is potentially dangerous with risk of serious neurologic complications. Brain adaptations reducing risk of cerebral edema make the brain vulnerable to injury when chronic hyponatremia is too rapidly corrected, which is known as osmotic demyelination syndrome (ODS). To avoid complications, monitor serum sodium and chloride concentrations, fluid status, acid-base balance, and signs of neurologic complications.

High volume infusion must be used with close monitoring in patients with cardiac or pulmonary failure, and in patients with non-osmotic vasopressin release (including SIADH), due to the risk of hospital-acquired hyponatremia

## **5.5 Electrolyte Imbalance and Fluid Overload**

Electrolyte deficits, particularly in serum potassium and phosphate, may occur during prolonged use of concentrated dextrose solutions.

Depending on the volume and rate of infusion, the intravenous administration of dextrose solutions can cause fluid and/or solute overloading resulting in dilution of serum electrolyte concentrations (including hypoosmotic hyponatremia, overhydration, congested states or pulmonary edema. The risk of dilutional states is inversely proportional to the electrolyte concentrations in the administered solution. The risk of solute overload causing congested states with peripheral and pulmonary edema is directly proportional to the electrolyte concentrations in the solution.

Avoid Dextrose Injection in patients with or at risk for fluid and/or solute overloading. If use cannot be avoided, monitor fluid balance, blood electrolyte levels, concentration of glucose, acid-base balance, correct fluid and electrolyte imbalances during prolonged parenteral therapy or whenever the condition of the patient or the rate of administration warrants such evaluation. Additional monitoring is recommended for patients with water and electrolyte disturbances that could be aggravated by increased glucose, insulin



administration and/or free water load.

Patients at increased risk for developing hyponatremic encephalopathy include pediatric patients; elderly patients, women, in particular premenopausal women; patients with hypoxemia; and patients with underlying CNS disease [see *Use in Specific Populations* (8.4, 8.5)].

## 5.6 Refeeding Syndrome

Refeeding severely undernourished patients may result in refeeding syndrome, characterized by the intracellular shift of potassium, phosphorus, and magnesium as the patient becomes anabolic. Thiamine deficiency and fluid retention may also develop. To prevent these complications, monitor severely undernourished patients and slowly increase nutrient intakes.

## 6 ADVERSE REACTIONS

The following adverse reactions associated with the use of Dextrose Injection were identified in clinical trials or post-marketing reports. Because these reactions were reported voluntarily from a population of uncertain size, it is not always possible to estimate their frequency, reliably, or to establish a causal relationship to drug exposure.

The following clinically significant adverse reactions are described elsewhere in the labeling:

- Hyperglycemia and hyperosmolar hyperglycemic state [see *Warnings and Precautions* (5.1)]
- Hypersensitivity reactions: anaphylaxis, pruritis, bronchospasm, cyanosis, angioedema, hypotension, pyrexia, chills, and rash [see *Warnings and Precautions* (5.2)]
- Infusion Site Reactions: infusion site phlebitis, infusion site erythema, vein damage and thrombosis [see *Warnings and Precautions* (5.3)]
- Hyponatremia and hyponatremic encephalopathy [see *Warnings and Precautions* (5.4)]
- Refeeding syndrome [see *Warnings and Precautions* (5.6)]
- Electrolyte imbalance, fluid overload and hypervolemia [see *Warnings and Precautions* (5.5)]

## 7 DRUG INTERACTIONS

### 7.1 Other Products that Affect Glycemic Control or Fluid and/or Electrolyte Balance

Dextrose Injection can affect glycemic control, vasopressin and fluid and/or electrolyte balance [see *Warnings and Precautions* (5.1, 5.4, 5.5)]. Monitor blood glucose concentrations, fluid balance, serum electrolyte concentrations and acid-base balance when using Dextrose Injection in patients treated with other substances that affect glycemic control, vasopressin or fluid and/or electrolyte balance.

## 8 USE IN SPECIFIC POPULATIONS

## **8.1 Pregnancy**

### Risk Summary

Appropriate administration of Dextrose Injection during pregnancy is not expected to cause adverse developmental outcomes, including congenital malformations. Animal reproduction studies have not been conducted with injectable dextrose solutions.

The estimated background risk of major birth defects and miscarriage for the indicated population is unknown. All pregnancies have a background risk of birth defect, loss, or other adverse outcomes. In the U.S. general population, the estimated background risk of major birth defects and miscarriage in clinically recognized pregnancies is 2 to 4% and 15 to 20%, respectively.

## **8.2 Lactation**

### Risk Summary

There are no data on the presence of dextrose in human milk, the effects on a breastfed infant, or the effects on milk production. The lack of clinical data during lactation precludes a clear determination of the risk of Dextrose Injection to an infant during lactation; therefore, the developmental and health benefits of breastfeeding should be considered along with the mother's clinical need for Dextrose Injection and any potential adverse effects on the breastfed infant from Dextrose Injection or from the underlying maternal condition.

## **8.4 Pediatric Use**

The safety profile of Dextrose Injection in pediatric patients is similar to adults.

Neonates, especially premature infants with low birth weight, are at increased risk of developing hypo- or hyperglycemia and therefore need close monitoring during treatment with intravenous glucose infusions to ensure adequate glycemic control in order to avoid potential long-term adverse effects.

Closely monitor plasma electrolyte concentrations in pediatric patients who may have impaired ability to regulate fluids and electrolytes. In very low birth weight infants, excessive or rapid administration of Dextrose Injection may result in increased serum osmolality and risk of intracerebral hemorrhage.

Children (including neonates and older children) are at increased risk of developing hyponatremia as well as for developing hyponatremic encephalopathy [see *Warnings and Precautions (5.4)*].

## **8.5 Geriatric Use**

Clinical studies of Dextrose Injection did not include sufficient numbers of subjects aged 65 and over to determine whether they respond differently from younger subjects. Elderly patients are at increased risk of developing hyponatremia as well as for developing hyponatremic encephalopathy [see *Warnings and Precautions (5.4)*]. Other reported clinical experience has not identified differences in responses between the elderly and younger patients. In general, dose selection for an elderly patient should be cautious, usually starting at the low end of the dosing range, reflecting the greater frequency of decreased hepatic, renal, or cardiac function, and of concomitant disease

or other drug therapy.

Dextrose is known to be substantially excreted by the kidney, and the risk of toxic reactions to this drug may be greater in patients with impaired renal function. Because elderly patients are more likely to have decreased renal function, care should be taken in dose selection, and it may be useful to monitor renal function.

## 10 OVERDOSAGE

An increased infusion rate of Dextrose Injection or administration of dextrose solutions can cause hyperglycemia, hyperosmolality, and adverse effects on water and electrolyte balance [see *Warnings and Precautions (5.1, 5.5)*].

Severe hyperglycemia and severe dilutional hyponatremia, and their complications, can be fatal. Discontinue infusion, reduce dose and institute appropriate corrective measures such as administration of exogenous insulin.

Discontinue infusion and institute appropriate corrective measures in the event of overhydration or solute overload during therapy, with particular attention to CNS, respiratory and cardiovascular systems.

If over-exposure occurs, call your Poison Control Center at 1-800-222-1222 for current information on the management of poisoning or overdose.

## 11 DESCRIPTION

Dextrose Injection, 5% USP is a clear, sterile, non-pyrogenic solution of Dextrose, USP in Water for Injection in a polyvinylchloride flexible plastic container for intravenous administration after admixture with a single dose powdered or liquid (up to 10 mL) drug vial [see *Dosage and Administration (2.1)*].

Flexible containers, designed to facilitate admixture, are available in 50 mL and 100 mL sizes. See Table 1 for the content and characteristics of this solution.

The solution contains no bacteriostatic, antimicrobial agent or added buffer and is intended only for use as a single-dose injection. The pH range is 4.0 (3.2 to 6.5).

Water can permeate from inside the container into the overwrap but not in amounts sufficient to affect the solution significantly.

**Table 1. Contents and Characteristics of Dextrose Injection 5%, USP**

<b>Strength</b>	<b>Fill Volume</b>	<b>Amount of Dextrose Hydrus per Container</b>	<b>kcal* per Container</b>	<b>mOsmol per liter</b>
Dextrose Injection 5%, USP (0.05 grams/mL)	100 mL Single Pack	5 grams	17	252
	50 mL Single Pack	2.5 grams	8.5	252

\* Caloric value calculated on the basis of 3.4 kcal/g of dextrose, hydrus

Dextrose, USP is chemically designated D-glucose, monohydrate ( $C_6H_{12}O_6 \cdot H_2O$ ), a hexose sugar freely soluble in water. The molecular weight of dextrose (D-glucose) monohydrate is 198.17. It has the following structural formula:

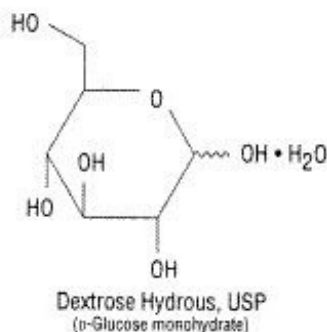

Water for Injection, USP is chemically designated  $H_2O$ .

Dextrose is derived from corn.

The **Mini-Bag Plus** Container System is a standard diluent container with an integral drug vial adaptor. It allows for drug admixture after connection to a single dose powdered or liquid (up to 10 mL) drug vial having a 13mm or 20mm closure. A breakaway seal in the tube between the vial adaptor and the container is broken to allow transfer of the diluent into the vial and reconstitution of a powdered or a liquid (up to 10mL) drug. The Mini-Bag Plus product mechanically prohibits the transfer of contaminants into and out of the system during and after docking, minimizing environmental and personal exposure. The reconstituted drug is then transferred from the vial into the container diluent and mixed to result in an infusion solution for delivery to the patient.

The VIAFLEX Plastic Container is fabricated from a specially formulated polyvinyl chloride (PL 146 Plastic). The amount of water that can permeate from inside the container into the overwrap is insufficient to affect the solution significantly. Solutions in contact with the plastic container can leach out certain of its chemical components in very small amounts within the expiration period, e.g., di-2-ethylhexyl phthalate (DEHP), up to 5 parts per million. However, the safety of the plastic has been confirmed in tests in animals according to USP biological tests for plastic containers as well as by tissue culture toxicity studies.

## 12 CLINICAL PHARMACOLOGY

### 12.1 Mechanism of Action

Dextrose oxidized to carbon dioxide and water, yielding energy.

## 16 HOW SUPPLIED/STORAGE AND HANDLING

Dextrose Injection 5%, USP is a clear, sterile solution of dextrose supplied in single-dose, flexible containers. The product is available as single packs (1 unit per overpouch). Table

2 lists single pack presentation compatible with vials with a 13 mm closure, and Table 3 lists single pack presentation compatible with vials with a 20 mm closure.

**Table 2. Presentations of Dextrose Injection Compatible with Vials with a 13 mm Closure**

<b>Product Description</b>	<b>Size</b>	<b>Vial Adaptor Size</b>	<b>Configuration</b>	<b>Code</b>	<b>NDC</b>
Dextrose Injection 5%, USP (0.05 grams/mL)	50 mL	13 mm	single pack	EZPB0036LF	0338-0170-01
	100 mL	13 mm	single pack	EZPB0037LF	0338-0172-01

**Table 3. Presentations of Dextrose Injection Compatible with Vials with a 20 mm Closure**

<b>Product Description</b>	<b>Size</b>	<b>Vial Adaptor Size</b>	<b>Configuration</b>	<b>Code</b>	<b>NDC</b>
Dextrose Injection 5%, USP (0.05 grams/mL)	50 mL	20 mm	single pack	EZPB0040LF	0338-0174-01
	100 mL	20 mm	single pack	EZPB0041LF	0338-0176-01

Do not remove container from the overwrap until intended for use.

Minimize exposure of Dextrose Injection to heat. Avoid excessive heat. Store at room temperature (25°C/77°F).

## **17 PATIENT COUNSELING INFORMATION**

Inform patients, caregivers, or home healthcare providers of the following risks of Dextrose Injection:

- Hyperglycemia and hyperosmolar hyperglycemic state  
Inform patients and their caregivers that administration of Dextrose Injection at a rate exceeding the patient's utilization rate may lead to hyperglycemia, coma, and death [see *Warnings and Precautions (5.1)*].
- Hypersensitivity reactions  
Inform patients and caregivers that Dextrose Injection may cause hypersensitivity reactions. If using Dextrose Injection at home, instruct patients or caregivers if a hypersensitivity reaction occurs, stop the infusion of Dextrose Injection immediately and seek medical attention [see *Warnings and Precautions (5.2)*].
- Vein damage and thrombosis  
Inform patients and caregivers that intravenous administration of Dextrose Injection into a peripheral vein may cause venous thrombophlebitis, which manifests as pain, erythema, tenderness, or a palpable cord [see *Warnings and Precautions (5.3)*].

- Hyponatremia  
In patients with or at risk for hyponatremia, inform the patient and caregivers that close monitoring of serum sodium may be warranted [see Warnings and Precautions (5.4)]
- Electrolyte imbalance and fluid overload  
For patients with decreased renal function, inform them or their caregivers that the patient may be at increased risk of electrolyte and fluid volume imbalance when Dextrose Injection is being administered [see Warnings and Precautions (5.5)].
- Refeeding syndrome  
If the patient is severely malnourished, inform patients and caregivers that administering Dextrose Injection may result in refeeding syndrome [see Warnings and Precautions (5.6)].
- Preparation and Administration Instructions  
If it is acceptable for a patient or caregiver to administer Dextrose Injection at home, then provide recommendations on how to prepare, add compatible additives (when appropriate), administer, and store Dextrose Injection [see Dosage and Administration (2.1, 2.2, 2.3)]

Manufactured by, Packed by, Distributed by:

**Baxter Healthcare Corporation**  
Deerfield, IL 60015 USA

CB-30-02-786

Baxter, Mini-Bag Plus, and Viaflex are trademarks of Baxter International Inc.

## PACKAGE/LABEL PRINCIPAL DISPLAY PANEL

**BREAK SEAL AND MIX BEFORE USE**



**BREAK SEAL AND MIX BEFORE USE**

**EZPB0036LF**  
**NDC 0338-0170-01**

**50 mL**

**5% Dextrose**  
**Injection USP**  
**MINI-BAG PLUS Single Dose Container**

**1 Symbol -**  
**13**  
**mm**  
**VIAL**

**FOR USE WITH 13mm VIAL**

Each 50 mL contains 2.5 g Dextrose  
Hydrous USP Sterile See prescribing  
information Additive compatibility  
consult pharmacist For intravenous use  
Do not administer simultaneously with blood  
Store at Room Temperature (25°C)  
Avoid Excessive Heat **Rx Only**

***Baxter Logo***  
**Baxter Healthcare Corporation**  
Deerfield IL 60015 USA  
Made in Ireland

CB-35-05-001 (1)

Lot  
Exp

Bar Code  
(01)0030330170012

**BREAK SEAL AND MIX BEFORE USE**



**BREAK SEAL AND MIX BEFORE USE**

**EZPB0040LF  
NDC 0338-0174-01**

**50 mL**

**5% Dextrose  
Injection USP  
MINI-BAG PLUS Single Dose Container**

**1 Symbol -  
20  
mm  
VIAL**

**FOR USE WITH 20mm VIAL**

Each 50 mL contains 2.5 g Dextrose  
Hydrous USP Sterile See prescribing  
information Additive compatibility  
consult pharmacist For intravenous use  
Do not administer simultaneously with blood  
Store at Room Temperature (25°C)  
Avoid Excessive Heat **Rx Only**

**BAXTER LOGO  
BAXTER HEALTHCARE CORPORATION  
DEERFIELD IL 60015 USA  
MADE IN IRELAND**

CB-35-05-002

Lot  
Exp



Bar Code  
(01)00303380174010

**BREAK SEAL AND MIX BEFORE USE**

EZPB0037LF NDC 0338-0172-01

**100 mL**

**5% Dextrose Injection USP**

MINI-BAG PLUS SINGLE DOSE CONTAINER

FOR USE WITH 13mm VIAL

EACH 100 mL CONTAINS 5 g DEXTROSE HYDROUS USP STERILE SEE PRESCRIBING INFORMATION ADDITIVE COMPATIBILITY CONSULT PHARMACIST FOR INTRAVENOUS USE DO NOT ADMINISTER SIMULTANEOUSLY WITH BLOOD STORE AT ROOM TEMPERATURE (25°C) AVOID EXCESSIVE HEAT Rx ONLY

**Baxter**  
BAXTER HEALTHCARE CORPORATION  
DEERFIELD IL 60015 USA  
MADE IN IRELAND  
CB-35-05-003 ①

LOT \_\_\_\_\_ EXP \_\_\_\_\_

**BREAK SEAL AND MIX BEFORE USE**

**EZPB0037LF**  
**NDC 0338-0172-01**

**100 mL**

**5% Dextrose**  
**Injection USP**  
**MINI-BAG PLUS Single Dose Container**

**1 Symbol -**

**13**  
**mm**  
**VIAL**

**FOR USE WITH 13mm VIAL**

Each 100 mL contains 5 g Dextrose Hydrus USP Sterile See prescribing information Additive compatibility consult pharmacist For intravenous use Do not administer simultaneously with blood Store at Room Temperature (25°C) Avoid Excessive Heat **Rx Only**

**BAXTER LOGO**  
**BAXTER HEALTHCARE CORPORATION**  
DEERFIELD IL 60015 USA  
MADE IN IRELAND

CB-35-05-003

Lot  
Exp

Bar Code  
(01)00303380172016

**BREAK SEAL AND MIX BEFORE USE**

EZPB0041LF NDC 0338-0176-01

**100 mL**

**5% Dextrose Injection USP**

MINI-BAG PLUS SINGLE DOSE CONTAINER

FOR USE WITH 20mm VIAL

EACH 100 mL CONTAINS 5 g DEXTROSE HYDROUS USP STERILE SEE PRESCRIBING INFORMATION ADDITIVE COMPATIBILITY CONSULT PHARMACIST FOR INTRAVENOUS USE DO NOT ADMINISTER SIMULTANEOUSLY WITH BLOOD STORE AT ROOM TEMPERATURE (25°C) AVOID EXCESSIVE HEAT Rx ONLY

**Baxter**  
BAXTER HEALTHCARE CORPORATION  
DEERFIELD IL 60015 USA  
MADE IN IRELAND

CB-35-05-004 ①

Lot Exp

**BREAK SEAL AND MIX BEFORE USE**

**EZPB0041LF**  
**NDC 0338-0176-01**

**100 mL**

**5% Dextrose**  
**Injection USP**  
**MINI-BAG PLUS Single Dose Container**

**1 Symbol -**  
**20**  
**mm**  
**VIAL**

**FOR USE WITH 20mm VIAL**

Each 100 mL contains 5 g Dextrose Hydrus USP Sterile See prescribing information Additive compatibility consult pharmacist For intravenous use Do not administer simultaneously with blood Store at Room Temperature (25°C) Avoid Excessive Heat **Rx Only**

**BAXTER LOGO**  
**BAXTER HEALTHCARE CORPORATION**  
DEERFIELD IL 60015 USA  
MADE IN IRELAND

CB-35-05-004

Lot  
Exp

Bar Code  
(01)00303380176014

## DEXTROSE

dextrose monohydrate injection

### Product Information

<b>Product Type</b>	HUMAN PRESCRIPTION DRUG	<b>Item Code (Source)</b>	NDC:0338-0170
<b>Route of Administration</b>	INTRAVENOUS		

### Active Ingredient/Active Moiety

Ingredient Name	Basis of Strength	Strength
<b>DEXTROSE MONOHYDRATE</b> (UNII: LX22YL083G) (ANHYDROUS DEXTROSE - UNII:5SL0G7R00K)	DEXTROSE MONOHYDRATE	2.5 g in 50 mL

### Inactive Ingredients

Ingredient Name	Strength
<b>WATER</b> (UNII: 059QF0KO0R)	

### Packaging

#	Item Code	Package Description	Marketing Start Date	Marketing End Date
1	NDC:0338-0170-01	30 in 1 CARTON	12/07/2022	
1		50 mL in 1 BAG; Type 0: Not a Combination Product		

### Marketing Information

Marketing Category	Application Number or Monograph Citation	Marketing Start Date	Marketing End Date
NDA	NDA020179	12/07/1992	

**DEXTROSE**

dextrose monohydrate injection

### Product Information

<b>Product Type</b>	HUMAN PRESCRIPTION DRUG	<b>Item Code (Source)</b>	NDC:0338-0174
<b>Route of Administration</b>	INTRAVENOUS		

### Active Ingredient/Active Moiety

<b>Ingredient Name</b>	<b>Basis of Strength</b>	<b>Strength</b>
<b>DEXTROSE MONOHYDRATE</b> (UNII: LX22YL083G) (ANHYDROUS DEXTROSE - UNII:5SL0G7R0OK)	DEXTROSE MONOHYDRATE	2.5 g in 50 mL

### Inactive Ingredients

<b>Ingredient Name</b>	<b>Strength</b>
<b>WATER</b> (UNII: 059QF0KO0R)	

### Packaging

<b>#</b>	<b>Item Code</b>	<b>Package Description</b>	<b>Marketing Start Date</b>	<b>Marketing End Date</b>
1	NDC:0338-0174-01	30 in 1 CARTON	12/07/2022	
1		50 mL in 1 BAG; Type 0: Not a Combination Product		

### Marketing Information

<b>Marketing Category</b>	<b>Application Number or Monograph Citation</b>	<b>Marketing Start Date</b>	<b>Marketing End Date</b>
NDA	NDA020179	12/07/1992	

## DEXTROSE

dextrose monohydrate injection

### Product Information

<b>Product Type</b>	HUMAN PRESCRIPTION DRUG	<b>Item Code (Source)</b>	NDC:0338-0172
<b>Route of Administration</b>	INTRAVENOUS		

### Active Ingredient/Active Moiety

<b>Ingredient Name</b>	<b>Basis of Strength</b>	<b>Strength</b>
<b>DEXTROSE MONOHYDRATE</b> (UNII: LX22YL083G) (ANHYDROUS DEXTROSE - UNII:5SL0G7R0OK)	DEXTROSE MONOHYDRATE	5 g in 100 mL

## Inactive Ingredients

Ingredient Name	Strength
<b>WATER</b> (UNII: 059QF0KO0R)	

## Packaging

#	Item Code	Package Description	Marketing Start Date	Marketing End Date
1	NDC:0338-0172-01	30 in 1 CARTON	12/07/2022	
1		100 mL in 1 BAG; Type 0: Not a Combination Product		

## Marketing Information

Marketing Category	Application Number or Monograph Citation	Marketing Start Date	Marketing End Date
NDA	NDA020179	12/07/1992	

## DEXTROSE

dextrose monohydrate injection

### Product Information

<b>Product Type</b>	HUMAN PRESCRIPTION DRUG	<b>Item Code (Source)</b>	NDC:0338-0176
<b>Route of Administration</b>	INTRAVENOUS		

### Active Ingredient/Active Moiety

Ingredient Name	Basis of Strength	Strength
<b>DEXTROSE MONOHYDRATE</b> (UNII: LX22YL083G) (ANHYDROUS DEXTROSE - UNII:5SL0G7R00K)	DEXTROSE MONOHYDRATE	5 g in 100 mL

## Inactive Ingredients

Ingredient Name	Strength
<b>WATER</b> (UNII: 059QF0KO0R)	

## Packaging

#	Item Code	Package Description	Marketing Start Date	Marketing End Date
1	NDC:0338-0176-01	30 in 1 CARTON	12/07/2022	
1		100 mL in 1 BAG; Type 0: Not a Combination Product		

## Marketing Information

Marketing Category	Application Number or Monograph Citation	Marketing Start Date	Marketing End Date
NDA	NDA020179	12/07/1992	

**Labeler** - Baxter Healthcare Corporation (005083209)

## Establishment

Name	Address	ID/FEI	Business Operations
Baxter Healthcare S.A.		988899845	ANALYSIS(0338-0170, 0338-0172, 0338-0174, 0338-0176) , LABEL(0338-0170, 0338-0172, 0338-0174, 0338-0176) , MANUFACTURE(0338-0170, 0338-0172, 0338-0174, 0338-0176) , PACK(0338-0170, 0338-0172, 0338-0174, 0338-0176) , STERILIZE(0338-0170, 0338-0172, 0338-0174, 0338-0176)

## Establishment

Name	Address	ID/FEI	Business Operations
Baxter Healthcare Corporation		091171389	ANALYSIS(0338-0170, 0338-0174, 0338-0172, 0338-0176)

## Establishment

Name	Address	ID/FEI	Business Operations
Baxter Healthcare Corporation		189326168	ANALYSIS(0338-0170, 0338-0174, 0338-0172, 0338-0176)

## Establishment

Name	Address	ID/FEI	Business Operations
Baxter Healthcare Corporation		194684502	ANALYSIS(0338-0170, 0338-0174, 0338-0172, 0338-0176)

Revised: 12/2022

Baxter Healthcare Corporation