

HIGHLIGHTS OF PRESCRIBING INFORMATION

These highlights do not include all the information needed to use MYOVIEW safely and effectively. See full prescribing information for MYOVIEW.

MYOVIEW (Kit for the preparation of technetium Tc99m tetrofosmin injection) for intravenous use
Initial U.S. Approval: 1996

INDICATIONS AND USAGE

MYOVIEW is a kit for the preparation of technetium Tc99m tetrofosmin for injection. Technetium Tc99m tetrofosmin injection is a radioactive diagnostic agent indicated for the following:

- Myocardial perfusion imaging under rest and/or exercise or pharmacologic stress conditions to delineate regions of reversible myocardial ischemia or infarcted myocardium in patients with known or suspected coronary artery disease (1.1)
- Assessment of left ventricular function (left ventricular ejection fraction and wall motion) in patients with known or suspected heart disease (1.2)

DOSAGE AND ADMINISTRATION

- Use appropriate radiation safety measures and aseptic technique during preparation and handling (2.1, 2.3)
- The recommended dose range for MYOVIEW for rest or stress imaging is 185 to 1,221 megabecquerels (MBq) [5 to 33 millicuries (mCi)] by intravenous administration (2.2)
- When rest and stress injections are administered on the same day, the first dose should be 185 to 444 MBq (5 to 12 mCi) followed by the second dose of 555 to 1,221 MBq (15 to 33 mCi) given approximately 1 to 4 hours later (2.2)
- The recommended dose range for MYOVIEW for ventricular function assessment is 185 to 1,221 MBq (5 to 33 mCi) as an intravenous injection (2.2)
- See Full Prescribing Information for instructions for preparation and determination of radiochemical purity (2.4, 2.5)
- Imaging may begin 15 minutes following administration of the agent (2.6)

DOSAGE FORMS AND STRENGTHS

Kit for preparation injection: lyophilized powder containing 0.23 mg tetrofosmin in a multiple-dose vial after radiolabeling with Tc99m eluate, clear solution not exceeding 1,110 MBq/mL (30 mCi/mL). (3)

CONTRAINDICATIONS

- None (4)

WARNINGS AND PRECAUTIONS

- Risk with exercise or pharmacologic stress:
 - Continuous cardiac monitoring should be performed in studying patients with known or suspected coronary artery disease (5.1)
 - When pharmacologic stress is selected as an alternative to exercise, perform the procedure in accordance with the pharmacologic stress agent's prescribing information (5.1)
- Appropriate safety measures should be used to minimize radiation exposure to clinical personnel and to the patient consistent with proper patient management (2.1, 5.2)

ADVERSE REACTIONS

Most common adverse reactions (incidence < 1%) after MYOVIEW injection: Cardiovascular: angina, hypertension, torsades de pointes. Gastrointestinal: vomiting, abdominal discomfort. Hypersensitivity: cutaneous allergy, hypotension, dyspnea. Special Senses: metallic taste, burning of the mouth, smell alteration. (6.1)

To report SUSPECTED ADVERSE REACTIONS, contact GE Healthcare at 1-800-654-0118 or FDA at 1-800-FDA-1088 or www.fda.gov/medwatch.

USE IN SPECIFIC POPULATIONS

- Advise the pregnant woman of the potential risk to the fetus based on the radiation dose from technetium Tc99m and the gestational timing of exposure (8.1)
- Lactation - A lactating woman should pump and discard breastmilk for 60 hours after technetium Tc99m tetrofosmin administration (8.2)

See 17 for PATIENT COUNSELING INFORMATION

Revised: 12/2022

FULL PRESCRIBING INFORMATION: CONTENTS*

1 INDICATIONS AND USAGE

- 1.1 Myocardial Perfusion Imaging
- 1.2 Ventricular Function Imaging

2 DOSAGE AND ADMINISTRATION

- 2.1 Radiation Safety – Drug Handling
- 2.2 Recommended Dosage
- 2.3 Administration Instructions
- 2.4 Instructions for Preparation
- 2.5 Determination of Radiochemical Purity
- 2.6 Imaging Instructions
- 2.7 Radiation Dosimetry

3 DOSAGE FORMS AND STRENGTHS

4 CONTRAINDICATIONS

5 WARNINGS AND PRECAUTIONS

- 5.1 Risks Associated with Exercise and Pharmacologic Stress
- 5.2 Radiation Risks
- 5.3 Hypersensitivity Reactions

6 ADVERSE REACTIONS

- 6.1 Clinical Trials Experience
- 6.2 Postmarketing Experience

8 USE IN SPECIFIC POPULATIONS

- 8.1 Pregnancy
- 8.2 Lactation
- 8.4 Pediatric Use
- 8.5 Geriatric Use

11 DESCRIPTION

- 11.1 Chemical Characteristics
- 11.2 Physical Characteristics
- 11.3 External Radiation

12 CLINICAL PHARMACOLOGY

- 12.1 Mechanism of Action
- 12.2 Pharmacodynamics
- 12.3 Pharmacokinetics

13 NONCLINICAL TOXICOLOGY

- 13.1 Carcinogenesis, Mutagenesis, Impairment of Fertility

14 CLINICAL STUDIES

- 14.1 Exercise/Resting Myocardial Perfusion Imaging Studies
- 14.2 Pharmacological Stress Myocardial Perfusion Imaging Studies
- 14.3 Ventricular Function Stress Myocardial Perfusion Imaging Studies

16 HOW SUPPLIED/STORAGE AND HANDLING

- 16.1 How Supplied
- 16.2 Storage and Handling

17 PATIENT COUNSELING INFORMATION

* Sections or subsections omitted from the full prescribing information are not listed.

FULL PRESCRIBING INFORMATION

1 INDICATIONS AND USAGE

1.1 Myocardial Perfusion Imaging

Myocardial perfusion imaging under rest and/or exercise or pharmacologic stress conditions to delineate regions of reversible myocardial ischemia or infarcted myocardium in patients with known or suspected coronary artery disease.

1.2 Ventricular Function Imaging

MYOVIEW is indicated for assessment of left ventricular function (left ventricular ejection fraction and wall motion) in patients with known or suspected heart disease.

2 DOSAGE AND ADMINISTRATION

2.1 Radiation Safety – Drug Handling

Technetium Tc99m tetrofosmin is a radioactive drug and should be handled with appropriate safety measures to minimize radiation exposure during administration [*see Warnings and Precautions (5.2)*]. Use waterproof gloves and effective shielding, including syringe shields, when preparing and administering technetium Tc99m tetrofosmin injection.

2.2 Recommended Dosage

- The recommended dose range for MYOVIEW is 185 to 1,221 megabecquerels (MBq) (5 to 33 millicuries (mCi)) by intravenous administration for rest and stress imaging.
- When rest and stress intravenous injections are administered on the same day, the first dose should be 185 to 444 MBq (5 to 12 mCi) and followed by the second dose of 555 to 1,221 MBq (15 to 33 mCi) given approximately 1 to 4 hours later.
- The recommended dose range for MYOVIEW is 185 to 1,221 MBq (5 to 33 millicuries (mCi)) by intravenous administration as an intravenous injection for ventricular function assessment.

2.3 Administration Instructions

- Use aseptic technique for all drug preparation and handling.
- Measure the dose in a suitable radioactivity calibration system immediately prior to intravenous administration.
- Visually inspect the drug for particulate matter and discoloration prior to administration. Do not use or administer the drug if there is evidence of particulate matter or discoloration.
- Instruct patients to remain hydrated and void frequently following administration to decrease radiation exposure [*see Warnings and Precautions (5.2)*].

2.4 Instructions for Preparation

The following steps as detailed are critical and should be followed to ensure adequate preparation of the product.

1. The technetium Tc99m labeling reaction involved in the preparation of MYOVIEW Injection depends on maintaining tin in the divalent (reduced) state. Any oxidant present in the sodium pertechnetate Tc99m used may adversely affect the quality of the preparation. Sodium pertechnetate Tc99m containing oxidants should not be used for the preparation of the labeled product.
2. Elute the technetium generator with sodium chloride injection, USP.
3. Insert a venting needle (standard 18 to 26 gauge needle, not provided) through the rubberseptum of the shielded vial containing the lyophilized powder.
4. Inject no more than 8.8 GBq (240 mCi) of technetium Tc99m generator eluate into the shielded vial.
5. Use sodium chloride injection, USP as a diluent. Inject 4 to 8 mL to achieve a radioactive concentration no greater than 1.1 GBq/mL (30 mCi/mL) in the vial.
6. Before removing the syringe from the vial, withdraw 2 mL of gas from above the solution.
7. Remove the venting needle.
8. Mix gently for 10 seconds to ensure complete dissolution of the powder.
9. Incubate at room temperature for 15 minutes.
10. Assay the total activity using a suitably calibrated instrument; complete the user radiation label and attach it to the vial.
11. Measure the pH of the prepared injection and verify it is between 7.5 to 9.0.
12. Store the radiolabeled MYOVIEW vial at 2° to 25°C (36° to 77°F) and use radiolabeled injection within 12 hours of preparation.

2.5 Determination of Radiochemical Purity

Obtain the following materials:

1. SA TLC strip (2 cm × 20 cm), do not heat activate
2. Ascending chromatography tank and cover
3. Mixture of acetone and dichloromethane (65:35% v/v), prepare freshly
4. Syringe (1 mL) with needle (22 to 25 gauge)
5. Suitable counting equipment

Perform the following:

1. Pour the 65:35% v/v acetone:dichloromethane mixture into the chromatography tank to a depth of 1 cm and cover the tank to allow the solvent vapor to equilibrate.
2. Mark SA TLC strip with a pencil line at 3 cm from the bottom and, using an ink markerpen, at 15 cm from the pencil line. The pencil line indicates the origin where the sample is to be applied and movement of color from the ink line will indicate the position of the solvent front when upward elution should be stopped.
3. Mark cutting positions at 3.75 cm and 12 cm above the origin [retention value (R_f) 0.25 and 0.8 respectively] in pencil.
4. Using a 1 mL syringe and needle, apply a 10 microliter sample of the prepared injection at the origin of the strip. Do not allow the spot to dry. Place the strip in the chromatography tank immediately and replace the cover. Ensure that the strip is not adhering to the walls of the tank.

Note: A 10 microliter sample will produce a spot with a diameter of approximately 10 mm. Different sample volumes have been shown to give unreliable radiochemical purity values.

- When the solvent reaches the ink line, remove the strip from the tank and allow it to dry.
- Cut the strip into 3 pieces at the marked cutting positions and measure the activity on each using suitable counting equipment. Ensure similar counting geometry for each piece and minimize equipment dead time losses. Note: Free Tc99m pertechnetate runs to the top piece of the strip. MYOVIEW runs to the center piece of the strip. Reduced hydrolyzed Tc99m and any hydrophilic complex impurities remain at the origin in the bottom piece of the strip.

TLC strip diagram

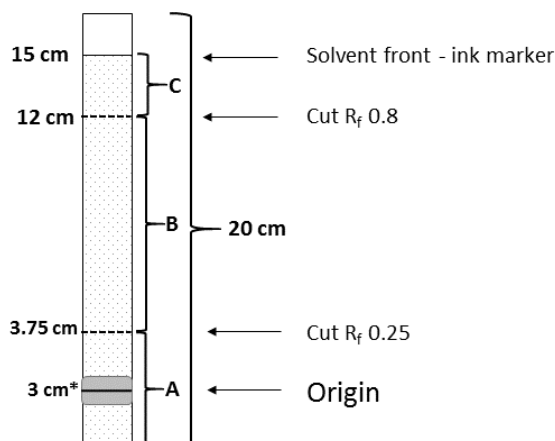

*Measured from plate edge; all other measurements are from origin.
Count radioactivity in sections A, B, and C separately.
Percent radiochemical purity = $100\% \times B / (A + B + C)$.

- Calculate the radiochemical purity from:

$$\% \text{ Tc99m tetrofosmin} = \frac{\text{Activity of Center Piece (B)}}{\text{Total Activity of Three Pieces (A+B+C)}} \times 100$$

- Do not use material if the radiochemical purity is less than 90%.

2.6 Imaging Instructions

- Imaging may begin 15 minutes after injection.
- The recommended imaging duration of the scan may vary depending on dose, imaging acquisition, and reconstruction parameters.

2.7 Radiation Dosimetry

Radiation absorbed dose per unit activity of the agent injected intravenously in an adult of average weight (74 kg) is estimated in Table 1 for exercise and resting conditions. The values listed correspond to a 3.5-hour voiding period for excretion from the urinary bladder.

Table 1 Estimated Radiation Absorbed Dose (Technetium Tc99m Tetrofosmin Injection)

Target organ	Radiation absorbed dose per unit activity injected intravenously			
	Exercise		Rest	
	rad/mCi	microGy/MBq	rad/mCi	microGy/MBq
Gall bladder wall	0.10	27	0.13	36
Upper large intestine	0.074	20	0.10	27
Lower large intestine	0.055	15	0.074	20
Bladder wall	0.052	14	0.063	17
Small intestine	0.041	11	0.056	15
Kidney	0.037	10	0.048	13
Salivary glands	0.030	8.0	0.043	12
Ovaries	0.029	7.7	0.033	8.8
Uterus	0.026	7.0	0.029	7.8
Bone surface	0.023	6.3	0.021	5.8
Thyroid	0.017	4.7	0.020	5.5
Pancreas	0.019	5.0	0.018	4.9
Heart wall	0.019	5.2	0.017	4.7
Stomach	0.017	4.6	0.017	4.5
Adrenals	0.016	4.4	0.016	4.2
Liver	0.012	3.3	0.015	4.0
Spleen	0.015	4.1	0.014	3.9
Red marrow	0.014	3.9	0.014	3.8
Muscle	0.013	3.5	0.012	3.3
Testes	0.013	3.4	0.011	3.1
Thymus	0.012	3.3	0.010	2.8
Esophagus	0.012	3.3	0.010	2.8
Lungs	0.012	3.2	0.010	2.8
Brain	0.010	2.7	0.0085	2.3
Skin	0.0081	2.2	0.0074	2.0
Breasts	0.0085	2.3	0.0074	2.0
Remaining organs	0.014	3.8	0.014	3.8
Effective dose per unit activity	0.026 rem/mCi	6.9 microSv/MBq	0.030 rem/mCi	8.0 microSv/MBq

3 DOSAGE FORMS AND STRENGTHS

Kit for the preparation of technetium Tc99m tetrofosmin injection: 10 mL multiple-dose, clear, glass vial with a white sterile, non-pyrogenic, lyophilized powder of 0.23 mg tetrofosmin, 0.03 mg stannous chloride dihydrate, 0.32 disodium sulphosalicylate, 1 mg sodium D-gluconate and 1.8 mg sodium hydrogen carbonate.

Following radiolabeling with the Tc99m eluate, MYOVIEW is a clear solution not exceeding 1,110 MBq/mL (30 mCi/mL) of Tc99m.

4 CONTRAINDICATIONS

None.

5 WARNINGS AND PRECAUTIONS

5.1 Risks Associated with Exercise or Pharmacologic Stress

Patients evaluated with exercise or pharmacologic stress may experience serious adverse reactions such as myocardial infarction, arrhythmia, hypotension, bronchoconstriction, and cerebrovascular reactions such as headache, paraesthesias, convulsions, somnolence and cerebrovascular accident, including hemorrhage. Perform stress testing in the setting where cardiac resuscitation equipment and trained staff are readily available. When pharmacologic stress is selected as an alternative to exercise, perform the procedure in accordance with the pharmacologic stress agent's prescribing information.

5.2 Radiation Risks

Technetium Tc99m contributes to a patient's overall long-term cumulative radiation exposure. Long-term cumulative radiation exposure is associated with an increased risk of cancer. Ensure safe handling and preparation radiolabeling procedures to protect patients and health care workers from unintentional radiation exposure. Encourage adequate hydration; instruct patients to void when the examination is completed and as often thereafter as possible [see *Dosage and Administration (2.1) and (2.3)*].

5.3 Hypersensitivity Reactions

Hypersensitivity reactions including anaphylaxis, dyspnea, bronchospasm, throat tightness, coughing, tachycardia, chest pain, hypotension, abdominal pain, and cutaneous reactions (rash, urticaria, pruritus, erythema, and swelling or angioedema) have been observed after the administration of MYOVIEW. Always have cardiopulmonary resuscitation equipment and personnel available and monitor all patients for hypersensitivity reactions.

6 ADVERSE REACTIONS

The following clinically significant adverse reactions are described elsewhere in the labeling:

- Hypersensitivity Reactions [see *Warnings and Precautions (5.3)*]

6.1 Clinical Trials Experience

Because clinical trials are conducted under widely varying conditions, adverse reaction rates observed in the clinical trials of MYOVIEW cannot be directly compared to rates in the clinical trials of another drug and may not reflect the rates observed in practice.

Adverse reactions were evaluated in clinical studies (using an exercise/rest protocol) of 764 adults (511 men and 253 women) with a mean age of 58.7 years (range 29 to 94 years). The subjects received a mean dose of 285 MBq (7.7 mCi) on the first injection and 829 MBq (22.4 mCi) on the second injection of MYOVIEW.

After MYOVIEW injection, angina occurred in 4 subjects, ventricular tachycardia in 1 subject, and respiratory arrest in 1 subject.

The following reactions were noted in less than 1% of subjects:

Cardiovascular: angina, hypertension, torsades de pointes.

Gastrointestinal: vomiting, abdominal discomfort.

Hypersensitivity: cutaneous allergy, hypotension, dyspnea.

Special Senses: metallic taste, burning of the mouth, smell alteration.

In four studies, 438 adults (232 men and 205 women; gender was not recorded for one subject) with a mean age of 65 years (range 27 to 97 years) received a single pharmacologic stress agent. The subjects received a mean dose of 7 to 8 mCi on the rest/first injection and 22 to 34 mCi on the stress/second injection. Among the 438 subjects, 319 subjects (73%) experienced an adverse reaction. Reactions occurring in $\geq 1\%$ of the subjects included angina (39%), flushing (36%), dyspnea (28%), headache (14%), abdominal pain (11%), dizziness (7%), palpitations (2%), nausea (2%), hypotension (1%) and pain (1%). Events occurring in $< 1\%$ include cough, arrhythmia, bronchospasm, ECG abnormalities, hypertension, vomiting and asthenia.

6.2 Postmarketing Experience

The following adverse reactions have been identified during post approval use of MYOVIEW. Because these reactions are reported voluntarily from a population of uncertain size, it is not always possible to reliably estimate their frequency or establish a causal relationship to drug exposure.

The most common adverse reactions reported included: rash, urticaria, abnormal vision, hypersensitivity reactions, and fever.

8 USE IN SPECIFIC POPULATIONS

8.1 Pregnancy

Risk Summary

There are no data with technetium Tc99m tetrofosmin use in pregnant women to inform any drug associated risks. Animal reproduction studies with technetium Tc99m tetrofosmin have not been conducted. However, all radiopharmaceuticals have the potential to cause fetal harm depending on the fetal stage of development and the magnitude of the radiation dose. If considering technetium Tc99m tetrofosmin administration to a pregnant woman advise the pregnant woman of risk to the fetus.

The estimated background risk of major birth defects and miscarriage for the indicated population is unknown. All pregnancies have a background risk of birth defect, loss, or other adverse outcomes. In the U.S. general population, the estimated background risk of major birth defects and miscarriage in clinically recognized pregnancies is 2 to 4% and 15 to 20%, respectively.

8.2 Lactation

Risk Summary

Technetium Tc99m tetrofosmin is present in human milk in small amounts (<1% of maternal dose). There are no data available regarding the effects of technetium Tc99m tetrofosmin on the breastfed infant or on milk production. The developmental and health benefits of breastfeeding should be considered along with the mother's clinical need for MYOVIEW and any potential adverse effects on the breastfed child from MYOVIEW or from the underlying maternal condition.

Clinical Considerations

To decrease radiation exposure to the breastfed infant, advise a lactating woman to pump and discard breast milk for 60 hours (10 half-lives) after technetium Tc99m tetrofosmin administration.

8.4 Pediatric Use

Safety and effectiveness in pediatric patients have not been established.

8.5 Geriatric Use

Of 2,300 subjects in clinical studies of MYOVIEW, 1,053 (46%) were 65 or older and 270 (12%) were 75 or older. No overall differences in safety were observed between these subjects and younger subjects, and other reported clinical experience has not identified differences in responses between elderly and younger patients, but greater sensitivity of some older individuals cannot be ruled out.

11 DESCRIPTION

11.1 Chemical Characteristics

MYOVIEW is a kit for the preparation of technetium Tc99m tetrofosmin injection for intravenous use. Technetium Tc99m tetrofosmin is a radioactive diagnostic agent. Each multiple-dose 10 mL glass vial contains a sterile, non-pyrogenic, lyophilized powder of 0.23 mg tetrofosmin [6,9-bis(2-ethoxyethyl)-3,12-dioxo-6,9-diphosphatetradecane], 0.03 mg stannous chloride dihydrate, (minimum stannous tin 0.015 mg; total stannous and stannic tin 0.0522 mg) 0.32 mg disodium sulphosalicylate, 1 mg sodium D-gluconate, and 1.8 mg sodium hydrogen carbonate. The lyophilized powder is sealed under a nitrogen atmosphere with a rubber closure. The product contains no antimicrobial preservative. The chemical formula of tetrofosmin is $C_{18}H_{40}O_4P_2$ with the following structural formula:

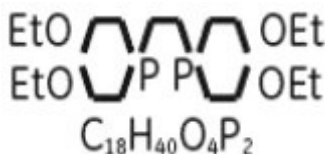

When sterile, pyrogen-free sodium pertechnetate Tc99m in isotonic saline is added to the vial, a Tc99m complex of tetrofosmin is formed. The radiolabeled product is a clear solution and the pH is in the range of 7.5 to 9.0.

11.2 Physical Characteristics

Technetium Tc99m decays by isomeric transition with a physical half-life of 6 hours. Photons that are useful for imaging studies are listed in Table 2.

Table 2 Principal radiation emission data - technetium Tc99m

Radiation	Mean % disintegration	Mean energy (keV)
Gamma 2	88.5	140.5

11.3 External Radiation

The air-kerma-rate (exposure-rate) constant for technetium Tc99m is $5.23 \text{ m}^2 \cdot \text{pGy} \cdot (\text{MBq})^{-1} \cdot \text{s}^{-1}$ [$0.795 \text{ cm}^2 \cdot \text{R} \cdot (\text{mCi})^{-1} \cdot \text{h}^{-1}$].

A range of values for the relative radiation attenuation by various thicknesses of Pb shielding is shown in Table 3. For example, the use of 3 mm thick Pb will decrease the external radiation exposure by a factor of approximately 1,000.

Table 3 Radiation attenuation by lead shielding

Shield thickness (Pb) mm	Factor of attenuation
0.25	0.5
1	10^{-1}
2	10^{-2}
3	10^{-3}
4	10^{-4}
5	10^{-5}

To correct for physical decay of this radionuclide, the fractions that remain at selected intervals relative to the time of calibration are shown in Table 4.

Table 4 Physical decay chart - Tc99m half-life 6 hours

Hours	Fraction Remaining	Hours	Fraction Remaining
0*	1.000	7	0.446
1	0.891	8	0.397
2	0.794	9	0.354
3	0.707	10	0.315
4	0.630	11	0.281
5	0.562	12	0.250
6	0.500	24	0.063

*Calibration time (time of preparation)

12 CLINICAL PHARMACOLOGY

12.1 Mechanism of Action

Technetium ($^{99\text{m}}\text{Tc}$) tetrofosmin is a lipophilic, cationic complex which diffuses passively through the cell membrane and is locally retained actively due to the presence of intact mitochondria reflecting the presence of viable cells. After intravenous injection, it is distributed within the myocardium according to myocardial perfusion and viability.

12.2 Pharmacodynamics

The relationship between Tc99m tetrofosmin plasma concentrations and successful imaging has not been explored in clinical trials.

12.3 Pharmacokinetics

Uptake in the myocardium is dependent on coronary flow and reaches a maximum of 1.2% of the injected dose (i.d.) at 5 minutes and 1% of the i.d. at 2 hours, respectively. Background activities in the blood, liver and lung were less than 5% of the administered activity in whole blood at 10 minutes post-injection, less than 4.5% i.d., after 60 minutes, and less than 2% i.d. after 30 minutes.

Elimination

Approximately 66% of the injected activity is excreted within 48 hours post-injection, with approximately 40% excreted in the urine and 26% in the feces.

13 NONCLINICAL TOXICOLOGY

13.1 Carcinogenesis, Mutagenesis, Impairment of Fertility

Studies have not been conducted to evaluate carcinogenic potential or effects on fertility. Tetrofosmin sulphosalicylate was not mutagenic *in vitro* in the Ames test, mouse lymphoma, or human lymphocyte tests, nor was it clastogenic *in vivo* in the mouse micronucleus test.

14 CLINICAL STUDIES

14.1 Exercise/Resting Myocardial Perfusion Imaging Studies

A total of 252 subjects with ischemic heart disease or atypical chest pain were studied in two open-label, multi-center, clinical studies (study a and study b). Of these 252 subjects there were 212 (84%) males and 40 (16%) females with a mean age of 60.5 years (range 33.7 to 82.4 years).

All subjects had exercise and rest planar imaging with MYOVIEW and thallium-201; 191 (76%) subjects also had single photon emission computed tomography (SPECT) imaging. At peak exercise, maximum heart rate achieved and peak systolic blood pressure were comparable after MYOVIEW and thallium-201 exercise studies. The MYOVIEW and thallium-201 images were separated by a mean of 5.1 days (1 to 14 days before or 2 to 14 days after MYOVIEW). For MYOVIEW imaging, each subject received 185 to 296 MBq (5 to 8 mCi) Tc99m tetrofosmin at peak exercise and 555 to 888 MBq (15 to 24 mCi) Tc99m tetrofosmin at rest approximately 4 hours later. For thallium-201 imaging, subjects received thallium-201 55.5 to 74 MBq (1.5 to 2 mCi) at peak exercise.

The images were evaluated for the quality of the image (excellent, good or poor) and the diagnosis (with scores of 0 = normal, 1 = ischemia, 2 = infarct, 3 = mixed infarct and ischemia). The primary outcome variable was the percentage of correct diagnoses in comparison to the final clinical diagnosis. All planar images were blindly read; SPECT images were evaluated by the unblinded investigator. The results for each blinded reader are noted in Table 5.

Table 5 Overall Diagnostic Outcome

Diagnosis	Study	Thallium 201		MYOVIEW	
		Reader 1	Reader 2	Reader 1	Reader 2
		% (95% CI)	% (95% CI)	% (95% CI)	% (95% CI)
Ischemia	a	77.7 (68.8, 85.0)	75.0 (65.9, 82.7)	66.3 (56.7, 75.1)	63.6 (53.9, 72.6)
	b	75.6 (66.9, 83.0)	68.9 (59.8, 77.1)	66.4 (57.2, 74.8)	66.4 (57.2, 74.8)
Infarct	a	75.9 (66.9, 83.5)	75.0 (65.9, 82.7)	74.5 (65.4, 82.4)	75.5 (66.3, 83.2)
	b	70.6 (61.5, 78.6)	69.7 (60.7, 77.8)	73.1 (64.2, 80.8)	68.1 (58.9, 76.3)

14.2 Pharmacological Stress Myocardial Perfusion Imaging Studies

MYOVIEW imaging after pharmacologic stress was evaluated in two studies in subjects with known or suspected coronary artery disease (CAD). Three blinded reads were obtained for 57 subjects (45 male [79%], 12 female [21%]; mean age 60.1 years) all of whom had angiography. Subject level analyses were based on the finding of SPECT myocardial perfusion abnormalities in patients with angiographically confirmed disease. Subject level sensitivities for MYOVIEW ranged from 68 to 83% and subject level specificities ranged from 45 to 82% across readers and studies.

14.3 Ventricular Function Stress Myocardial Perfusion Imaging Studies

Two open-label, multicenter, identically designed, blinded image read studies were conducted to assess left ventricular function using MYOVIEW ECG gated SPECT (GSPECT) myocardial perfusion imaging. A total of 329 subjects (216 male [65.7%], 113 female [34.3%]); mean age of 60.4 years) with known or suspected heart disease or requiring ventricular function assessments were dosed with MYOVIEW. Of these, 297 were considered evaluable. MYOVIEW was administered at rest and at peak stress using either a one-day or a 2-day dosing protocol.

For both studies, all subjects' stress GSPECT exams were compared to the reference exam of radionuclide ventriculography with Tc99m labeled RBCs (multiple gated acquisition [MUGA]), performed 1 to 5 days after the second MYOVIEW injection. All subjects' GSPECT exams were assessed by 3 independent blinded readers per study. The MUGA exams were evaluated by an independent consensus panel composed of 3 blinded readers. Subject level assessments were based upon discrimination between normal and abnormal values for LVEF (LVEF \geq 50% was considered normal) and normal and abnormal wall motion as judged visually. Sensitivity and specificity of LVEF determinations ranged from 81% to 88% and 76% to 85% respectively across studies and readers. Sensitivity and specificity of wall motion determinations ranged from 80% to 92% and 68% to 86% respectively across studies and readers.

16 HOW SUPPLIED/STORAGE AND HANDLING

16.1 How supplied

Five (5) multiple-dose kits, each containing a 10 mL glass vial with a sterile, non-pyrogenic, lyophilized powder containing 0.23 mg tetrofosmin, 0.03 mg stannous chloride dihydrate, 0.32 mg disodium sulphosalicylate, 1 mg sodium D-gluconate, 1.8 mg sodium hydrogen carbonate.

NDC 17156-024-05

The radionuclide is not part of the kit. Before radiolabeling with Tc99m, the contents of the kit are not radioactive.

16.2 Storage and Handling

Store the kit at 2° to 8°C (36° to 46°F), protected from light.

Store the radiolabeled vial at 2° to 25°C (36° to 77°F), using appropriate radiation shielding. Use within 12 hours of preparation.

This reagent kit is approved for use by persons under license by the Nuclear Regulatory Commission or the relevant regulatory authority of an Agreement State; store and dispose of technetium Tc99m tetrofosmin in accordance with these regulations.

17 PATIENT COUNSELING INFORMATION

- Instruct patients to remain hydrated and void frequently following administration to decrease radiation exposure.
- Advise a lactating woman to pump and discard breast milk for 60 hours (10 half-lives) after technetium Tc99m tetrofosmin administration to decrease radiation exposure to the breastfed infant.

Manufactured by:
GE Healthcare AS
Oslo, Norway

Distributed by:
GE Healthcare
Medi-Physics, Inc.
Arlington Heights, IL 60004

MYOVIEW is a trademark of GE Healthcare

GE and the GE Monogram are trademarks of General Electric Company.

© 2022 General Electric Company - All rights reserved.

HIGHLIGHTS OF PRESCRIBING INFORMATION

These highlights do not include all the information needed to use MYOVIEW 30 mL safely and effectively. See full prescribing information for MYOVIEW 30 mL.

MYOVIEW 30 mL (Kit for the preparation of technetium Tc99m tetrofosmin injection) for intravenous use
Initial U.S. Approval: 1996

INDICATIONS AND USAGE

MYOVIEW 30 mL is a kit for the preparation of technetium Tc99m tetrofosmin for injection. Technetium Tc99m tetrofosmin injection is a radioactive diagnostic agent indicated for the following:

- Myocardial perfusion imaging under rest and/or exercise or pharmacologic stress conditions to delineate regions of reversible myocardial ischemia or infarcted myocardium in patients with known or suspected coronary artery disease (1.1)
- Assessment of left ventricular function (left ventricular ejection fraction and wall motion) in patients with known or suspected heart disease (1.2)

DOSAGE AND ADMINISTRATION

- Use appropriate radiation safety measures and aseptic technique during preparation and handling (2.1, 2.3)
- The recommended dose range for MYOVIEW for rest or stress imaging is 185 to 1,221 megabecquerels (MBq) [5 to 33 millicuries (mCi)] by intravenous administration (2.2)
- When rest and stress injections are administered on the same day, the first dose should be 185 to 444 MBq (5 to 12 mCi) followed by the second dose of 555 to 1,221 MBq (15 to 33 mCi) given approximately 1 to 4 hours later (2.2)
- The recommended dose range for MYOVIEW for ventricular function assessment is 185 to 1,221 MBq (5 to 33 mCi) as an intravenous injection (2.2)
- See Full Prescribing Information for instructions for preparation and determination of radiochemical purity (2.4, 2.5)
- Imaging may begin 15 minutes following administration of the agent (2.6)

DOSAGE FORMS AND STRENGTHS

Kit for preparation injection: lyophilized powder containing 1.38 mg tetrofosmin in a multiple-dose vial after radiolabeling with Tc99m eluate, clear solution not exceeding 2,960 MBq/mL (80 mCi/mL). (3)

CONTRAINDICATIONS

- None (4)

WARNINGS AND PRECAUTIONS

- Risk with exercise or pharmacologic stress:
 - Continuous cardiac monitoring should be performed in studying patients with known or suspected coronary artery disease (5.1)
 - When pharmacologic stress is selected as an alternative to exercise, perform the procedure in accordance with the pharmacologic stress agent's prescribing information (5.1)
- Appropriate safety measures should be used to minimize radiation exposure to clinical personnel and to the patient consistent with proper patient management (2.1, 5.2)

ADVERSE REACTIONS

Most common adverse reactions (incidence < 1%) after MYOVIEW injection: Cardiovascular: angina, hypertension, torsades de pointes. Gastrointestinal: vomiting, abdominal discomfort. Hypersensitivity: cutaneous allergy, hypotension, dyspnea. Special Senses: metallic taste, burning of the mouth, smell alteration. (6.1)

To report SUSPECTED ADVERSE REACTIONS, contact GE Healthcare at 1-800-654-0118 or FDA at 1-800-FDA-1088 or www.fda.gov/medwatch.

USE IN SPECIFIC POPULATIONS

- Advise the pregnant woman of the potential risk to the fetus based on the radiation dose from technetium Tc99m and the gestational timing of exposure (8.1)
- Lactation - A lactating woman should pump and discard breast milk for 60 hours after technetium Tc99m tetrofosmin administration (8.2)

See 17 for PATIENT COUNSELING INFORMATION

Revised: 12/2022

FULL PRESCRIBING INFORMATION: CONTENTS*

1 INDICATIONS AND USAGE

- 1.1 Myocardial Perfusion Imaging
- 1.2 Ventricular Function Imaging

2 DOSAGE AND ADMINISTRATION

- 2.1 Radiation Safety— Drug Handling
- 2.2 Recommended Dosage
- 2.3 Administration Instructions
- 2.4 Instructions for Preparation
- 2.5 Determination of Radiochemical Purity
- 2.6 Imaging Instructions
- 2.7 Radiation Dosimetry

3 DOSAGE FORMS AND STRENGTHS

4 CONTRAINDICATIONS

5 WARNINGS AND PRECAUTIONS

- 5.1 Risks Associated with Exercise and Pharmacologic Stress
- 5.2 Radiation Risks
- 5.3 Hypersensitivity Reactions

6 ADVERSE REACTIONS

- 6.1 Clinical Trials Experience
- 6.2 Postmarketing Experience

8 USE IN SPECIFIC POPULATIONS

- 8.1 Pregnancy
- 8.2 Lactation
- 8.4 Pediatric Use
- 8.5 Geriatric Use

11 DESCRIPTION

- 11.1 Chemical Characteristics
- 11.2 Physical Characteristics
- 11.3 External Radiation

12 CLINICAL PHARMACOLOGY

- 12.1 Mechanism of Action
- 12.2 Pharmacodynamics
- 12.3 Pharmacokinetics

13 NONCLINICAL TOXICOLOGY

- 13.1 Carcinogenesis, Mutagenesis, Impairment of Fertility

14 CLINICAL STUDIES

- 14.1 Exercise/Resting Myocardial Perfusion Imaging Studies
- 14.2 Pharmacological Stress Myocardial Perfusion Imaging Studies
- 14.3 Ventricular Function Stress Myocardial Perfusion Imaging Studies

16 HOW SUPPLIED/STORAGE AND HANDLING

- 16.1 How Supplied
- 16.2 Storage and Handling

17 PATIENT COUNSELING INFORMATION

* Sections or subsections omitted from the full prescribing information are not listed

FULL PRESCRIBING INFORMATION

1 INDICATIONS AND USAGE

1.1 Myocardial Perfusion Imaging

Myocardial perfusion imaging under rest and/or exercise or pharmacologic stress conditions to delineate regions of reversible myocardial ischemia or infarcted myocardium in patients with known or suspected coronary artery disease.

1.2 Ventricular Function Imaging

MYOVIEW is indicated for assessment of left ventricular function (left ventricular ejection fraction and wall motion) in patients with known or suspected heart disease.

2 DOSAGE AND ADMINISTRATION

2.1 Radiation Safety – Drug Handling

Technetium Tc99m tetrofosmin is a radioactive drug and should be handled with appropriate safety measures to minimize radiation exposure during administration [*see Warnings and Precautions (5.2)*]. Use waterproof gloves and effective shielding, including syringe shields, when preparing and administering technetium Tc99m tetrofosmin injection.

2.2 Recommended Dosage

- The recommended dose range for MYOVIEW is 185 to 1,221 MBq (5 to 33 mCi) by intravenous administration for rest and stress imaging.
- When rest and stress intravenous injections are administered on the same day, the first dose should be 185 to 444 MBq (5 to 12 mCi) and followed by the second dose of 555 to 1,221 MBq (15 to 33 mCi) given approximately 1 to 4 hours later.
- The recommended dose range for MYOVIEW is 185 to 1,221 MBq (5 to 33 mCi) by intravenous administration as an intravenous injection for ventricular function assessment.

2.3 Administration Instructions

- Use aseptic technique for all drug preparation and handling.
- Measure the dose in a suitable radioactivity calibration system immediately prior to intravenous administration.
- Visually inspect the drug for particulate matter and discoloration prior to administration. Do not use or administer the drug if there is evidence of particulate matter or discoloration.
- Instruct patients to remain hydrated and void frequently following administration to decrease radiation exposure [*see Warnings and Precautions (5.2)*].

2.4 Instructions for Preparation

1. The technetium Tc99m labeling reaction involved in the preparation of MYOVIEW Injection depends on maintaining tin in the divalent (reduced) state. Any oxidant present in the sodium pertechnetate Tc99m used may adversely affect the quality of the preparation. Sodium pertechnetate Tc99m containing oxidants should not be used for the preparation of the labeled product.
2. Elute the technetium generator with sodium chloride injection, USP.

3. Insert a venting needle (standard 18 to 26 gauge needle, not provided) through the rubber septum of the shielded vial containing the lyophilized powder.
4. Inject no more than 89 GBq (2.4 Ci) of technetium Tc99m generator eluate into the shielded vial.
5. Use sodium chloride injection, USP as a diluent. Inject 10 to 30 mL to achieve a radioactive concentration no greater than 2.96 GBq/mL (80 mCi/mL) in the vial.
6. If a venting needle is not used, before removing the syringe from the vial, withdraw an adequate volume of gas from above the solution to avoid over-pressurizing the vial.
7. Remove the venting needle.
8. Mix gently for 10 seconds to ensure complete dissolution of the powder.
9. Incubate at room temperature for 15 minutes.
10. Assay the total activity using a suitably calibrated instrument; complete the user radiation label and attach it to the vial.
11. Measure the pH of the prepared injection and verify it is between 7.5 to 9.0.
12. Store the radiolabeled MYOVIEW 30 mL vial and withdrawals for injection at 2° to 25°C (36° to 77°F) and use within 12 hours of preparation.

2.5 Determination of Radiochemical Purity

Obtain the following materials:

1. SA TLC strip (2 cm × 20 cm), do not heat activate
2. Ascending chromatography tank and cover
3. Mixture of acetone and dichloromethane (65:35% v/v), prepare freshly
4. Syringe (1 mL) with needle (22 to 25 gauge)
5. Suitable counting equipment

Perform the following:

1. Pour the 65:35% v/v acetone:dichloromethane mixture into the chromatography tank to a depth of 1 cm and cover the tank to allow the solvent vapor to equilibrate.
2. Mark SA TLC strip with a pencil line at 3 cm from the bottom and, using an ink marker pen, at 15 cm from the pencil line. The pencil line indicates the origin where the sample is to be applied and movement of color from the ink line will indicate the position of the solvent front when upward elution should be stopped.
3. Mark cutting positions at 3.75 cm and 12 cm above the origin [retention value (R_f) 0.25 and 0.8 respectively] in pencil.
4. Using a 1 mL syringe and needle, apply a 10 microliter sample of the prepared injection at the origin of the strip. Do not allow the spot to dry. Place the strip in the chromatography tank immediately and replace the cover. Ensure that the strip is not adhering to the walls of the tank. Note: A 10 microliter sample will produce a spot with a diameter of approximately 10 mm. Different sample volumes have been shown to give unreliable radiochemical purity values.
5. When the solvent reaches the ink line, remove the strip from the tank and allow it to dry.
6. Cut the strip into 3 pieces at the marked cutting positions and measure the activity on each using suitable counting equipment. Ensure similar counting geometry for each piece and minimize equipment dead time losses. Note: Free Tc99m pertechnetate runs to the top piece of the strip. MYOVIEW runs to the center piece of the strip. Reduced hydrolyzed Tc99m and any hydrophilic complex impurities remain at the origin in the bottom piece of the strip.

TLC strip diagram

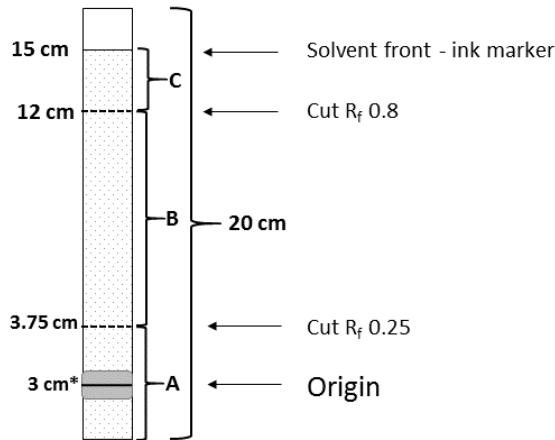

*Measured from plate edge; all other measurements are from origin.
 Count radioactivity in sections A, B, and C separately.
 Percent radiochemical purity = $100\% \times B / (A + B + C)$.

7. Calculate the radiochemical purity from:

$$\% \text{ Tc99m tetrofosmin} = \frac{\text{Activity of center piece}}{\text{Total activity of all 3 pieces}} \times 100$$

8. Do not use material if the radiochemical purity is less than 90%.

2.6 Imaging Instructions

- Imaging may begin 15 minutes after injection.
- The recommended imaging duration of the scan may vary depending on dose, imaging acquisition, and reconstruction parameters.

2.7 Radiation Dosimetry

Radiation absorbed dose per unit activity of the agent injected intravenously in an adult of average weight (74 kg) is estimated in Table 1 for exercise and resting conditions. The values listed correspond to a 3.5-hour voiding period for excretion from the urinary bladder.

Table 1 Estimated Radiation Absorbed Dose (Technetium Tc99m Tetrofosmin Injection)

Target organ	Radiation absorbed dose per unit activity injected intravenously			
	Exercise		Rest	
	rad/mCi	microGy/MBq	rad/mCi	microGy/MBq
Gall bladder wall	0.10	27	0.13	36
Upper large intestine	0.074	20	0.10	27

Lower large intestine	0.055	15	0.074	20
Bladder wall	0.052	14	0.063	17
Small intestine	0.041	11	0.056	15
Kidney	0.037	10	0.048	13
Salivary glands	0.030	8.0	0.043	12
Ovaries	0.029	7.7	0.033	8.8
Uterus	0.026	7.0	0.029	7.8
Bone surface	0.023	6.3	0.021	5.8
Thyroid	0.017	4.7	0.020	5.5
Pancreas	0.019	5.0	0.018	4.9
Heart wall	0.019	5.2	0.017	4.7
Stomach	0.017	4.6	0.017	4.5
Adrenals	0.016	4.4	0.016	4.2
Liver	0.012	3.3	0.015	4.0
Spleen	0.015	4.1	0.014	3.9
Red marrow	0.014	3.9	0.014	3.8
Muscle	0.013	3.5	0.012	3.3
Testes	0.013	3.4	0.011	3.1
Thymus	0.012	3.3	0.010	2.8
Esophagus	0.012	3.3	0.010	2.8
Lungs	0.012	3.2	0.010	2.8
Brain	0.010	2.7	0.0085	2.3
Skin	0.0081	2.2	0.0074	2.0
Breasts	0.0085	2.3	0.0074	2.0
Remaining organs	0.014	3.8	0.014	3.8
Effective dose per unit activity	0.026 rem/mCi	6.9 microSv/MBq	0.030 rem/mCi	8.0 microSv/MBq

3 DOSAGE FORMS AND STRENGTHS

Kit for the preparation of technetium Tc99m tetrofosmin injection: 30 mL multiple-dose, clear, glass vial with a white sterile, non-pyrogenic, lyophilized powder of 1.38 mg tetrofosmin, 0.09 mg stannous chloride dihydrate, 1.92 mg disodium sulphosalicylate, 3 mg sodium D-gluconate, 11 mg sodium hydrogen carbonate, and 3 mg ascorbic acid.

Following radiolabeling with the Tc99m eluate, MYOVIEW is a clear solution not exceeding 2,960 MBq/mL (80 mCi/mL) of Tc99m.

4 CONTRAINDICATIONS

None.

5 WARNINGS AND PRECAUTIONS

5.1 Risks Associated with Exercise or Pharmacologic Stress

Patients evaluated with exercise or pharmacologic stress may experience serious adverse reactions such as myocardial infarction, arrhythmia, hypotension, bronchoconstriction, and cerebrovascular reactions such as headache, paraesthesias, convulsions, somnolence and cerebrovascular accident, including hemorrhage. Perform stress testing in the setting where cardiac resuscitation equipment and trained staff are readily available. When pharmacologic stress is selected as an alternative to exercise, perform the procedure in accordance with the pharmacologic stress agent's prescribing information.

5.2 Radiation Risks

Technetium Tc99m contributes to a patient's overall long-term cumulative radiation exposure. Long-term cumulative radiation exposure is associated with an increased risk of cancer. Ensure safe handling and preparation radiolabeling procedures to protect patients and health care workers from unintentional radiation exposure. Encourage adequate hydration; instruct patients to void when the examination is completed and as often thereafter as possible [*see Dosage and Administration (2.1) and (2.3)*].

5.3 Hypersensitivity Reactions

Hypersensitivity reactions including anaphylaxis, dyspnea, bronchospasm, throat tightness, coughing, tachycardia, chest pain, hypotension, abdominal pain, and cutaneous reactions (rash, urticaria, pruritus, erythema, and swelling or angioedema) have been observed after the administration of MYOVIEW. Always have cardiopulmonary resuscitation equipment and personnel available and monitor all patients for hypersensitivity reactions.

6 ADVERSE REACTIONS

The following clinically significant adverse reactions are described elsewhere in the labeling:

- Hypersensitivity Reactions [*see Warnings and Precautions (5.3)*]

6.1 Clinical Trials Experience

Because clinical trials are conducted under widely varying conditions, adverse reaction rates observed in the clinical trials of MYOVIEW cannot be directly compared to rates in the clinical trials of another drug and may not reflect the rates observed in practice.

Adverse reactions were evaluated in clinical studies (using an exercise/rest protocol) of 764 adults (511 men) with a mean age of 58.7 years (range 29 to 94 years). The subjects received a mean dose of 285 MBq (7.7 mCi) on the first injection and 829 MBq (22.4 mCi) on the second injection of MYOVIEW.

After MYOVIEW injection, angina occurred in 4 subjects, ventricular tachycardia in 1 subject, and respiratory arrest in 1 subject.

The following reactions were noted in less than 1% of subjects:

Cardiovascular: angina, hypertension, torsades de pointes.

Gastrointestinal: vomiting, abdominal discomfort.

Hypersensitivity: cutaneous allergy, hypotension, dyspnea.

Special Senses: metallic taste, burning of the mouth, smell alteration.

In four studies, 438 adults (232 men and 205 women; gender was not recorded for one subject) with a mean age of 65 years (range 27 to 97 years) received a single pharmacologic stress agent. The subjects received a mean dose of 7 to 8 mCi on the rest/first injection and 22 to 34 mCi on the stress/second injection. Among the 438 subjects, 319 subjects (73%) experienced an adverse reaction. Reactions occurring in $\geq 1\%$ of the subjects included angina (39%), flushing (36%), dyspnea (28%), headache (14%), abdominal pain (11%), dizziness (7%), palpitations (2%), nausea (2%), hypotension (1%) and pain (1%). Events occurring in $< 1\%$ include cough, arrhythmia, bronchospasm, ECG abnormalities, hypertension, vomiting and asthenia.

6.2 Postmarketing Experience

The following adverse reactions have been identified during post approval use of MYOVIEW. Because these reactions are reported voluntarily from a population of uncertain size, it is not always possible to reliably estimate their frequency or establish a causal relationship to drug exposure.

The most common adverse reactions reported included: rash, urticaria, abnormal vision, hypersensitivity reactions, and fever.

8 USE IN SPECIFIC POPULATIONS

8.1 Pregnancy

Risk Summary

There are no data with technetium Tc99m tetrafosmin use in pregnant women to inform any drug associated risks. Animal reproduction studies with technetium Tc99m tetrafosmin have not been conducted. However, all radiopharmaceuticals have the potential to cause fetal harm depending on the fetal stage of development and the magnitude of the radiation dose. If considering technetium Tc99m tetrafosmin administration to a pregnant woman advise the pregnant woman of risk to the fetus.

The estimated background risk of major birth defects and miscarriage for the indicated population is unknown. All pregnancies have a background risk of birth defect, loss, or other adverse outcomes. In the U.S. general population, the estimated background risk of major birth defects and miscarriage in clinically recognized pregnancies is 2 to 4% and 15 to 20%, respectively.

8.2 Lactation

Risk Summary

Technetium Tc99m tetrafosmin is present in human milk in small amounts ($< 1\%$ of maternal dose). There are no data available regarding the effects of technetium Tc99m tetrafosmin on the breastfed infant or on milk production. The developmental and health benefits of breastfeeding should be considered along with the mother's clinical need for MYOVIEW and any potential adverse effects on the breastfed child from MYOVIEW or from the underlying maternal condition.

Clinical Considerations

To decrease radiation exposure to the breastfed infant, advise a lactating woman to pump and discard breast milk for 60 hours (10 half-lives) after technetium Tc99m tetrafosmin administration.

8.4 Pediatric Use

Safety and effectiveness in pediatric patients have not been established.

8.5 Geriatric Use

Of 2,300 subjects in clinical studies of MYOVIEW, 1,053 (46%) were 65 or older and 270 (12%) were 75 or older. No overall differences in safety were observed between these subjects and younger subjects, and other reported clinical experience has not identified differences in responses between elderly and younger patients, but greater sensitivity of some older individuals cannot be ruled out.

11 DESCRIPTION

11.1 Chemical Characteristics

MYOVIEW 30 mL is a kit for the preparation of technetium Tc99m tetrofosmin injection for intravenous use. Technetium Tc99m tetrofosmin is a radioactive diagnostic agent. Each multiple-dose 30 mL glass vial contains a sterile, non-pyrogenic, lyophilized powder of 1.38 mg tetrofosmin [6,9- bis(2-ethoxyethyl)-3,12-dioxo-6,9-diphosphatetradecane], 0.09 mg stannous chloride dihydrate, (minimum stannous tin 0.015 mg; total stannous and stannic tin 0.0522 mg) 1.92 mg disodium sulphosalicylate, 3 mg sodium D-gluconate, and 11 mg sodium hydrogen carbonate, and 3 mg ascorbic acid. The lyophilized powder is sealed under a nitrogen atmosphere with a rubber closure. The product contains no antimicrobial preservative. The chemical formula of tetrofosmin is $C_{18}H_{40}O_4P_2$ with the following structural formula:

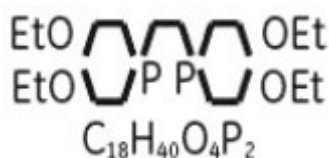

When sterile, pyrogen-free sodium pertechnetate Tc99m in isotonic saline is added to the vial, a Tc99m complex of tetrofosmin is formed. The radiolabeled product is a clear solution and the pH is in the range of 7.5 to 9.0.

11.2 Physical Characteristics

Technetium Tc99m decays by isomeric transition with a physical half-life of 6 hours. Photons that are useful for imaging studies are listed in Table 2.

Table 2 Principal radiation emission data - technetium Tc99m

Radiation	Mean % disintegration	Mean energy (keV)
Gamma 2	88.5	140.5

11.3 External Radiation

The air-kerma-rate (exposure-rate) constant for technetium Tc99m is $5.23 \text{ m}^2 \cdot \text{pGy} \cdot (\text{MBq})^{-1} \cdot \text{s}^{-1}$ [$0.795 \text{ cm}^2 \cdot \text{R} \cdot (\text{mCi})^{-1} \cdot \text{h}^{-1}$].

A range of values for the relative radiation attenuation by various thicknesses of Pb shielding is shown in Table 3. For example, the use of 3 mm thick Pb will decrease the external radiation exposure by a factor of approximately 1,000.

Table 3 Radiation attenuation by lead shielding

Shield thickness (Pb) mm	Factor of attenuation
0.25	0.5
1	10 ⁻¹
2	10 ⁻²
3	10 ⁻³
4	10 ⁻⁴
5	10 ⁻⁵

To correct for physical decay of this radionuclide, the fractions that remain at selected intervals relative to the time of calibration are shown in Table 4.

Table 4 Physical decay chart - Tc99m half-life 6 hours

Hours	Fraction Remaining	Hours	Fraction Remaining
0*	1.000	7	0.446
1	0.891	8	0.397
2	0.794	9	0.354
3	0.707	10	0.315
4	0.630	11	0.281
5	0.562	12	0.250
6	0.500	24	0.063

*Calibration time (time of preparation)

12 CLINICAL PHARMACOLOGY

12.1 Mechanism of Action

Technetium (99mTc) tetrofosmin is a lipophilic, cationic complex which diffuses passively through the cell membrane and is locally retained actively due to the presence of intact mitochondria reflecting the presence of viable cells. After intravenous injection, it is distributed within the myocardium according to myocardial perfusion and viability.

12.2 Pharmacodynamics

The relationship between Tc99m tetrofosmin plasma concentrations and successful imaging has not been explored in clinical trials.

12.3 Pharmacokinetics

Uptake in the myocardium is dependent on coronary flow and reaches a maximum of 1.2% of the injected dose (i.d.) at 5 minutes and 1% of the i.d. at 2 hours, respectively. Background activities in the blood, liver and lung were less than 5% of the administered activity in whole blood at 10 minutes post-injection, less than 4.5% i.d., after 60 minutes, and less than 2% i.d. after 30 minutes.

Elimination

Approximately 66% of the injected activity is excreted within 48 hours post-injection, with approximately 40% excreted in the urine and 26% in the feces.

13 NONCLINICAL TOXICOLOGY

13.1 Carcinogenesis, Mutagenesis, Impairment of Fertility

Studies have not been conducted to evaluate carcinogenic potential or effects on fertility. Tetrofosmin sulphosalicylate was not mutagenic *in vitro* in the Ames test, mouse lymphoma, or human lymphocyte tests, nor was it clastogenic *in vivo* in the mouse micronucleus test.

14 CLINICAL STUDIES

14.1 Exercise/Resting Myocardial Perfusion Imaging Studies

A total of 252 subjects with ischemic heart disease or atypical chest pain were studied in two open-label, multi-center, clinical studies (study a and study b). Of these 252 subjects there were 212 (84%) males and 40 (16%) females with a mean age of 60.5 years (range 33.7 to 82.4 years).

All subjects had exercise and rest planar imaging with MYOVIEW and thallium-201; 191 (76%) subjects also had single photon emission computed tomography (SPECT) imaging. At peak exercise, maximum heart rate achieved and peak systolic blood pressure were comparable after MYOVIEW and thallium-201 exercise studies. The MYOVIEW and thallium-201 images were separated by a mean of 5.1 days (1 to 14 days before or 2 to 14 days after MYOVIEW). For MYOVIEW imaging, each subject received 185 to 296 MBq (5 to 8 mCi) Tc99m tetrofosmin at peak exercise and 555 to 888 MBq (15 to 24 mCi) Tc99m tetrofosmin at rest approximately 4 hours later. For thallium-201 imaging, subjects received thallium-201 55.5 to 74 MBq (1.5 to 2 mCi) at peak exercise.

The images were evaluated for the quality of the image (excellent, good or poor) and the diagnosis (with scores of 0 = normal, 1 = ischemia, 2 = infarct, 3 = mixed infarct and ischemia). The primary outcome variable was the percentage of correct diagnoses in comparison to the final clinical diagnosis. All planar images were blindly read; SPECT images were evaluated by the unblinded investigator. The results for each blinded reader are noted in Table 5.

Table 5 Overall Diagnostic Outcome

Diagnosis	Study	Thallium201		MYOVIEW	
		Reader 1 % (95% CI)	Reader 2 % (95% CI)	Reader 1 % (95% CI)	Reader 2 % (95% CI)
Ischemia	a	77.7 (68.8, 85.0)	75.0 (65.9, 82.7)	66.3 (56.7, 75.1)	63.6 (53.9, 72.6)
	b	75.6 (66.9, 83.0)	68.9 (59.8, 77.1)	66.4 (57.2, 74.8)	66.4 (57.2, 74.8)
Infarct	a	75.9 (66.9, 83.5)	75.0 (65.9, 82.7)	74.5 (65.4, 82.4)	75.5 (66.3, 83.2)
	b	70.6 (61.5, 78.6)	69.7 (60.7, 77.8)	73.1 (64.2, 80.8)	68.1 (58.9, 76.3)

14.2 Pharmacological Stress Myocardial Perfusion Imaging Studies

MYOVIEW imaging after pharmacologic stress was evaluated in two studies in subjects with known or suspected coronary artery disease (CAD). Three blinded reads were obtained for 57 subjects (45 male [79%], 12 female [21%]; mean age 60.1 years) all of whom had angiography. Subject level analyses were based on the finding of SPECT myocardial perfusion abnormalities in patients with

angiographically confirmed disease. Subject level sensitivities for MYOVIEW ranged from 68 to 83% and subject level specificities ranged from 45 to 82% across readers and studies.

14.3 Ventricular Function Stress Myocardial Perfusion Imaging Studies

Two open-label, multicenter, identically designed, blinded image read studies were conducted to assess left ventricular function using MYOVIEW ECG gated SPECT (GSPECT) myocardial perfusion imaging. A total of 329 subjects (216 male [65.7%], 113 female [34.3%]); mean age of 60.4 years) with known or suspected heart disease or requiring ventricular function assessments were dosed with MYOVIEW. Of these, 297 were considered evaluable. MYOVIEW was administered at rest and at peak stress using either a one-day or a 2-day dosing protocol.

For both studies, all subjects' stress GSPECT exams were compared to the reference exam of radionuclide ventriculography with Tc99m labeled RBCs (multiple gated acquisition [MUGA]), performed 1 to 5 days after the second MYOVIEW injection. All subjects' GSPECT exams were assessed by 3 independent blinded readers per study. The MUGA exams were evaluated by an independent consensus panel composed of 3 blinded readers. Subject level assessments were based upon discrimination between normal and abnormal values for LVEF (LVEF \geq 50% was considered normal) and normal and abnormal wall motion as judged visually. Sensitivity and specificity of LVEF determinations ranged from 81% to 88% and 76% to 85% respectively across studies and readers. Sensitivity and specificity of wall motion determinations ranged from 80% to 92% and 68% to 86% respectively across studies and readers.

16 HOW SUPPLIED/STORAGE AND HANDLING

16.1 How supplied

Five (5) multiple-dose kits, each containing a 30 mL glass vial with a sterile, non-pyrogenic, lyophilized powder containing 1.38 mg tetrofosmin, 0.09 stannous chloride dihydrate, 1.92 mg disodium sulphosalicylate, 3 mg sodium D-gluconate, 11 mg sodium hydrogen carbonate and 3 mg ascorbic acid.

NDC 17156-026-30

The radionuclide is not part of the kit. Before radiolabeling with Tc99m, the contents of the kit are not radioactive.

16.2 Storage and Handling

Store the kit at 2° to 8°C (36° to 46°F), protected from light.

Store the radiolabeled vial at 2° to 25°C (36° to 77°F), using appropriate radiation shielding. Use within 12 hours of preparation.

This reagent kit is approved for use by persons under license by the Nuclear Regulatory Commission or the relevant regulatory authority of an Agreement State; store and dispose of technetium Tc99m tetrofosmin in accordance with these regulations.

17 PATIENT COUNSELING INFORMATION

- Instruct patients to remain hydrated and void frequently following administration to decrease radiation exposure.
- Advise a lactating woman to pump and discard breast milk for 60 hours (10 half-lives) after technetium Tc99m tetrofosmin administration to decrease radiation exposure to the breastfed infant.

This label may not be the latest approved by FDA.
For current labeling information, please visit <https://www.fda.gov/drugsatfda>

Manufactured by:
GE Healthcare AS
Oslo, Norway



Distributed by:
GE Healthcare
Medi-Physics, Inc.
Arlington Heights, IL 60004

MYOVIEW is a trademark of GE Healthcare

GE and the GE Monogram are trademarks of General Electric Company.

© 2022 General Electric Company - All rights reserved.

APPEARS THIS WAY ON ORIGINAL

<p>GE Healthcare Rx ONLY Sterile Pyrogen-free Diagnostic For intravenous administration only.</p>	<p>MYOVIEW™ (Kit for the Preparation of Technetium Tc99m Tetrofosmin Injection) 5 x 10 mL 10 mL multiple-dose vials 0.23 mg/vial tetrofosmin</p>	<p>Not for use in humans until Technetium Tc99m is added. Do not use if radiolabeled solution is cloudy. Do not use with sodium pertechnetate Tc99m injection containing oxidizing agent. Contains no antimicrobial preservative. Concentration not exceeding 1,110 MBq/mL (30 mCi/mL) of Tc99m after radiolabeling. Recommended Dosage: See prescribing information. Store the kit in a refrigerator at 2° to 8°C (36° to 46°F), protected from light. Store the radiolabeled injection at 2° to 25°C (36° to 77°F), using appropriate radiation shielding. Use within 12 hours of preparation.</p> <p>1202095 USA</p>	
<p>GE Healthcare Rx ONLY Sterile Pyrogen-free Diagnostic For intravenous administration only.</p>	<p>MYOVIEW™ (Kit for the Preparation of Technetium Tc99m Tetrofosmin Injection) 10 mL 5 x 10 mL multiple-dose vials 0.23 mg/vial tetrofosmin</p>	<p>NDC 17156-024-05 Contents of Kit 5 STERILE REACTION VIALS Each vial contains lyophilized form of: 0.23 mg Tetrofosmin 0.03 mg Stannous chloride dihydrate 0.32 mg Disodium sulphosalicylate 1 mg Sodium D-gluconate 1.8 mg Sodium hydrogen carbonate</p> <p>5 PRESSURE SENSITIVE LABELS 1 PRESCRIBING INFORMATION</p> <p>Myoview is a trademark of GE Healthcare. GE and the GE Monogram are trademarks of General Electric Company. Manufactured for: GE Healthcare Medi-Physics Inc. Arlington Heights, IL 60004 by: GE Healthcare AS, Oslo, Norway</p>	<p>MYOVIEW™ 5 x 10 mL multiple-dose vials</p>  <p>exp: DD MM YYYY LOT: 12345678</p>

12 DZ D98 USA	<p>GE Healthcare R_x ONLY</p> <p>Sterile Pyrogen-free Diagnostic</p> <p>For Intravenous administration only.</p>	<p>MYVIEW™ 30 mL (Kit for the Preparation of Technetium Tc99m Tetrofosmin Injection)</p> <p>5 x 30 mL multiple-dose vials 1.38 mg/vial tetrofosmin</p>	<p>Not for use in humans until Technetium Tc99m is added. Do not use if radiolabeled solution is cloudy. Do not use with sodium pertechnetate Tc99m injection containing oxidizing agent. Contains no antimicrobial preservative.</p> <p>Concentration not exceeding 2,960 MBq/mL (80 mCi/mL) of Tc99m after radiolabeling.</p> <p>Recommended Dosage: See prescribing information.</p> <p>Store the kit in a refrigerator at 2° to 8°C (36° to 46°F), protected from light. Store the radiolabeled injection at 2° to 25°C (36° to 77°F), using appropriate radiation shielding. Use within 12 hours of preparation.</p> 
	<p>GE Healthcare R_x ONLY</p> <p>Sterile Pyrogen-free Diagnostic</p> <p>For Intravenous administration only.</p>	<p>MYVIEW™ 30 mL (Kit for the Preparation of Technetium Tc99m Tetrofosmin Injection)</p> <p>5 x 30 mL multiple-dose vials 1.38 mg/vial tetrofosmin</p>	<p>NDC 17156-026-30</p> <p>Contents of Kit 5 STERILE REACTION VIALS Each vial contains lyophilized form of: 1.38 mg Tetrofosmin 0.09 mg Stannous chloride dihydrate 1.92 mg Disodium sulphosilylate 3 mg Sodium D-gluconate 11 mg Sodium hydrogen carbonate 3 mg Ascorbic acid 5 PRESSURE SENSITIVE LABELS 1 PRESCRIBING INFORMATION</p> <p>Myoview is a trademark of GE Healthcare. GE and the GE Monogram are trademarks of General Electric Company.</p> <p>Manufactured for: GE Healthcare Medi-Physics Inc. Arlington Heights, IL 60004 by: GE Healthcare AS, Oslo, Norway</p> 

GE Healthcare **MYOVIEW™ 30 mL (Kit for the Preparation of Technetium Tc99m Tetrofosmin Injection)**
1202099 USA

Rx ONLY For Intravenous Use

Use within 12 hours of preparation. After radiolabeling with Technetium Tc99m using appropriate radiation shielding, store the radiolabeled vial at 2° to 25°C (36° to 77°F).

Lot No.	Activity	MBq
		mCi
Date	Radiolabeling Time	
Total volume mL	Concentration	MBq/mL
		mCi/mL
Prepared by	Exp. Date & Time	

Mfd for: GE Healthcare,
Medi-Physics Inc., Arlington Hts., IL 60004
by: GE Healthcare AS, Oslo, Norway

**CAUTION
RADIOACTIVE
MATERIAL**



GE Healthcare MYOVIEW™ (Kit for the Preparation of Technetium Tc99m Tetrofosmin Injection)

1202096 USA

R_x ONLY For Intravenous Use

Use within 12 hours of preparation. After radiolabeling with Technetium Tc99m using appropriate radiation shielding, store the radiolabeled vial at 2° to 25°C (36° to 77°F).

Lot No.	Activity	MBq
		mCi
Date	Radiolabeling Time	
Total volume mL	Concentration	MBq/mL
		mCi/mL
Prepared by	Exp. Date & Time	

Mfd for: GE Healthcare,
Medi-Physics Inc., Arlington Hts., IL 60004
by: GE Healthcare AS, Oslo, Norway

**CAUTION
RADIOACTIVE
MATERIAL**



This label may not be the latest approved by FDA.
For current labeling information, please visit <https://www.fda.gov/drugsatfda>



Ramesh
Raghavachari

Digitally signed by Ramesh Raghavachari
Date: 12/06/2022 05:45:14PM
GUID: 502d0913000029f375128b0de8c50020