

PACKAGE INSERT

DESCRIPTION:

VIVITROL™ (naltrexone for extended-release injectable suspension) is supplied as a microsphere formulation of naltrexone for suspension, to be administered by intramuscular injection. Naltrexone is an opioid antagonist with little, if any, opioid agonist activity.

Naltrexone is designated chemically as morphinan-6-one, 17-(cyclopropylmethyl)-4,5-epoxy-3,14-dihydroxy-(5 α) (CAS Registry # 16590-41-3). The molecular formula is C₂₀H₂₃NO₄ and its molecular weight is 341.41 in the anhydrous form (i.e., < 1% maximum water content). The structural formula is:

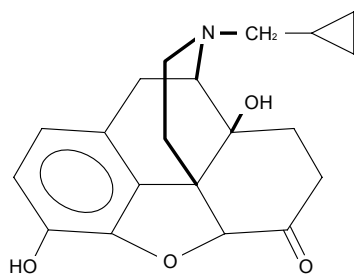

Naltrexone base anhydrous is an off-white to a light tan powder with a melting point of 168-170° C (334-338° F). It is insoluble in water and is soluble in ethanol.

VIVITROL is provided as a kit containing a vial each of VIVITROL microspheres and diluent, one 5-mL syringe, one ½-inch 20-gauge preparation needle, and two 1½-inch 20-gauge administration needles with safety device.

VIVITROL microspheres consist of a sterile, off-white to light-tan powder that is available in a dosage strength of 380-mg naltrexone per vial. Naltrexone is incorporated in 75:25 polylactide-co-glycolide (PLG) at a concentration of 337 mg of naltrexone per gram of microspheres.

The diluent is a clear, colorless solution. The composition of the diluent includes carboxymethylcellulose sodium salt, polysorbate 20, sodium chloride, and water for injection. The microspheres must be suspended in the diluent prior to injection.

CLINICAL PHARMACOLOGY:

Pharmacodynamics

Mechanism of Action

Naltrexone is an opioid antagonist with highest affinity for the μ opioid receptor. Naltrexone has few, if any, intrinsic actions besides its opioid blocking properties. However, it does produce some pupillary constriction, by an unknown mechanism.

The administration of VIVITROL is not associated with the development of tolerance or dependence. In subjects physically dependent on opioids, VIVITROL will precipitate withdrawal symptomatology.

Occupation of opioid receptors by naltrexone may block the effects of endogenous opioid peptides. The neurobiological mechanisms responsible for the reduction in alcohol consumption observed in alcohol-dependent patients treated with naltrexone are not entirely understood. However, involvement of the endogenous opioid system is suggested by preclinical data.

Naltrexone blocks the effects of opioids by competitive binding at opioid receptors. This makes the blockade produced potentially surmountable, but overcoming full naltrexone blockade by administration of opioids may result in non-opioid receptor-mediated symptoms such as histamine release.

VIVITROL is not aversive therapy and does not cause a disulfiram-like reaction either as a result of opiate use or ethanol ingestion.

Pharmacokinetics

Absorption

VIVITROL is an extended-release, microsphere formulation of naltrexone designed to be administered by intramuscular (IM) gluteal injection every 4 weeks or once a month. After IM injection, the naltrexone plasma concentration time profile is characterized by a transient initial peak, which occurs approximately 2 hours after injection, followed by a second peak observed approximately 2 - 3 days later. Beginning approximately 14 days after dosing, concentrations slowly decline, with measurable levels for greater than 1 month.

Maximum plasma concentration (C_{max}) and area under the curve (AUC) for naltrexone and 6 β -naltrexol (the major metabolite) following VIVITROL administration are dose proportional. Compared to daily oral dosing with naltrexone 50 mg over 28 days, total naltrexone exposure is 3 to 4-fold higher following administration of a single dose of VIVITROL 380 mg. Steady state is reached at the end of the dosing interval following the first injection. There is minimal accumulation (<15%) of naltrexone or 6 β -naltrexol upon repeat administration of VIVITROL.

Distribution

In vitro data demonstrate that naltrexone plasma protein binding is low (21%).

Metabolism

Naltrexone is extensively metabolized in humans. Production of the primary metabolite, 6 β -naltrexol, is mediated by dihydrodiol dehydrogenase, a cytosolic family of enzymes. The cytochrome P450 system is not involved in naltrexone metabolism. Two other minor metabolites are 2-hydroxy-3-methoxy-6 β -naltrexol and 2-hydroxy-3-methoxy-naltrexone. Naltrexone and its metabolites are also conjugated to form glucuronide products.

Significantly less 6 β -naltrexol is generated following IM administration of VIVITROL compared to administration of oral naltrexone due to a reduction in first-pass hepatic metabolism.

Elimination

Elimination of naltrexone and its metabolites occurs primarily via urine, with minimal excretion of unchanged naltrexone.

The elimination half life of naltrexone following VIVITROL administration is 5 to 10 days and is dependent on the erosion of the polymer. The elimination half life of 6 β -naltrexol following VIVITROL administration is 5 to 10 days.

Special Populations

Hepatic Impairment: The pharmacokinetics of VIVITROL are not altered in subjects with mild to moderate hepatic impairment (Groups A and B of the Child-Pugh classification). Dose adjustment is not required in subjects with mild or moderate hepatic impairment. VIVITROL pharmacokinetics were not evaluated in subjects with severe hepatic impairment (see PRECAUTIONS).

Renal Impairment: A population pharmacokinetic analysis indicated mild renal insufficiency (creatinine clearance of 50-80 mL/min) had little or no influence on VIVITROL pharmacokinetics and that no dosage adjustment is necessary (see PRECAUTIONS). VIVITROL pharmacokinetics have not been evaluated in subjects with moderate and severe renal insufficiency (see PRECAUTIONS).

Gender: In a study in healthy subjects (n=18 females and 18 males), gender did not influence the pharmacokinetics of VIVITROL.

Age: The pharmacokinetics of VIVITROL have not been evaluated in the geriatric population.

Race: The effect of race on the pharmacokinetics of VIVITROL has not been studied.

Pediatrics: The pharmacokinetics of VIVITROL have not been evaluated in a pediatric population.

Drug-Drug Interactions

Clinical drug interaction studies with VIVITROL have not been performed.

Naltrexone antagonizes the effects of opioid-containing medicines, such as cough and cold remedies, antidiarrheal preparations and opioid analgesics (see PRECAUTIONS).

CLINICAL STUDIES:

The efficacy of VIVITROL in the treatment of alcohol dependence was evaluated in a 24-week, placebo-controlled, multi-center, double-blind, randomized trial of alcohol dependent (DSM-IV criteria) outpatients. Subjects were treated with an injection every 4 weeks of VIVITROL 190 mg, VIVITROL 380 mg or placebo. Oral naltrexone was not administered prior to the initial or subsequent injections of study medication. Psychosocial support was provided to all subjects in addition to medication.

Subjects treated with VIVITROL 380 mg demonstrated a greater reduction in days of heavy drinking than those treated with placebo. Heavy drinking was defined as self-report of 5 or more standard drinks consumed on a given day for male patients and 4 or more drinks for female patients. Among the subset of patients (n=53, 8% of the total study population) who abstained completely from drinking during the week prior to the first dose of medication, compared with placebo-treated patients, those treated with VIVITROL 380 mg had greater reductions in the number of drinking days and the number of heavy drinking days. In this subset, patients treated with VIVITROL were also more likely than placebo-treated patients to maintain complete abstinence throughout treatment. The same treatment effects were not evident among the subset of patients (n=571, 92% of the total study population) who were actively drinking at the time of treatment initiation.

INDICATIONS AND USAGE:

VIVITROL is indicated for the treatment of alcohol dependence in patients who are able to abstain from alcohol in an outpatient setting prior to initiation of treatment with VIVITROL.

Patients should not be actively drinking at the time of initial VIVITROL administration.

Treatment with VIVITROL should be part of a comprehensive management program that includes psychosocial support.

CONTRAINDICATIONS:

VIVITROL is contraindicated in:

- Patients receiving opioid analgesics (see PRECAUTIONS).
- Patients with current physiologic opioid dependence (see WARNINGS).
- Patients in acute opiate withdrawal (see WARNINGS).
- Any individual who has failed the naloxone challenge test or has a positive urine screen for opioids.
- Patients who have previously exhibited hypersensitivity to naltrexone, PLG, carboxymethylcellulose, or any other components of the diluent.

WARNINGS:

Hepatotoxicity

Naltrexone has the capacity to cause hepatocellular injury when given in excessive doses.

Naltrexone is contraindicated in acute hepatitis or liver failure, and its use in patients with active liver disease must be carefully considered in light of its hepatotoxic effects.

The margin of separation between the apparently safe dose of naltrexone and the dose causing hepatic injury appears to be only five-fold or less. VIVITROL does not appear to be a hepatotoxin at the recommended doses.

Patients should be warned of the risk of hepatic injury and advised to seek medical attention if they experience symptoms of acute hepatitis. Use of VIVITROL should be discontinued in the event of symptoms and/or signs of acute hepatitis.

Eosinophilic pneumonia

In clinical trials with VIVITROL, there was one diagnosed case and one suspected case of eosinophilic pneumonia. Both cases required hospitalization, and resolved after treatment with antibiotics and corticosteroids. Should a person receiving VIVITROL develop progressive dyspnea and hypoxemia, the diagnosis of eosinophilic pneumonia should be considered (see ADVERSE REACTIONS). Patients should be warned of the risk of eosinophilic pneumonia, and advised to seek medical attention should they develop symptoms of pneumonia. Clinicians should consider the possibility of eosinophilic pneumonia in patients who do not respond to antibiotics.

Unintended Precipitation of Opioid Withdrawal

To prevent occurrence of an acute abstinence syndrome (withdrawal) in patients dependent on opioids, or exacerbation of a pre-existing subclinical

abstinence syndrome, patients must be opioid-free for a minimum of 7-10 days before starting VIVITROL treatment. Since the absence of an opioid drug in the urine is often not sufficient proof that a patient is opioid-free, a naloxone challenge test should be employed if the prescribing physician feels there is a risk of precipitating a withdrawal reaction following administration of VIVITROL.

Opioid Overdose Following an Attempt to Overcome Opiate Blockade

VIVITROL is not indicated for the purpose of opioid blockade or the treatment of opiate dependence. Although VIVITROL is a potent antagonist with a prolonged pharmacological effect, the blockade produced by VIVITROL is surmountable. This poses a potential risk to individuals who attempt, on their own, to overcome the blockade by administering large amounts of exogenous opioids. Indeed, any attempt by a patient to overcome the antagonism by taking opioids is very dangerous and may lead to fatal overdose. Injury may arise because the plasma concentration of exogenous opioids attained immediately following their acute administration may be sufficient to overcome the competitive receptor blockade. As a consequence, the patient may be in immediate danger of suffering life-endangering opioid intoxication (e.g., respiratory arrest, circulatory collapse). Patients should be told of the serious consequences of trying to overcome the opioid blockade (see INFORMATION FOR PATIENTS).

There is also the possibility that a patient who had been treated with VIVITROL will respond to lower doses of opioids than previously used. This could result in potentially life-threatening opioid intoxication (respiratory compromise or arrest, circulatory collapse, etc.). Patients should be aware that they may be more sensitive to lower doses of opioids after VIVITROL treatment is discontinued (see INFORMATION FOR PATIENTS).

PRECAUTIONS:

General

When Reversal of VIVITROL Blockade Is Required for Pain Management

In an emergency situation in patients receiving VIVITROL, a suggested plan for pain management is regional analgesia, conscious sedation with a benzodiazepine, and use of non-opioid analgesics or general anesthesia.

In a situation requiring opioid analgesia, the amount of opioid required may be greater than usual, and the resulting respiratory depression may be deeper and more prolonged.

A rapidly acting opioid analgesic which minimizes the duration of respiratory depression is preferred. The amount of analgesic administered should be titrated to the needs of the patient. Non-receptor mediated actions may occur and should be expected (e.g., facial swelling, itching, generalized erythema, or bronchoconstriction), presumably due to histamine release.

Irrespective of the drug chosen to reverse VIVITROL blockade, the patient should be monitored closely by appropriately trained personnel in a setting equipped and staffed for cardiopulmonary resuscitation.

Depression and Suicidality

In controlled clinical trials of VIVITROL, adverse events of a suicidal nature (suicidal ideation, suicide attempts, completed suicides) were infrequent overall, but were more common in VIVITROL-treated patients than in patients treated with placebo (1% vs. 0). In some cases, the suicidal thoughts or behavior occurred after study discontinuation, but were in the context of an episode of depression which began while the patient was on study drug. Two completed suicides occurred, both involving patients treated with VIVITROL.

Depression-related events associated with premature discontinuation of study drug were also more common in VIVITROL-treated (~1%) than in placebo-treated patients (0).

In the 24-week, placebo-controlled pivotal trial, adverse events involving depressed mood were reported by 10% of patients treated with VIVITROL 380 mg, as compared to 5% of patients treated with placebo injections.

Alcohol dependent patients, including those taking VIVITROL, should be monitored for the development of depression or suicidal thinking. Families and caregivers of patients being treated with VIVITROL should be alerted to the need to monitor patients for the emergence of symptoms of depression or suicidality, and to report such symptoms to the patient's health care provider.

Injection Site Reactions

VIVITROL injections may be followed by pain, tenderness, induration, or pruritus. In the clinical trials, one patient developed an area of induration that continued to enlarge after 4 weeks, with subsequent development of necrotic tissue that required surgical excision. Patients should be informed that any concerning injection site reactions should be brought to the attention of the physician (see INFORMATION FOR PATIENTS).

Renal Impairment

VIVITROL pharmacokinetics have not been evaluated in subjects with moderate and severe renal insufficiency. Because naltrexone and its primary metabolite are excreted primarily in the urine, caution is recommended in administering VIVITROL to patients with moderate to severe renal impairment.

Alcohol Withdrawal

Use of VIVITROL does not eliminate nor diminish alcohol withdrawal symptoms.

Intramuscular injections

As with any intramuscular injection, VIVITROL should be administered with caution to patients with thrombocytopenia or any coagulation disorder (e.g., hemophilia and severe hepatic failure).

Information for Patients

Physicians should discuss the following issues with patients for whom they prescribe VIVITROL:

- Patients should be advised to carry documentation to alert medical personnel to the fact that they are taking VIVITROL (naltrexone for extended-release injectable suspension). This will help to ensure that the patients obtain adequate medical treatment in an emergency.
- Patients should be advised that administration of large doses of heroin or any other opioid while on VIVITROL may lead to serious injury, coma, or death.
- Patients should be advised that because VIVITROL can block the effects of opiates and opiate-like drugs, patients will not perceive any effect if they attempt to self-administer heroin or any other opioid drug in small doses while on VIVITROL. Also, patients on VIVITROL may not experience the same effects from opioid containing analgesic, antidiarrheal, or antitussive medications.
- Patients should be advised that if they previously used opioids, they may be more sensitive to lower doses of opioids after VIVITROL treatment is discontinued.
- Patients should be advised that VIVITROL may cause liver injury in people who develop liver disease from other causes. Patients should immediately notify their physician if they develop symptoms and/or signs of liver disease.

- Patients should be advised that VIVITROL may cause an allergic pneumonia. Patients should immediately notify their physician if they develop signs and symptoms of pneumonia, including dyspnea, coughing or wheezing.
 - Patients should be advised that a reaction at the site of VIVITROL injection may occur. Reactions include pain, tenderness, induration, and pruritus. Rarely, serious injection site reactions may occur. Patients should be advised to seek medical attention for worsening skin reactions, particularly if the reaction does not improve one month following the injection.
 - Patients should be advised that they may experience nausea following the initial injection of VIVITROL. These episodes of nausea tend to be mild and subside within a few days post-injection. Patients are less likely to experience nausea in subsequent injections.
 - Patients should be advised that because VIVITROL is an intramuscular injection and not an implanted device, once VIVITROL is injected, it is not possible to remove it from the body.
 - Patients should be advised that VIVITROL has been shown to treat alcohol dependence only when used as part of a treatment program that includes counseling and support.
 - Patients should be advised to notify their physician if they:
 - become pregnant or intend to become pregnant during treatment with VIVITROL.
 - are breast-feeding.
 - experience respiratory symptoms such as dyspnea, coughing, or wheezing when taking VIVITROL.
 - experience significant pain or redness at the site of injection, particularly if the reaction does not improve one month following the injection.
 - experience other unusual or significant side effects while on VIVITROL therapy.
-

Drug Interactions

Patients taking VIVITROL may not benefit from opioid-containing medicines (see PRECAUTIONS, Pain Management).

Because naltrexone is not a substrate for CYP drug metabolizing enzymes, inducers or inhibitors of these enzymes are unlikely to change the clearance of VIVITROL. No clinical drug interaction studies have been performed with VIVITROL to evaluate drug interactions, therefore prescribers should weigh the risks and benefits of concomitant drug use.

The safety profile of patients treated with VIVITROL concomitantly with antidepressants was similar to that of patients taking VIVITROL without antidepressants.

Carcinogenesis, mutagenesis, impairment of fertility

Carcinogenicity studies have not been conducted with VIVITROL.

Carcinogenicity studies of oral naltrexone hydrochloride (administered via the diet) have been conducted in rats and mice. In rats, there were small increases in the numbers of testicular mesotheliomas in males and tumors of vascular origin in males and females. The clinical significance of these findings is not known.

Naltrexone was negative in the following in vitro genotoxicity studies: bacterial reverse mutation assay (Ames test), the heritable translocation assay, CHO cell sister chromatid exchange assay, and the mouse lymphoma gene mutation assay.

Naltrexone was also negative in an in vivo mouse micronucleus assay. In contrast, naltrexone tested positive in the following assays: *Drosophila* recessive lethal frequency assay, non-specific DNA damage in repair tests with *E. coli* and WI-38 cells, and urinalysis for methylated histidine residues.

Naltrexone given orally caused a significant increase in pseudopregnancy and a decrease in pregnancy rates in rats at 100 mg/kg/day (600 mg/m²/day). There was no

effect on male fertility at this dose level. The relevance of these observations to human fertility is not known.

Pregnancy Category C

Reproduction and developmental studies have not been conducted for VIVITROL. Studies with naltrexone administered via the oral route have been conducted in pregnant rats and rabbits.

Teratogenic Effects: Oral naltrexone has been shown to increase the incidence of early fetal loss in rats administered ≥ 30 mg/kg/day (180 mg/m²/day) and rabbits administered ≥ 60 mg/kg/day (720 mg/m²/day).

There are no adequate and well-controlled studies of either naltrexone or VIVITROL in pregnant women. VIVITROL should be used during pregnancy only if the potential benefit justifies the potential risk to the fetus.

Labor and Delivery

The potential effect of VIVITROL on duration of labor and delivery in humans is unknown.

Nursing Mothers

Transfer of naltrexone and 6 β -naltrexol into human milk has been reported with oral naltrexone. Because of the potential for tumorigenicity shown for naltrexone in animal studies, and because of the potential for serious adverse reactions in nursing infants from VIVITROL, a decision should be made whether to discontinue nursing or to discontinue the drug, taking into account the importance of the drug to the mother.

Pediatric Use

The safety and efficacy of VIVITROL have not been established in the pediatric population.

Geriatric Use

In trials of alcohol dependent subjects, 2.6% (n=26) of subjects were >65 years of age, and one patient was >75 years of age. Clinical studies of VIVITROL did not include sufficient numbers of subjects age 65 and over to determine whether they respond differently from younger subjects.

ADVERSE REACTIONS

In all controlled and uncontrolled trials during the premarketing development of VIVITROL, more than 900 patients with alcohol and/or opioid dependence have been treated with VIVITROL. Approximately 400 patients have been treated for 6 months or more, and 230 for 1 year or longer.

Adverse Events Leading to Discontinuation of Treatment

In controlled trials of 6 months or less, 9% of VIVITROL-treated patients discontinued treatment due to an adverse event, as compared to 7% of the patients treated with placebo. Adverse events in the VIVITROL 380-mg group that led to more dropouts were injection site reactions (3%), nausea (2%), pregnancy (1%), headache (1%), and suicide-related events (0.3%). In the placebo group, 1% of patients withdrew due to injection site reactions, and 0% of patients withdrew due to the other adverse events.

Common Adverse Events

The table lists all adverse events, regardless of causality, occurring in $\geq 5\%$ of patients with alcohol dependence, for which the incidence was greater in the combined VIVITROL group than in the placebo group. A majority of VIVITROL-treated patients in clinical studies had adverse events with a maximum intensity of “mild” or “moderate.”

Common Adverse Events (by body system and preferred term/high level group term) in $\geq 5\%$ of patients treated with VIVITROL

Body system	Adverse Event/Preferred Term	Placebo		Naltrexone for extended-release injectable suspension							
		N = 214		400 mg N = 25		380 mg N = 205		190 mg N = 210		All N = 440	
		N	%	N	%	N	%	N	%	N	%
Gastrointestinal disorders	Nausea	24	11	8	32	68	33	53	25	129	29
	Vomiting NOS	12	6	3	12	28	14	22	10	53	12
	Diarrhea ¹	21	10	3	12	27	13	27	13	57	13
	Abdominal pain ²	17	8	4	16	23	11	23	11	50	11
	Dry mouth	9	4	6	24	10	5	8	4	24	5
Infections and infestations	Upper respiratory tract infection–Other ³	28	13	0	0	27	13	25	12	52	12
	Pharyngitis ⁴	23	11	0	0	22	11	35	17	57	13
Psychiatric disorders	Insomnia, sleep disorder	25	12	2	8	29	14	27	13	58	13
	Anxiety ⁵	17	8	2	8	24	12	16	8	42	10
	Depression	9	4	0	0	17	8	7	3	24	5
General disorders and administration site conditions	Any ISR	106	50	22	88	142	69	121	58	285	65
	Injection site tenderness	83	39	18	72	92	45	89	42	199	45
	Injection site induration	18	8	7	28	71	35	52	25	130	30
	Injection site pain	16	7	0	0	34	17	22	10	56	13
	Other ISR (primarily nodules, swelling)	8	4	8	32	30	15	16	8	54	12
	Injection site pruritus	0	0	0	0	21	10	13	6	34	8
	Injection site ecchymosis	11	5	0	0	14	7	9	4	23	5
	Asthenic conditions ⁶	26	12	3	12	47	23	40	19	90	20
Musculoskeletal and connective tissue disorders	Arthralgia, arthritis, joint stiffness	11	5	1	4	24	12	12	6	37	9
	Back pain, back stiffness	10	5	1	4	12	6	14	7	27	6

	Muscle cramps ⁷	3	1	0	0	16	8	5	2	21	5
Skin and subcutaneous tissue disorders	Rash ⁸	8	4	3	12	12	6	10	5	25	6
Nervous system disorders	Headache ⁹	39	18	9	36	51	25	34	16	94	21
	Dizziness, syncope	9	4	4	16	27	13	27	13	58	13
	Somnolence, sedation	2	1	3	12	8	4	9	4	20	5
Metabolism and nutrition disorders	Anorexia, appetite, decreased NOS, appetite disorder NOS	6	3	5	20	30	14	13	6	48	11

1 Includes the preferred terms: diarrhea NOS; frequent bowel movements; gastrointestinal upset; loose stools

2 Includes the preferred terms: abdominal pain NOS; abdominal pain upper; stomach discomfort; abdominal pain lower

3 Includes the preferred terms: upper respiratory tract infection NOS; laryngitis NOS; sinusitis NOS

4 Includes the preferred terms: nasopharyngitis; pharyngitis streptococcal; pharyngitis NOS

5 Includes the preferred terms: anxiety NEC; anxiety aggravated; agitation; obsessive compulsive disorder; panic attack; nervousness; post-traumatic stress

6 Includes the preferred terms: malaise; fatigue (these two comprise the majority of cases); lethargy; sluggishness

7 Includes the preferred terms: muscle cramps; spasms; tightness; twitching; stiffness; rigidity

8 Includes the preferred terms: rash NOS; rash papular; heat rash

9 Includes the preferred terms: headache NOS; sinus headache; migraine; frequent headaches

Laboratory Tests

In clinical trials, subjects on VIVITROL had increases in eosinophil counts relative to subjects on placebo. With continued use of VIVITROL, eosinophil counts returned to normal over a period of several months.

VIVITROL 380-mg was associated with a decrease in platelet count. Patients treated with high dose VIVITROL experienced a mean maximal decrease in platelet count of $17.8 \times 10^3/\mu\text{L}$, compared to $2.6 \times 10^3/\mu\text{L}$ in placebo patients. In randomized controlled trials, VIVITROL was not associated with an increase in bleeding related adverse events.

In short-term, controlled trials, the incidence of AST elevations associated with VIVITROL treatment was similar to that observed with oral naltrexone treatment (1.5% each) and slightly higher than observed with placebo treatment (0.9%).

In short-term controlled trials, more patients treated with Vivitrol 380 mg (11%) and oral naltrexone (17%) shifted from normal creatinine phosphokinase (CPK) levels before treatment to abnormal CPK levels at the end of the trials, compared to placebo patients (8%). In open-label trials, 16% of patients dosed for more than 6 months had increases in CPK. For both the oral naltrexone and Vivitrol 380-mg groups, CPK abnormalities were most frequently in the range of 1-2 x ULN. However, there were reports of CPK abnormalities as high as 4x ULN for the oral naltrexone group, and 35 x ULN for the Vivitrol 380-mg group. Overall, there were no differences between the placebo and naltrexone (oral or injectable) groups with respect to the proportions of patients with a CPK value at least three times the upper limit of normal. No factors other than naltrexone exposure were associated with the CPK elevations.

VIVITROL may be cross-reactive with certain immunoassay methods for the detection of drugs of abuse (specifically opioids) in urine. For further information, reference to the specific immunoassay instructions is recommended.

Other Events Observed During the Premarketing Evaluation of VIVITROL

The following is a list of preferred terms that reflect events reported by alcohol and/or opiate dependent subjects treated with VIVITROL in controlled trials. The listing does not include those events already listed in the previous tables or elsewhere in labeling, those events for which a drug cause was remote, those events which were so general as to be uninformative, and those events reported only once which did not have a substantial probability of being acutely life-threatening.

Gastrointestinal Disorders – constipation, toothache, flatulence, gastroesophageal reflux disease, hemorrhoids, colitis, gastrointestinal hemorrhage, paralytic ileus, perirectal abscess

Infections and Infestations – influenza, bronchitis, urinary tract infection, gastroenteritis, tooth abscess, pneumonia, cellulitis

General Disorders and Administration Site Conditions – pyrexia, lethargy, rigors, chest pain, chest tightness, weight decreased

Psychiatric Disorders – irritability, libido decreased, abnormal dreams, alcohol withdrawal syndrome, agitation, euphoric mood, delirium

Nervous System Disorders – dysgeusia, disturbance in attention, migraine, mental impairment, convulsions, ischemic stroke, cerebral arterial aneurysm

Musculoskeletal and Connective Tissue Disorders – pain in limb, muscle spasms, joint stiffness

Skin and Subcutaneous Tissue Disorders – sweating increased, night sweats, pruritus

Respiratory, Thoracic, and Mediastinal Disorders – pharyngolaryngeal pain, dyspnea, sinus congestion, chronic obstructive airways disease

Metabolism and Nutrition Disorders – appetite increased, heat exhaustion, dehydration, hypercholesterolemia

Vascular Disorders – hypertension, hot flushes, deep venous thrombosis, pulmonary embolism

Eye Disorders – conjunctivitis

Blood and Lymphatic System Disorders – lymphadenopathy (including cervical adenitis), white blood cell count increased

Cardiac Disorders – palpitations, atrial fibrillation, myocardial infarction, angina pectoris, angina unstable, cardiac failure congestive, coronary artery atherosclerosis

Immune System Disorders – seasonal allergy, hypersensitivity reaction (including angioneurotic edema and urticaria)

Pregnancy, Puerperium, and Perinatal Conditions – abortion missed

Hepatobiliary Disorders – cholelithiasis, aspartate aminotransferase increased, alanine aminotransferase increased, cholecystitis acute

DRUG ABUSE AND DEPENDENCE:

Controlled Substance Class

VIVITROL is not a controlled substance.

Physical and Psychological Dependence

Naltrexone, the active ingredient in VIVITROL, is a pure opioid antagonist that does not lead to physical or psychological dependence. Tolerance to the opioid antagonist effect is not known to occur.

OVERDOSAGE:

There is limited experience with overdose of VIVITROL. Single doses up to 784 mg were administered to 5 healthy subjects. There were no serious or severe adverse events. The most common effects were injection site reactions, nausea, abdominal pain, somnolence, and dizziness. There were no significant increases in hepatic enzymes.

In the event of an overdose, appropriate supportive treatment should be initiated.

DOSAGE AND ADMINISTRATION:

VIVITROL must be administered by a health care professional.

The recommended dose of VIVITROL is 380 mg delivered intramuscularly every 4 weeks or once a month. The injection should be administered by a health care professional as an intramuscular (IM) gluteal injection, alternating buttocks, using the

kit components provided (see HOW SUPPLIED). **VIVITROL must not be administered intravenously.**

If a patient misses a dose, he/she should be instructed to receive the next dose as soon as possible.

Pretreatment with oral naltrexone is not required before using VIVITROL.

Reinitiation of Treatment in Patients Previously Discontinued

There are no data to specifically address reinitiation of treatment.

Switching From Oral Naltrexone for Alcohol Dependence

There are no systematically collected data that specifically address the switch from oral naltrexone to VIVITROL.

Preparation of Dose

VIVITROL must be suspended **only** in the diluent supplied in the dose kit and must be administered with the needle supplied in the dose kit. All components (i.e. the microspheres, diluent, preparation needle, and an administration needle with safety device) are required for administration. A spare administration needle is provided in case of clogging. Do not substitute any other components for the components of the dose kit.

HOW SUPPLIED:

VIVITROL (naltrexone for extended-release injectable suspension) is supplied in single use kits. Each kit contains one 380 mg vial of VIVITROL microspheres, one vial containing 4 mL (to deliver 3.4 mL) Diluent for the suspension of VIVITROL, one 5 mL syringe, one ½" 20 gauge needle, and two 1½" 20 gauge needles with safety device: NDC 63459-300-42.

Storage and Handling

The entire dose pack should be stored in the refrigerator (2 - 8°C, 36 - 46°F). Unrefrigerated, VIVITROL can be stored at temperatures not exceeding 25°C (77°F) for no more than 7 days prior to administration. Do not expose the product to temperatures above 25°C (77°F). VIVITROL should not be frozen.

Parenteral products should be visually inspected for particulate matter and discoloration prior to administration whenever solution and container permit. A properly mixed suspension will be milky white, will not contain clumps, and will move freely down the wall of the vial.

Keep out of Reach of Children.

VIVITROL PATIENT PACKAGE INSERT (PPI)

Vivitrol™ [vīv' -ī-trōl]
(naltrexone for extended-release injectable suspension)

Rx ONLY

Manufactured by:
Alkermes, Inc.

88 Sidney St.
Cambridge, MA 02139

What is VIVITROL?

VIVITROL is an injectable medicine for the treatment of alcohol dependence in adults 18 years and older.

To benefit from VIVITROL, you need to stop drinking before starting the medicine.

To be effective, treatment with VIVITROL must be used along with other alcoholism recovery measures such as counseling.

VIVITROL may not work for everyone.

VIVITROL has not been studied in children under the age of 18 years.

What is the most important thing I should know about VIVITROL?

1. VIVITROL may be associated with liver damage or hepatitis.
 - Call your doctor if you develop stomach area pain lasting more than a few days, light-colored bowel movements, dark urine, or yellowing of your eyes.
2. VIVITROL blocks the effects of opioid-containing medicines.
 - You may not feel the same effects of opioid-containing medicines including

medicines for pain, cough and diarrhea.

- You may not feel the same effects if you use or abuse heroin and other illegal (street) opioids.
- Do not take large amounts of opioid medicines to overcome the VIVITROL block. This can lead to serious injury, coma, or death.

3. VIVITROL has been associated with severe allergic pneumonia.

Call your doctor if you develop shortness of breath, coughing or wheezing.

Who should not take VIVITROL?

Do not take VIVITROL if you:

- Are taking or have a physical dependence on opioid-containing medicines. (See “What is the most important information I should know about VIVITROL?”)
- Use or have a physical dependence on opioid street drugs. (See “What is the most important information I should know about VIVITROL?”)
- Are allergic to VIVITROL. The active ingredient is naltrexone. See the end of this leaflet for a complete list of ingredients in VIVITROL.

What should I tell my doctor before starting VIVITROL?

Tell your doctor about all of your medical conditions, including if you:

- Have liver problems
- Use opioid-containing medicines

- Use or abuse street (illegal) drugs
- Have hemophilia or other bleeding problems
- Have kidney problems
- Are pregnant or plan to become pregnant. It is not known if VIVITROL can harm your unborn baby.
- Are breastfeeding. It is not known if VIVITROL passes into your milk, and if it can harm your baby.

Tell your doctor about all the medicines you take, including prescription and non-prescription medicines, vitamins and herbal supplements. Especially tell your doctor if you take any opioid-containing medicines for pain, cough, or diarrhea. (See “What is the most important information I should know about VIVITROL?”)

Carry written information to alert medical personnel that you are taking VIVITROL, so that they can treat you properly in an emergency.

How do I take VIVITROL?

VIVITROL is given as a “shot” (injection) in your buttocks. It is injected by your healthcare provider about once a month. Because VIVITROL is an injection, once it is given you cannot remove it from the body.

If you miss your appointment for VIVITROL injection, schedule another appointment as soon as possible.

Whenever you need medical treatment, be sure to tell the treating doctor or nurse that you are receiving VIVITROL injections.

What should I avoid while taking VIVITROL?

VIVITROL may make you feel dizzy. Do not drive a car, work with machines, or do other dangerous activities until you know how VIVITROL affects you. See “What are the possible side effects of VIVITROL?”

What are the possible side effects of VIVITROL?

VIVITROL may cause side effects including:

- A reaction at the injection site. The reaction could be pain, tenderness, swelling, redness, and/or itching. Tell your doctor if the reaction gets worse over time.
- Nausea.

The other common side effects of VIVITROL are:

- Headache
- Fatigue
- Dizziness
- Vomiting
- Decreased appetite
- Painful joints
- Muscle cramps

Tell your doctor about any side effect that bothers you or that does not go away.

These are not all the side effects of VIVITROL. For more information, ask your doctor or pharmacist.

General information about VIVITROL

Medicines are sometimes prescribed for conditions other than those listed in patient information leaflets. VIVITROL was prescribed for your medical condition.

This leaflet summarizes the most important information about VIVITROL. If you would like more information, talk with your doctor. You can ask your doctor or pharmacist for information about VIVITROL that is written for health professionals. For additional information about VIVITROL and treatment support for alcohol dependence call 1-800-848-4873 or visit www.VIVITROL.com

What are the ingredients in VIVITROL?

Active ingredient: naltrexone

Inactive ingredients: polylactide-co-glycolide (PLG); Diluent: carboxymethylcellulose sodium salt, polysorbate 20, sodium chloride, and water

Directions for Use:
To ensure proper dosing, it is important that you follow the preparation and administration instructions outlined in this document.

Product to be prepared and administered by a healthcare professional.
Do not substitute kit components.
Keep out of reach of children.
Prepare and administer the VIVITROL suspension using aseptic technique.

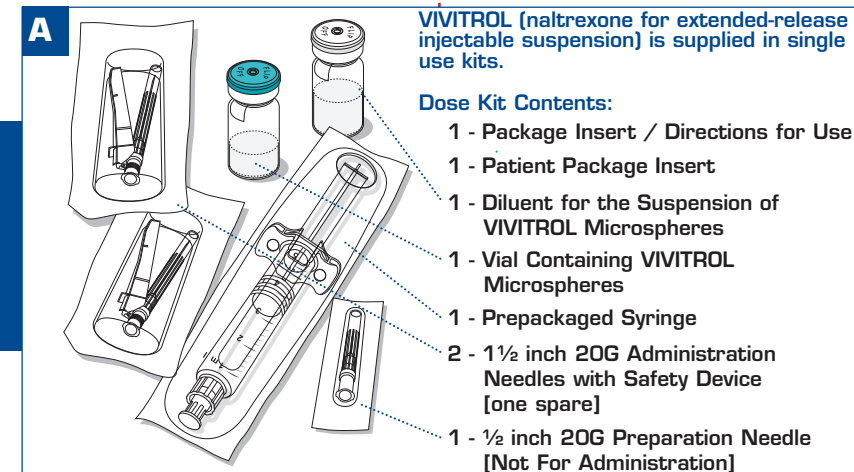

THE KIT SHOULD NOT BE EXPOSED TO TEMPERATURES EXCEEDING 25 °C (77 °F).

VIVITROL must be suspended only in the diluent supplied in the dose kit, and must be administered with the needle supplied in the dose kit. Do not make any substitutions for components of the dose kit.

The entire dose kit should be stored in the refrigerator (2-8 °C, 36-46 °F). Unrefrigerated, VIVITROL Microspheres can be stored at temperatures not exceeding 25 °C (77 °F) for no more than 7 days prior to administration. Do not expose unrefrigerated product to temperatures above 25 °C (77 °F). VIVITROL should not be frozen.

Parenteral products should be visually inspected for particulate matter and discoloration prior to administration whenever solution and container permit.

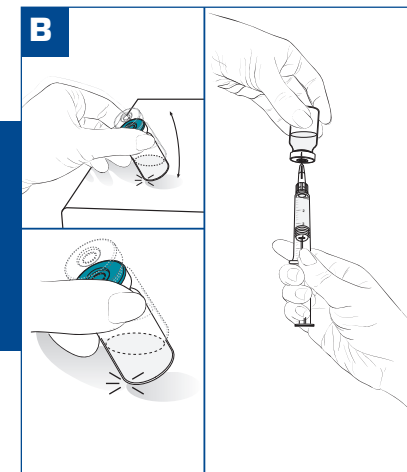

1. Remove the kit from refrigeration. Prior to preparation, allow drug to reach room temperature (approximately 45 minutes).
2. To ease mixing, firmly tap the vial on a hard surface, ensuring the powder moves freely. (see Figure B)
3. Remove flip-off caps from both vials. DO NOT USE IF FLIP-OFF CAPS ARE BROKEN OR MISSING.
4. Wipe the vial tops with an alcohol swab.
5. Place the ½ inch preparation needle on the syringe and withdraw 3.4 mL of the diluent from the diluent vial. Some diluent will remain in the diluent vial. (see Figure B)

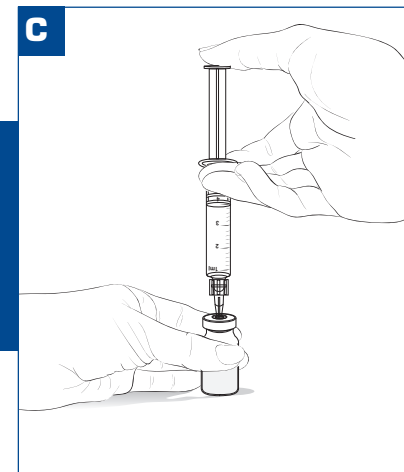

Inject the 3.4 mL of diluent into the VIVITROL Microsphere vial. (see Figure C)

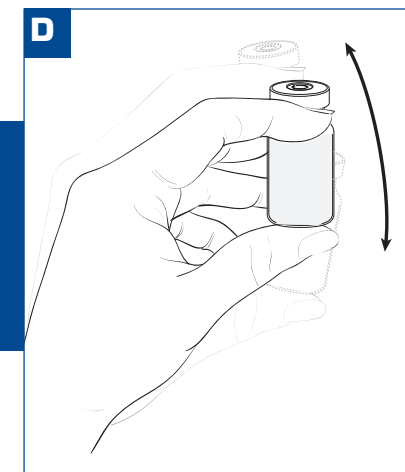

Mix the powder and diluent by vigorously shaking the vial for approximately 1 minute. (see Figure D) Ensure that the dose is thoroughly suspended prior to proceeding to Step E.

A PROPERLY MIXED SUSPENSION WILL BE MILKY WHITE, WILL NOT CONTAIN CLUMPS, AND WILL MOVE FREELY DOWN THE WALLS OF THE VIAL

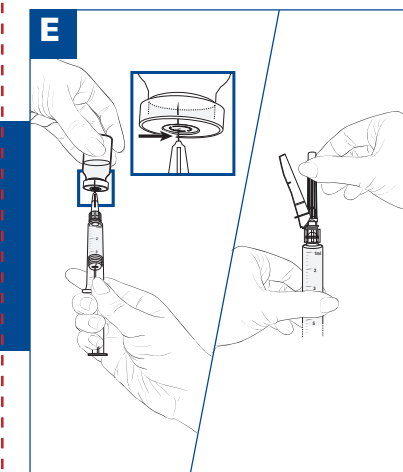

1. Immediately after suspension, withdraw 4.2 mL of the suspension into the syringe using the same preparation needle.
2. Remove the preparation needle and replace with a 1½ inch administration needle for immediate use. (see Figure E)

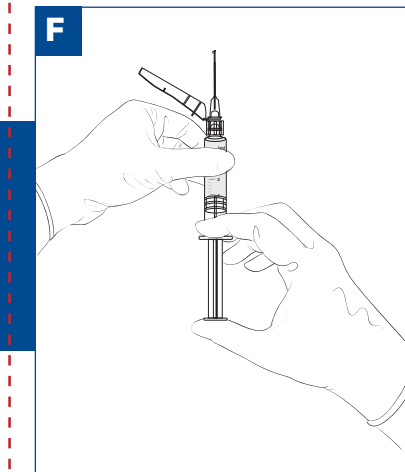

Prior to injecting, tap the syringe to release any air bubbles, then push gently on the plunger until 4 mL of the suspension remains in the syringe. (see Figure F)

THE SUSPENSION IS NOW READY FOR IMMEDIATE ADMINISTRATION.

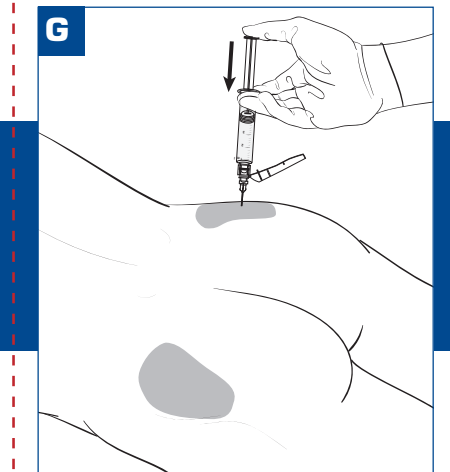

1. Administer the suspension by deep intramuscular (IM) injection into a gluteal muscle, alternating buttocks per injection. Remember to aspirate for blood before injection. (see Figure G)
2. Inject the suspension in a smooth and continuous motion.
3. If blood aspirates or the needle clogs, do not inject. Change to the spare needle provided in the kit and administer into an adjacent site in the same gluteal region, again aspirating for blood before injection.

VIVITROL must NOT be given intravenously.

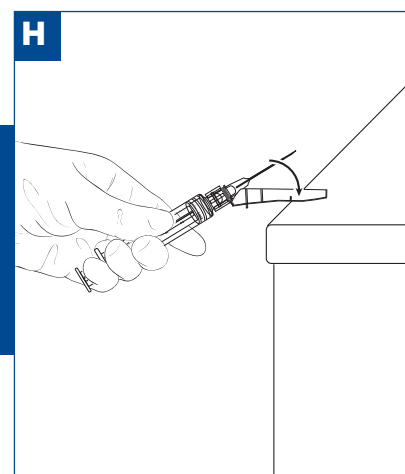

After the injection is administered, cover the needle by pressing the safety sheath against a hard surface using a one-handed motion away from self and others. (see Figure H)

Activation of the safety sheath may cause minimum splatter of fluid that may remain on the needle after injection.

DISPOSE OF USED AND UNUSED ITEMS IN PROPER WASTE CONTAINERS

FREQUENTLY ASKED QUESTIONS:

1. Can I prepare the suspension prior to my patient's arrival?

No. You may remove the kit from the refrigerator prior to the patient's arrival, but once the diluent is added to the VIVITROL Microspheres, the dose should be mixed and the suspension administered immediately. It is very important to use proper aseptic technique when preparing the suspension.

2. How much time do I have between preparing and administering the dose?

It is recommended that the suspension be administered immediately once the product has been suspended and transferred into the syringe. If a few minutes' delay occurs after suspension but before transfer into the syringe (Figure D), the vial can be inverted a few times to resuspend and then transferred into the syringe for immediate use.

3. Can I use needles other than those provided in the kit?

The needles in the kit are specially designed for administration of VIVITROL. Do not make any substitutions for components of the dose kit.

4. The suspension is milky white upon mixing with the diluent. Is this normal?

Yes. VIVITROL Microspheres will form a milky white suspension when mixed with the provided diluent.

5. What if a needle clog occurs during administration of the product?

If a clog occurs during administration, the needle should be withdrawn from the patient, capped with the attached safety device, and replaced with the spare administration needle provided. Gently push on the plunger until a bead of the suspension appears at the tip of the needle. The remainder of the suspension should then be administered into an adjacent site in the same gluteal region.

380 mg/vial Dose Kit
Vivitrol[™]
(naltrexone for extended-release injectable suspension)



1st Check

2nd Check

Final Check

NDC: 63459-300-42

380 mg/vial Dose Kit

Vivitrol[™]
 (Naltrexone for Extended-release Injectable Suspension)

Please see accompanying full prescribing information.

For further information
 call 1-800-XXX-XXXX

Manufactured by: Alkermes, Inc., Cambridge, MA 02139
 Marketed by: Cephalon, Inc., Frazer, PA 19355

NDC: 63459-300-42

380 mg/vial Dose Kit

Vivitrol[™]
 (Naltrexone for Extended-Release Injectable Suspension)

Rx Only

For gluteal intramuscular injection only.
 Single use vial.
 Discard unused portion.
 Must reconstitute **VIVITROL**[™]
 Microspheres with the enclosed diluent
 prior to administration.

See back panel for contents of kit.
 Do not substitute any components of the dose kit.
 Store refrigerated at 2-8°C (36-46°F)

NDC: 63459-300-42

VIVITROL[™] 380 mg/vial
 Dose Kit
 (Naltrexone for Extended-release Injectable Suspension)



NDC: 63459-300-42

380 mg/vial Dose Kit

Vivitrol[™]
 (Naltrexone for Extended-release Injectable Suspension)

LOT XXX-XXXXX EXP MMMYYYY



9001194-01

CH



Storage: Store in outer carton, refrigerated at 2-8°C (36-46°F).
 If refrigeration is unavailable, product can be stored at
 7 days prior to administration. Do not expose unrefrigerated
 product to temperatures above 25°C (77°F).
 Remove the dose kit from the refrigerator and allow it to
 come to room temperature prior to preparation.
 Keep out of reach of children.

*VIVITROL[™] Microspheres: 380 mg of naltrexone per vial, contained in a biodegradable
 matrix of 75:25 polylactide-co-glycolide at a concentration of 337 mg of naltrexone per
 gram of microspheres.
 †Diluent contains (carboxymethylcellulose sodium salt, polysorbate 20,
 sodium chloride, and sterile water for injection).
 Please see accompanying full prescribing information. Reconstitution of the
 microspheres into a suspension is necessary prior to administration. Must
 reconstitute VIVITROL[™] Microspheres with enclosed diluent prior to
 administration. Upon reconstitution with 3.4 mL diluent, each mL will contain
 95 mg of naltrexone.

Each Dose Kit of VIVITROL[™] (Naltrexone for Extended-release
 Injectable Suspension) contains:
 One vial of 380 mg of VIVITROL[™] Microspheres* (Naltrexone Microspheres)
 One vial containing 4 mL of Diluent†
 One 5 mL prepackaged syringe
 One 20-gauge ½ inch needle
 Two 20-gauge 1½ inch safety needles
 Directions for Use, Package Insert and Patient Package Insert

Rx Only



9001194-01



3 63459-300-42 8

PLATE # 13807 DIE # 13807
 PMS 186 RED PMS 116 YELLOW
 PMS 320 GREEN COOL GRAY 10
 BLACK DIE LINE ACRYLIC

Revised 11/10/05 11:54

Peel back to open



9001195-01

LOT XXX-XXXXX EXP MMYYYY

Each Dose Kit of VIVITROL™ (Naltrexone for Extended-release Injectable Suspension) contains:
One vial of 380 mg of VIVITROL™ Microspheres* (Naltrexone Microspheres)
One vial containing 4 mL of Diluent†
One 5 mL prepackaged syringe
One 20-gauge ½ inch needle
Two 20-gauge 1½ inch safety needles

*VIVITROL™ Microspheres: 380 mg of naltrexone per vial, contained in a biodegradable matrix of 75:25 polylactide-co-glycolide at a concentration of 337 mg of naltrexone per gram of microspheres.
†Diluent contains (carboxymethylcellulose sodium salt, polysorbate 20, sodium chloride, and sterile water for injection).

Store refrigerated at 2°-8°C (36°-46°F)
Please see accompanying full prescribing information.

NDC: 63459-300-42 380mg/vial Dose Kit Rx Only

 **Vivitrol**™ Kit
(Naltrexone for Extended-release Injectable Suspension)

Marketed by: Cephalon, Inc., Frazer, PA
Manufactured by: Alkermes, Inc., Cambridge, MA

 **Cephalon**





Pantone 280

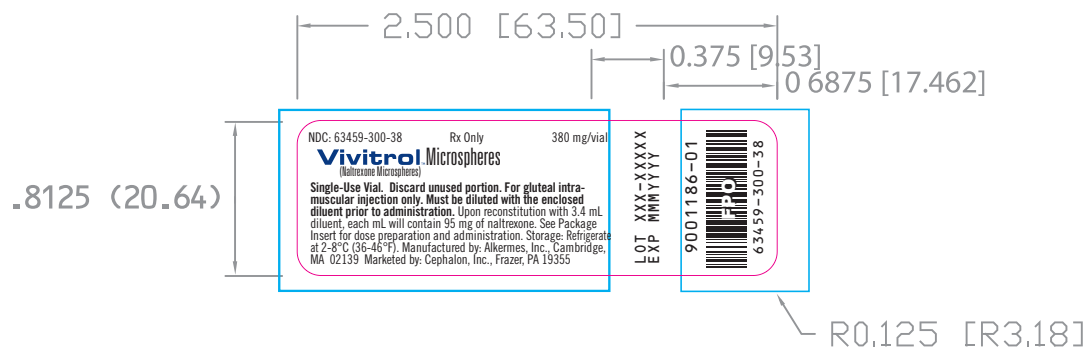

Black



LEGEND	
Dieline	Varnish

Customer/Product:
Date Prepared: 11/ 11/05
Prepared By:
Die#: L122

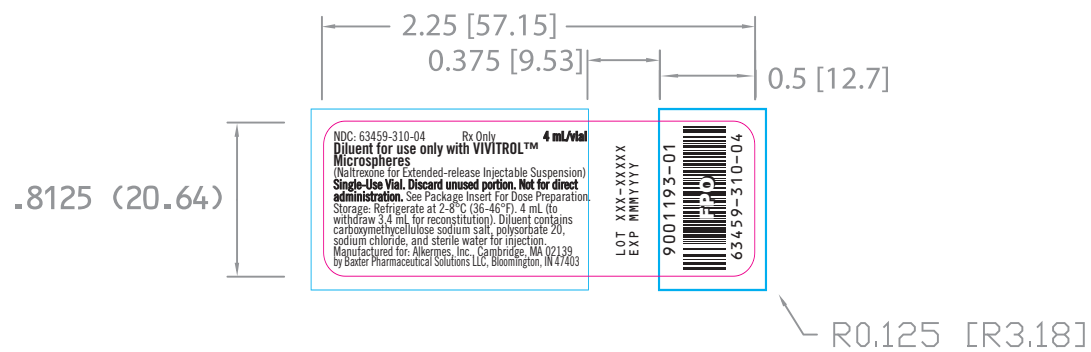
Label Size: 2.5 x .8125
Corner Radius: .125
Comments:



LEGEND	
Dieline	Varnish

Customer/Product:
Date Prepared: 11/11/05
Prepared By:
Die#: L123

Label Size: 2.25 x .8125
Corner Radius: .125
Comments: