

**HIGHLIGHTS OF PRESCRIBING INFORMATION**

These highlights do not include all the information needed to use BETASERON safely and effectively. See full prescribing information for BETASERON.

**BETASERON (interferon beta-1b) for injection, for subcutaneous use**  
Initial U.S. Approval: 1993

----- **RECENT MAJOR CHANGES** -----

Dosage and Administration (2.3) 9/2015

----- **INDICATIONS AND USAGE** -----

BETASERON is an interferon beta indicated for the treatment of relapsing forms of multiple sclerosis to reduce the frequency of clinical exacerbations. Patients with multiple sclerosis in whom efficacy has been demonstrated include patients who have experienced a first clinical episode and have MRI features consistent with multiple sclerosis. (1)

----- **DOSAGE AND ADMINISTRATION** -----

- For subcutaneous use only (2.1)
- The recommended dose is 0.25 mg every other day. Generally, start at 0.0625 mg (0.25 mL) every other day, and increase over a six-week period to 0.25 mg (1 mL) every other day. (2.1)
- Reconstitute lyophilized powder with supplied diluent (2.2)

----- **DOSAGE FORMS AND STRENGTHS** -----

For injection: 0.3 mg of lyophilized powder in a single-use vial for reconstitution (3)

----- **CONTRAINDICATIONS** -----

History of hypersensitivity to natural or recombinant interferon beta, albumin or mannitol (4)

----- **WARNINGS AND PRECAUTIONS** -----

- *Hepatic Injury*: Monitor liver function tests and signs and symptoms of hepatic injury; consider discontinuing BETASERON if serious hepatic injury occurs. (5.1, 5.9)

- *Anaphylaxis and Other Allergic Reactions*: Discontinue if anaphylaxis occurs. (5.2)
- *Depression and Suicide*: Advise patients to immediately report any symptom of depression and/or suicidal ideation; consider discontinuation of BETASERON if depression occurs. (5.3)
- *Congestive Heart Failure (CHF)*: Monitor patients with CHF for worsening of cardiac symptoms; consider discontinuation of BETASERON if worsening of CHF occurs. (5.4)
- *Injection Site Necrosis and Reactions*: Do not administer BETASERON into affected area until fully healed; if multiple lesions occur, discontinue BETASERON until healing of skin lesions. (5.5)
- *Leukopenia*: Monitor complete blood count. (5.6, 5.9)
- *Flu-like Symptom Complex*: Consider analgesics and/or antipyretics on injection days. (5.7)

----- **ADVERSE REACTIONS** -----

In controlled clinical trials, the most common adverse reactions (at least 5% more frequent on BETASERON than on placebo) were: injection site reaction, lymphopenia, flu-like symptoms, myalgia, leukopenia, neutropenia, increased liver enzymes, headache, hypertonia, pain, rash, insomnia, abdominal pain, and asthenia. (6.1)

To report SUSPECTED ADVERSE REACTIONS, contact Bayer HealthCare Pharmaceuticals at 1-888-842-2937 or FDA at 1-800-FDA-1088 or [www.fda.gov/medwatch](http://www.fda.gov/medwatch).

----- **USE IN SPECIFIC POPULATIONS** -----

*Pregnancy*: Based on animal data, may cause fetal harm. (8.1)

See 17 for PATIENT COUNSELING INFORMATION and FDA-Approved Medication Guide

Revised: 9/2015

**FULL PRESCRIBING INFORMATION: CONTENTS\***

**1 INDICATIONS AND USAGE**

**2 DOSAGE AND ADMINISTRATION**

- 2.1 Dosing Information
- 2.2 Reconstitution of the Lyophilized Powder
- 2.3 Important Administration Instructions
- 2.4 Premedication for Flu-like Symptoms

**3 DOSAGE FORMS AND STRENGTHS**

**4 CONTRAINDICATIONS**

**5 WARNINGS AND PRECAUTIONS**

- 5.1 Hepatic Injury
- 5.2 Anaphylaxis and Other Allergic Reactions
- 5.3 Depression and Suicide
- 5.4 Congestive Heart Failure
- 5.5 Injection Site Necrosis and Reactions
- 5.6 Leukopenia
- 5.7 Flu-like Symptom Complex
- 5.8 Seizures
- 5.9 Monitoring for Laboratory Abnormalities

**6 ADVERSE REACTIONS**

- 6.1 Clinical Trials Experience

6.2 Immunogenicity

6.3 Postmarketing Experience

**8 USE IN SPECIFIC POPULATIONS**

- 8.1 Pregnancy
- 8.3 Nursing Mothers
- 8.4 Pediatric Use
- 8.5 Geriatric Use

**11 DESCRIPTION**

**12 CLINICAL PHARMACOLOGY**

- 12.1 Mechanism of Action
- 12.2 Pharmacodynamics
- 12.3 Pharmacokinetics

**13 NONCLINICAL TOXICOLOGY**

- 13.1 Carcinogenesis, Mutagenesis, Impairment of Fertility

**14 CLINICAL STUDIES**

**16 HOW SUPPLIED/STORAGE AND HANDLING**

- 16.1 How Supplied
- 16.2 Stability and Storage

**17 PATIENT COUNSELING INFORMATION**

\*Sections or subsections omitted from the Full Prescribing Information are not listed.

## FULL PRESCRIBING INFORMATION

### 1 INDICATIONS AND USAGE

BETASERON (interferon beta-1b) is indicated for the treatment of relapsing forms of multiple sclerosis to reduce the frequency of clinical exacerbations. Patients with multiple sclerosis in whom efficacy has been demonstrated include patients who have experienced a first clinical episode and have MRI features consistent with multiple sclerosis.

### 2 DOSAGE AND ADMINISTRATION

#### 2.1 Dosing Information

The recommended starting dose is 0.0625 mg (0.25 mL) subcutaneously every other day, with dose increases over a six-week period to the recommended dose of 0.25 mg (1 mL) every other day (see [Table 1](#)).

**Table 1: Schedule for Dose Titration**

	BETASERON Dose <sup>1</sup>	Percentage of recommended dose	Volume
Weeks 1-2	0.0625 mg	25%	0.25 mL
Weeks 3-4	0.125 mg	50%	0.5 mL
Weeks 5-6	0.1875 mg	75%	0.75 mL
Week 7 and thereafter	0.25 mg	100%	1 mL

1. Dosed every other day, subcutaneously

If a dose of BETASERON is missed, then it should be taken as soon as the patient remembers or is able to take it. The patient should not take BETASERON on two consecutive days. The next injection should be taken about 48 hours (two days) after that dose. If the patient accidentally takes more than their prescribed dose, or takes it on two consecutive days, they should be instructed to call their healthcare provider immediately.

#### 2.2 Reconstitution of the Lyophilized Powder

(a) Prior to reconstitution, verify that the vial containing lyophilized BETASERON is not cracked or damaged. Do not use cracked or damaged vials.

(b) To reconstitute lyophilized BETASERON for injection, attach the pre-filled syringe containing the diluent (Sodium Chloride, 0.54% Solution) to the BETASERON vial using the vial adapter.

(c) Slowly inject 1.2 mL of diluent into the BETASERON vial.

(d) Gently swirl the vial to dissolve the lyophilized powder completely; **do not shake**. Foaming may occur during reconstitution or if the vial is swirled or shaken too vigorously. If foaming occurs, allow the vial to sit undisturbed until the foam settles.

(e) 1 mL of reconstituted BETASERON solution contains 0.25 mg of interferon beta-1b.

(f) After reconstitution, if not used immediately, refrigerate the reconstituted BETASERON solution at 35°F to 46°F (2°C to 8°C) and use within three hours. **Do not freeze**.

#### 2.3 Important Administration Instructions

(a) BETASERON is intended for use under the guidance and supervision of a physician. If patients or caregivers are to administer BETASERON, train them in the proper technique for self-administering

subcutaneous injections using the prefilled syringe or the optional injection device. The BETACONNECT autoinjector has three adjustable injection depth settings; the healthcare provider should determine the proper depth setting and injection technique. Use only the syringes in the BETASERON packaging with the BETACONNECT autoinjector.

The initial BETASERON injection should be performed under the supervision of an appropriately qualified healthcare provider. Users should demonstrate competency in all aspects of the BETASERON injection prior to independent use. If a patient is to self-administer BETASERON, the physical and cognitive ability of that patient to self-administer and properly dispose of syringes should be assessed. Patients with severe neurological deficits should not self-administer injections without assistance from a trained caregiver.

Appropriate instruction for self-injection or injection by another person should be provided to the patient or their caregiver, including careful review of the BETASERON Medication Guide, the prefilled syringe Instructions for Use, and the BETACONNECT autoinjector Instructions for Use that accompanies the product.

- (b) Visually inspect the reconstituted BETASERON solution before use; discard if it contains particulate matter or is discolored.
- (c) Keeping the syringe and vial adapter in place, turn the assembly over so that the vial is on top. Withdraw the appropriate dose of BETASERON solution. Remove the vial from the vial adapter before injecting BETASERON.
- (d) Use safe disposal procedures for needles and syringes.
- (e) Do not re-use needles or syringes.
- (f) Advise patients and caregivers to rotate sites for subcutaneous injections to minimize the likelihood of severe injection site reactions, including necrosis or localized infection.

#### **2.4 Premedication for Flu-like Symptoms**

Concurrent use of analgesics and/or antipyretics on treatment days may help ameliorate flu-like symptoms associated with BETASERON use [see *Warnings and Precautions* (5.7)].

### **3 DOSAGE FORMS AND STRENGTHS**

For injection: 0.3 mg lyophilized powder in a single-use vial for reconstitution.

### **4 CONTRAINDICATIONS**

BETASERON is contraindicated in patients with a history of hypersensitivity to natural or recombinant interferon beta, Albumin (Human), or any other component of the formulation.

### **5 WARNINGS AND PRECAUTIONS**

#### **5.1 Hepatic Injury**

Severe hepatic injury including cases of hepatic failure, some of which have been due to autoimmune hepatitis, has been rarely reported in patients taking BETASERON. In some cases, these events have occurred in the presence of other drugs or comorbid medical conditions that have been associated with hepatic injury. Consider the potential risk of BETASERON used in combination with known hepatotoxic drugs or other products (eg, alcohol) prior to BETASERON

administration, or when adding new agents to the regimen of patients already on BETASERON. Monitor patients for signs and symptoms of hepatic injury. Consider discontinuing BETASERON if serum transaminase levels significantly increase, or if they are associated with clinical symptoms such as jaundice.

Asymptomatic elevation of serum transaminases is common in patients treated with BETASERON. In controlled clinical trials, elevations of SGPT to greater than five times baseline value were reported in 12% of patients receiving BETASERON (compared to 4% on placebo), and increases of SGOT to greater than five times baseline value were reported in 4% of patients receiving BETASERON (compared to 1% on placebo), leading to dose-reduction or discontinuation of treatment in some patients [see *Adverse Reactions* (6.1)]. Monitor liver function tests [see *Warnings and Precautions* (5.9)].

## **5.2 Anaphylaxis and Other Allergic Reactions**

Anaphylaxis has been reported as a rare complication of BETASERON use. Other allergic reactions have included dyspnea, bronchospasm, tongue edema, skin rash and urticaria [see *Adverse Reactions* (6.1)]. Discontinue BETASERON if anaphylaxis occurs.

## **5.3 Depression and Suicide**

Depression and suicide have been reported to occur with increased frequency in patients receiving interferon beta products, including BETASERON. Advise patients to report any symptom of depression and/or suicidal ideation to their healthcare provider. If a patient develops depression, discontinuation of BETASERON therapy should be considered.

In randomized controlled clinical trials, there were three suicides and eight suicide attempts among the 1532 patients on BETASERON compared to one suicide and four suicide attempts among 965 patients on placebo.

## **5.4 Congestive Heart Failure**

Monitor patients with pre-existing congestive heart failure (CHF) for worsening of their cardiac condition during initiation of and continued treatment with BETASERON. While beta interferons do not have any known direct-acting cardiac toxicity, cases of CHF, cardiomyopathy, and cardiomyopathy with CHF have been reported in patients without known predisposition to these events, and without other known etiologies being established. In some cases, these events have been temporally related to the administration of BETASERON. Recurrence upon rechallenge was observed in some patients. Consider discontinuation of BETASERON if worsening of CHF occurs with no other etiology.

## **5.5 Injection Site Necrosis and Reactions**

Injection site necrosis (ISN) was reported in 4% of BETASERON-treated patients in controlled clinical trials (compared to 0% on placebo) [see *Adverse Reactions* (6.1)]. Typically, ISN occurs within the first four months of therapy, although postmarketing reports have been received of ISN occurring over one year after initiation of therapy. The necrotic lesions are typically 3 cm or less in diameter, but larger areas have been reported. Generally the necrosis has extended only to subcutaneous fat, but has extended to the fascia overlying muscle. In some lesions where biopsy results are available, vasculitis has been reported. For some lesions, debridement, and/or skin grafting have been required. In most cases healing was associated with scarring.

Whether to discontinue therapy following a single site of necrosis is dependent on the extent of necrosis. For patients who continue therapy with BETASERON after injection site necrosis has occurred, avoid administration of BETASERON into the affected area until it is fully healed. If multiple lesions occur, discontinue therapy until healing occurs.

Periodically evaluate patient understanding and use of aseptic self-injection techniques and procedures, particularly if injection site necrosis has occurred.

In controlled clinical trials, injection site reactions occurred in 78% of patients receiving BETASERON with injection site necrosis in 4%. Injection site inflammation (42%), injection site pain (16%), injection site hypersensitivity (4%), injection site necrosis (4%), injection site mass (2%), injection site edema (2%) and nonspecific reactions were significantly associated with BETASERON treatment. The incidence of injection site reactions tended to decrease over time. Approximately 69% of patients experienced injection site reactions during the first three months of treatment, compared to approximately 40% at the end of the studies.

## 5.6 Leukopenia

In controlled clinical trials, leukopenia was reported in 18% of patients receiving BETASERON (compared to 6% on placebo), leading to a reduction of the dose of BETASERON in some patients [see *Adverse Reactions (6.1)*]. Monitoring of complete blood and differential white blood cell counts is recommended. Patients with myelosuppression may require more intensive monitoring of complete blood cell counts, with differential and platelet counts.

## 5.7 Flu-like Symptom Complex

In controlled clinical trials, the rate of flu-like symptom complex for patients on BETASERON was 57% [see *Adverse Reactions (6.1)*]. The incidence decreased over time, with 10% of patients reporting flu-like symptom complex at the end of the studies. The median duration of flu-like symptom complex in Study 1 was 7.5 days [see *Clinical Studies (14)*]. Analgesics and/or antipyretics on treatment days may help ameliorate flu-like symptoms associated with BETASERON use.

## 5.8 Seizures

Seizures have been temporally associated with the use of beta interferons in clinical trials and postmarketing safety surveillance. It is not known whether these events were related to a primary seizure disorder, the effects of multiple sclerosis alone, the use of beta interferons, other potential precipitants of seizures (eg, fever), or to some combination of these.

## 5.9 Monitoring for Laboratory Abnormalities

In addition to those laboratory tests normally required for monitoring patients with multiple sclerosis, complete blood and differential white blood cell counts, platelet counts and blood chemistries, including liver function tests, are recommended at regular intervals (one, three, and six months) following introduction of BETASERON therapy, and then periodically thereafter in the absence of clinical symptoms.

## 6 ADVERSE REACTIONS

The following serious adverse reactions are discussed in more details in other sections of labeling:

- Hepatic Injury [see *Warnings and Precautions (5.1)*]
- Anaphylaxis and Other Allergic Reactions [see *Warnings and Precautions (5.2)*]
- Depression and Suicide [see *Warnings and Precautions (5.3)*]
- Congestive Heart Failure [see *Warnings and Precautions (5.4)*]
- Injection Site Necrosis and Reactions [see *Warnings and Precautions (5.5)*]
- Leukopenia [see *Warnings and Precautions (5.6)*]
- Flu-like Symptom Complex [see *Warnings and Precautions (5.7)*]
- Seizures [see *Warnings and Precautions (5.8)*]

## 6.1 Clinical Trials Experience

Because clinical trials are conducted under widely varying conditions and over varying lengths of time, adverse reaction rates observed in the clinical trials of BETASERON cannot be directly compared to rates in clinical trials of other drugs, and may not reflect the rates observed in practice.

Among 1407 patients with MS treated with BETASERON 0.25 mg every other day (including 1261 patients treated for greater than one year), the most commonly reported adverse reactions (at least 5% more frequent on BETASERON than on placebo) were injection site reaction, lymphopenia, flu-like symptoms, myalgia leukopenia, neutropenia, increased liver enzymes, headache, hypertonia, pain, rash, insomnia, abdominal pain, and asthenia. The most frequently reported adverse reactions resulting in clinical intervention (for example, discontinuation of BETASERON, adjustment in dosage, or the need for concomitant medication to treat an adverse reaction symptom) were depression, flu-like symptom complex, injection site reactions, leukopenia, increased liver enzymes, asthenia, hypertonia, and myasthenia.

[Table 2](#) enumerates adverse reactions and laboratory abnormalities that occurred among patients treated with 0.25 mg of BETASERON every other day by subcutaneous injection in the pooled placebo-controlled trials (Study 1-4) at an incidence that was at least 2% more than that observed in the placebo-treated patients [see *Clinical Studies* ([14](#))].

**Table 2: Adverse Reactions and Laboratory Abnormalities in Patients with MS in Pooled Studies 1, 2, 3, and 4**

Adverse Reaction	Placebo (N=965)	BETASERON (N=1407)
<b>Blood and lymphatic system disorders</b>		
Lymphocytes count decreased (<1500/mm <sup>3</sup> )	66%	86%
Absolute neutrophil count decreased (< 1500/mm <sup>3</sup> )	5%	13%
White blood cell count decreased (<3000/mm <sup>3</sup> )	4%	13%
Lymphadenopathy	3%	6%
<b>Nervous system disorders</b>		
Headache	43%	50%
Insomnia	16%	21%
Incoordination	15%	17%
<b>Vascular disorders</b>		
Hypertension	4%	6%
<b>Respiratory, thoracic and mediastinal disorders</b>		
Dyspnea	3%	6%
<b>Gastrointestinal disorders</b>		
Abdominal pain	11%	16%
<b>Hepatobiliary disorders</b>		
Alanine aminotransferase increased (SGPT > 5 times baseline)	4%	12%
Aspartate aminotransferase increased (SGOT > 5 times baseline)	1%	4%
<b>Skin and subcutaneous tissue disorders</b>		
Rash	15%	21%
Skin disorder	8%	10%
<b>Musculoskeletal and connective tissue disorders</b>		
Hypertonia	33%	40%
Myalgia	14%	23%
<b>Renal and urinary disorders</b>		

Adverse Reaction	Placebo (N=965)	BETASERON (N=1407)
Urinary urgency	8%	11%
<b>Reproductive system and breast disorders</b>		
Metrorrhagia	7%	9%
Impotence	6%	8%
<b>General disorders and administration site conditions</b>		
Injection site reaction <sup>1</sup>	26%	78%
Asthenia	48%	53%
Flu-like symptoms (complex) <sup>2</sup>	37%	57%
Pain	35%	42%
Fever	19%	31%
Chills	9%	21%
Peripheral edema	10%	12%
Chest pain	6%	9%
Malaise	3%	6%
Injection site necrosis	0%	4%

1. "Injection site reaction" comprises all adverse reactions occurring at the injection site (except injection site necrosis), that is, the following terms: injection site reaction, injection site hemorrhage, injection site hypersensitivity, injection site inflammation, injection site mass, injection site pain, injection site edema and injection site atrophy.
2. "Flu-like symptom (complex)" denotes flu syndrome and/or a combination of at least two adverse reactions from fever, chills, myalgia, malaise, sweating.

In addition to the Adverse Reactions listed in [Table 2](#), the following adverse reactions occurred more frequently on BETASERON than on placebo, but with a difference smaller than 2%: alopecia, anxiety, arthralgia, constipation, diarrhea, dizziness, dyspepsia, dysmenorrhea, leg cramps, menorrhagia, myasthenia, nausea, nervousness, palpitations, peripheral vascular disorder, prostatic disorder, tachycardia, urinary frequency, vasodilatation, and weight increase.

### Laboratory Abnormalities

In the four clinical trials (Studies 1, 2, 3, and 4), leukopenia was reported in 18% and 6% of patients in BETASERON- and placebo-treated groups, respectively. No patients were withdrawn or dose reduced for neutropenia in Study 1. Three percent (3%) of patients in Studies 2 and 3 experienced leukopenia and were dose-reduced. Other abnormalities included increase of SGPT to greater than five times baseline value (12%), and increase of SGOT to greater than five times baseline value (4%). In Study 1, two patients were dose reduced for increased hepatic enzymes; one continued on treatment and one was ultimately withdrawn. In Studies 2 and 3, 1.5% of BETASERON patients were dose-reduced or interrupted treatment for increased hepatic enzymes. In Study 4, 1.7% of patients were withdrawn from treatment due to increased hepatic enzymes, two of them after a dose reduction. In Studies 1-4, nine (0.6%) patients were withdrawn from treatment with BETASERON for any laboratory abnormality, including four (0.3%) patients following dose reduction.

## 6.2 Immunogenicity

As with all therapeutic proteins, there is a potential for immunogenicity. Serum samples were monitored for the development of antibodies to BETASERON during Study 1. In patients receiving 0.25 mg every other day 56/124 (45%) were found to have serum neutralizing activity at one or more of the time points tested. In Study 4, neutralizing activity was measured every 6 months and at end of study. At individual visits after start of therapy, activity was observed in 17% up to 25% of the BETASERON-treated patients. Such neutralizing activity was measured at least once in 75 (30%) out of 251 BETASERON patients who provided samples during treatment phase; of these, 17 (23%) converted to negative status later in the study. Based on all the available evidence, the relationship between antibody formation and clinical safety or efficacy is not known.

These data reflect the percentage of patients whose test results were considered positive for antibodies to BETASERON using a biological neutralization assay that measures the ability of immune sera to inhibit the production of the interferon-inducible protein, MxA. Neutralization assays are highly dependent on the sensitivity and specificity of the assay. Additionally, the observed incidence of neutralizing activity in an assay may be influenced by several factors including sample handling, timing of sample collection, concomitant medications, and underlying disease. For these reasons, comparison of the incidence of antibodies to BETASERON with the incidence of antibodies to other products may be misleading.

Anaphylactic reactions have been reported with the use of BETASERON [see *Warnings and Precautions (5.2)*].

### **6.3 Postmarketing Experience**

The following adverse reactions have been identified during postapproval use of BETASERON. Because these reactions are reported voluntarily from a population of uncertain size, it is not always possible to reliably estimate their frequency or establish a causal relationship to drug exposure.

**Blood and lymphatic system disorders:** Anemia, Thrombocytopenia

**Endocrine disorders:** Hypothyroidism, Hyperthyroidism, Thyroid dysfunction

**Metabolism and nutrition disorders:** Triglyceride increased, Anorexia, Weight decrease, Weight increase

**Psychiatric disorders:** Anxiety, Confusion, Emotional lability

**Nervous system disorders:** Convulsion, Dizziness, Psychotic symptoms

**Cardiac disorders:** Cardiomyopathy, Palpitations, Tachycardia

**Vascular disorders:** Vasodilatation

**Respiratory, thoracic and mediastinal disorders:** Bronchospasm

**Gastrointestinal disorders:** Diarrhea, Nausea, Pancreatitis, Vomiting

**Hepatobiliary disorders:** Hepatitis, Gamma GT increased

**Skin and subcutaneous tissue disorders:** Alopecia, Pruritus, Skin discoloration, Urticaria

**Musculoskeletal and connective tissue disorders:** Arthralgia

**Reproductive system and breast disorder:** Menorrhagia

**General disorders and administration site conditions:** Fatal capillary leak syndrome\*

\*The administration of cytokines to patients with a pre-existing monoclonal gammopathy has been associated with the development of this syndrome.

## **8 USE IN SPECIFIC POPULATIONS**

### **8.1 Pregnancy**

Pregnancy Category C: There are no adequate and well-controlled studies in pregnant women; however, spontaneous abortions while on treatment were reported in four patients participating in the BETASERON RRMS clinical trial. BETASERON should be used during pregnancy only if the potential benefit justifies the potential risk to the fetus.

When BETASERON (doses ranging from 0.028 to 0.42 mg/kg/day) was administered to pregnant rhesus monkeys throughout the period of organogenesis (gestation days 20 to 70), a dose-related abortifacient effect was observed. The low-effect dose is approximately 3 times the recommended human dose of 0.25 mg on a body surface area (mg/m<sup>2</sup>) basis. A no-effect dose for embryo-fetal developmental toxicity in rhesus monkeys was not established.

### **8.3 Nursing Mothers**

It is not known whether BETASERON is excreted in human milk. Because many drugs are excreted in human milk and because of the potential for serious adverse reactions in nursing infants from BETASERON, a decision should be made to either discontinue nursing or discontinue the drug, taking into account the importance of drug to the mother.

### **8.4 Pediatric Use**

Safety and efficacy in pediatric patients have not been established.

### **8.5 Geriatric Use**

Clinical studies of BETASERON did not include sufficient numbers of patients aged 65 and over to determine whether they respond differently than younger patients.

## **11 DESCRIPTION**

BETASERON (interferon beta-1b) is a purified, sterile, lyophilized protein product produced by recombinant DNA techniques. Interferon beta-1b is manufactured by bacterial fermentation of a strain of *Escherichia coli* that bears a genetically engineered plasmid containing the gene for human interferon beta<sub>ser17</sub>. The native gene was obtained from human fibroblasts and altered in a way that substitutes serine for the cysteine residue found at position 17. Interferon beta-1b has 165 amino acids and an approximate molecular weight of 18,500 daltons. It does not include the carbohydrate side chains found in the natural material.

The specific activity of BETASERON is approximately 32 million international units (IU)/mg interferon beta-1b. Each vial contains 0.3 mg of interferon beta-1b. The unit measurement is derived by comparing the antiviral activity of the product to the World Health Organization (WHO) reference standard of recombinant human interferon beta. Mannitol, USP and Albumin (Human), USP (15 mg each/vial) are added as stabilizers.

Lyophilized BETASERON is a sterile, white to off-white powder, for subcutaneous injection after reconstitution with the diluent supplied (Sodium Chloride, 0.54% Solution). Albumin (Human) USP and Mannitol, USP (15 mg each/vial) are added as stabilizers.

## **12 CLINICAL PHARMACOLOGY**

### **12.1 Mechanism of Action**

The mechanism of action of BETASERON (interferon beta-1b) in patients with multiple sclerosis is unknown.

### **12.2 Pharmacodynamics**

Interferons (IFNs) are a family of naturally occurring proteins, produced by eukaryotic cells in response to viral infection and other biologic agents. Three major types of interferons have been defined: type I (IFN-alpha, beta, epsilon, kappa and omega), type II (IFN-gamma) and type III (IFN-lambda). Interferon-beta is a member of the type I subset of interferons. The type I interferons have considerably overlapping but also distinct biologic activities. The bioactivities of all IFNs, including IFN-beta, are induced via their binding to specific receptors on the membranes of human cells. Differences in the bioactivities induced by the three major subtypes of IFNs likely reflect differences in the signal transduction pathways induced by signaling through their cognate receptors.

Interferon beta-1b receptor binding induces the expression of proteins that are responsible for the pleiotropic bioactivities of interferon beta-1b. A number of these proteins (including neopterin,  $\beta_2$ -microglobulin, MxA protein, and IL-10) have been measured in blood fractions from BETASERON-treated patients and BETASERON-treated healthy volunteers. Immunomodulatory effects of interferon beta-1b include the enhancement of suppressor T cell activity, reduction of pro-inflammatory cytokine production, down-regulation of antigen presentation, and inhibition of lymphocyte trafficking into the central nervous system. It is not known if these effects play an important role in the observed clinical activity of BETASERON in multiple sclerosis (MS).

### 12.3 Pharmacokinetics

Because serum concentrations of interferon beta-1b are low or not detectable following subcutaneous administration of 0.25 mg or less of BETASERON, pharmacokinetic information in patients with MS receiving the recommended dose of BETASERON is not available.

Following single and multiple daily subcutaneous administrations of 0.5 mg BETASERON to healthy volunteers (N=12), serum interferon beta-1b concentrations were generally below 100 IU/mL. Peak serum interferon beta-1b concentrations occurred between one to eight hours, with a mean peak serum interferon concentration of 40 IU/mL. Bioavailability, based on a total dose of 0.5 mg BETASERON given as two subcutaneous injections at different sites, was approximately 50%.

After intravenous administration of BETASERON (0.006 mg to 2 mg), similar pharmacokinetic profiles were obtained from healthy volunteers (N=12) and from patients with diseases other than MS (N=142). In patients receiving single intravenous doses up to 2 mg, increases in serum concentrations were dose proportional. Mean serum clearance values ranged from 9.4 mL/min•kg<sup>-1</sup> to 28.9 mL/min•kg<sup>-1</sup> and were independent of dose. Mean terminal elimination half-life values ranged from 8 minutes to 4.3 hours and mean steady-state volume of distribution values ranged from 0.25 L/kg to 2.88 L/kg. Three-times-a-week intravenous dosing for two weeks resulted in no accumulation of interferon beta-1b in sera of patients. Pharmacokinetic parameters after single and multiple intravenous doses of BETASERON were comparable.

Following every other day subcutaneous administration of 0.25 mg BETASERON in healthy volunteers, biologic response marker levels (neopterin,  $\beta_2$ -microglobulin, MxA protein, and the immunosuppressive cytokine, IL-10) increased significantly above baseline six-twelve hours after the first BETASERON dose. Biologic response marker levels peaked between 40 and 124 hours and remained elevated above baseline throughout the seven-day (168-hour) study. The relationship between serum interferon beta-1b levels or induced biologic response marker levels and the clinical effects of interferon beta-1b in multiple sclerosis is unknown.

#### *Drug Interaction Studies*

No formal drug interaction studies have been conducted with BETASERON.

## 13 NONCLINICAL TOXICOLOGY

### 13.1 Carcinogenesis, Mutagenesis, Impairment of Fertility

#### *Carcinogenesis*

BETASERON has not been tested for its carcinogenic potential in animals.

#### *Mutagenesis*

BETASERON was not genotoxic in the in vitro Ames bacterial test or the in vitro chromosomal aberration assay in human peripheral blood lymphocytes. BETASERON treatment of mouse BALBc-3T3 cells did not result in increased transformation frequency in an in vitro model of tumor transformation.

### *Impairment of Fertility*

Administration of BETASERON (doses of up to 0.33 mg/kg/day) to normally cycling female rhesus monkeys had no apparent adverse effects on either menstrual cycle duration or associated hormonal profiles (progesterone and estradiol) when administered over three consecutive menstrual cycles. The highest dose tested is approximately 30 times the recommended human dose of 0.25 mg on a body surface area (mg/m<sup>2</sup>) basis. The potential for other effects on fertility or reproductive performance was not evaluated.

## **14 CLINICAL STUDIES**

The clinical effects of BETASERON were studied in four randomized, multicenter, double-blind, placebo-controlled studies in patients with multiple sclerosis (Studies 1, 2, 3, and 4).

### *Patients with Relapsing-Remitting Multiple Sclerosis*

The effectiveness of BETASERON in relapsing-remitting MS (RRMS) was evaluated in a double blind, multiclinic, randomized, parallel, placebo controlled clinical study of two years duration (Study 1). The study enrolled MS patients, aged 18 to 50, who were ambulatory [Kurtzke Expanded Disability Status Scale (EDSS) of  $\leq 5.5$  – score 5.5 is ambulatory for 100 meters, disability precludes full daily activities], exhibited a relapsing-remitting clinical course, met Poser's criteria for clinically definite and/or laboratory supported definite MS and had experienced at least two exacerbations over two years preceding the trial without exacerbation in the preceding month. The EDSS score is a method of quantifying disability in patients with MS and ranges from 0 (normal neurologic exam) to 10 (death due to MS). Patients who had received prior immunosuppressant therapy were excluded.

An exacerbation was defined as the appearance of a new clinical sign/symptom or the clinical worsening of a previous sign/symptom (one that had been stable for at least 30 days) that persisted for a minimum of 24 hours.

Patients selected for study were randomized to treatment with either placebo (N=123), 0.05 mg of BETASERON (N=125), or 0.25 mg of BETASERON (N=124) self-administered subcutaneously every other day. Outcome based on the 372 randomized patients was evaluated after two years.

Patients who required more than three 28-day courses of corticosteroids were removed from the study. Minor analgesics (acetaminophen, codeine), antidepressants, and oral baclofen were allowed ad libitum, but chronic nonsteroidal anti-inflammatory drug (NSAID) use was not allowed.

The primary protocol-defined outcome measures were 1) frequency of exacerbations per patient and 2) proportion of exacerbation free patients. A number of secondary clinical and magnetic resonance imaging (MRI) measures were also employed. All patients underwent annual T2 MRI imaging and a subset of 52 patients at one site had MRIs performed every six weeks for assessment of new or expanding lesions.

The study results are shown in [Table 3](#).

**Table 3: Two Year RRMS Study Results of Primary and Secondary Clinical Outcomes (Study 1)**

Efficacy Parameters		Treatment Groups			Statistical Comparisons p-value		
		Placebo (N=123)	BETASERON 0.05 mg (N=125)	BETASERON 0.25 mg (N=124)	Placebo vs 0.05 mg	0.05 mg vs 0.25 mg	Placebo vs 0.25 mg
<b>Primary End Points</b>							
Annual exacerbation rate		1.31	1.14	0.9	0.005	0.113	<b>0.0001</b>
Proportion of exacerbation-free patients <sup>1</sup>		16%	18%	25%	0.609	0.288	<b>0.094</b>
Exacerbation frequency per patient	0 <sup>1</sup>	20%	22%	29%	0.151	0.077	<b>0.001</b>
	1	32%	31%	39%			
	2	20%	28%	17%			
	3	15%	15%	14%			
	4	15%	7%	9%			
	> 5	21%	16%	8%			
<b>Secondary Endpoints<sup>2</sup></b>							
Median number of months to first on-study exacerbation		5	6	9	0.299	0.097	<b>0.01</b>
Rate of moderate or severe exacerbations per year		0.47	0.29	0.23	0.02	0.257	<b>0.001</b>
Mean number of moderate or severe exacerbation days per patient		44	33	20	0.229	0.064	<b>0.001</b>
Mean change in EDSS score <sup>3</sup> at endpoint		0.21	0.21	-0.07	0.995	0.108	<b>0.144</b>
Mean change in Scripps score <sup>4</sup> at endpoint		-0.53	-0.5	0.66	0.641	0.051	<b>0.126</b>
Median duration in days per exacerbation		36	33	36	ND <sup>5</sup>	ND <sup>5</sup>	<b>ND<sup>5</sup></b>
% change in mean MRI lesion area at endpoint		21.4%	9.8%	-0.9%	0.015	0.019	<b>0.0001</b>

1. 14 exacerbation free patients (0 from placebo, six from 0.05 mg, and eight from 0.25 mg) dropped out of the study before completing six months of therapy. These patients are excluded from this analysis.
2. Sequelae and Functional Neurologic Status, both required by protocol, were not analyzed individually but are included as a function of the EDSS.
3. EDSS scores range from 1-10, with higher scores reflecting greater disability.
4. Scripps neurologic rating scores range from 0-100, with smaller scores reflecting greater disability.
5. ND = Not done.

Of the 372 RRMS patients randomized, 72 (19%) failed to complete two full years on their assigned treatments.

Over the two-year period in Study 1, there were 25 MS-related hospitalizations in the 0.25 mg BETASERON-treated group compared to 48 hospitalizations in the placebo group. In comparison, non-MS hospitalizations were evenly distributed among the groups, with 16 in the 0.25 mg BETASERON group and 15 in the placebo group. The average number of days of MS-related steroid use was 41 days in the 0.25 mg BETASERON group and 55 days in the placebo group (p=0.004).

MRI data were also analyzed for patients in this study. A frequency distribution of the observed percent changes in MRI area at the end of two years was obtained by grouping the percentages in successive intervals of equal width. [Figure 1](#) displays a histogram of the proportions of patients, which fell into each of these intervals. The median percent change in MRI area for the 0.25 mg group was -1.1%, which was significantly smaller than the 16.5% observed for the placebo group (p=0.0001).

Figure 1: Distribution of Change in MRI Area in Patients with RRMS in Study 1

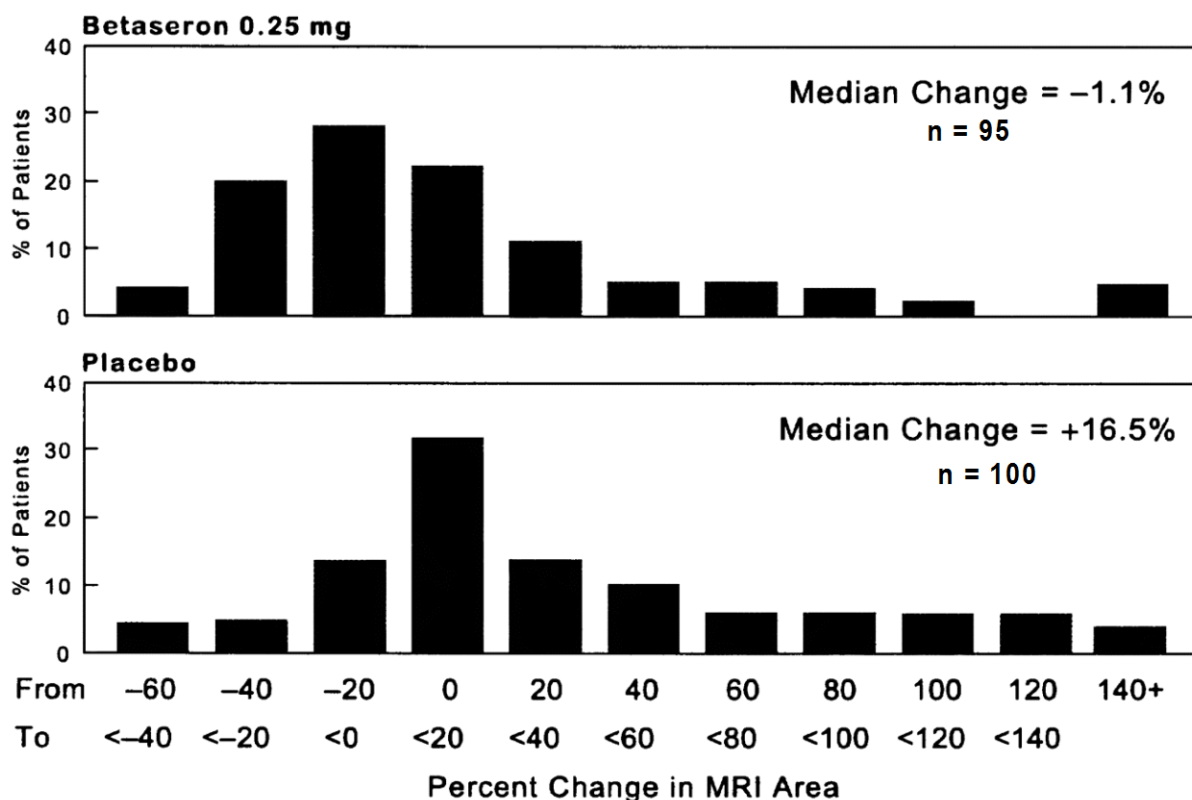

In an evaluation of frequent MRI scans (every six weeks) on 52 patients at one site in Study 1, the percent of scans with new or expanding lesions was 29% in the placebo group and 6% in the 0.25 mg treatment group (p=0.006).

The exact relationship between MRI findings and clinical status of patients is unknown. Changes in lesion area often do not correlate with changes in disability progression. The prognostic significance of the MRI findings in this study has not been evaluated.

#### Patients with Secondary Progressive Multiple Sclerosis

Studies 2 and 3 were multicenter, randomized, double-blind, placebo controlled trials conducted to assess the effect of BETASERON in patients with secondary progressive MS (SPMS). Study 2 was conducted in Europe and Study 3 was conducted in North America. Both studies enrolled patients with clinically definite or laboratory-supported MS in the secondary progressive phase, and who had evidence of disability progression (both Study 2 and 3) or two relapses (Study 2 only) within the previous two years. Baseline Kurtzke expanded disability status scale (EDSS) scores ranged from 3.0 to 6.5. Patients in Study 2 were randomized to receive BETASERON 0.25 mg (N=360) or placebo (N=358). Patients in Study 3 were randomized to receive BETASERON 0.25 mg (N=317), BETASERON 0.16 mg/m<sup>2</sup> of body surface area (N=314, mean assigned dose 0.3 mg), or placebo (N=308). Test agents were administered subcutaneously, every other day for three years.

The primary outcome measure was progression of disability, defined as a 1.0 point increase in the EDSS score, or a 0.5 point increase for patients with baseline EDSS  $\geq$  6.0. In Study 2, time to progression in EDSS was longer in the BETASERON treatment group (p=0.005), with estimated annualized rates of progression of 16% and 19% in the BETASERON and placebo groups, respectively. In Study 3, the rates of progression did not differ significantly between treatment groups, with estimated annualized rates of progression of 12%, 14%, and 12% in the BETASERON fixed dose, surface area-adjusted dose, and placebo groups, respectively.

Multiple analyses, including covariate and subset analyses based on sex, age, disease duration, clinical disease activity prior to study enrollment, MRI measures at baseline and early changes in MRI following treatment were evaluated in order to interpret the discordant study results. No demographic or disease-related factors enabled identification of a patient subset where BETASERON treatment was predictably associated with delayed progression of disability.

In Studies 2 and 3, like Study 1, a statistically significant decrease in the incidence of relapses associated with BETASERON treatment was demonstrated. In Study 2, the mean annual relapse rates were 0.42 and 0.63 in the BETASERON and placebo groups, respectively ( $p < 0.001$ ). In Study 3, the mean annual relapse rates were 0.16, 0.20, and 0.28, for the fixed dose, surface area-adjusted dose, and placebo groups, respectively ( $p < 0.02$ ).

MRI endpoints in both Study 2 and Study 3 showed smaller increases in T2 MRI lesion area and decreased number of active MRI lesions in patients in the BETASERON groups compared to the placebo group. The exact relationship between MRI findings and the clinical status of patients is unknown. Changes in MRI findings often do not correlate with changes in disability progression. The prognostic significance of the MRI findings in these studies is not known.

#### *Patients with an Isolated Demyelinating Event and Typical MS Lesions on Brain MRI*

In Study 4, 468 patients who had recently (within 60 days) experienced an isolated demyelinating event, and who had lesions typical of multiple sclerosis on brain MRI were randomized to receive either 0.25 mg BETASERON (N=292) or placebo (N=176) subcutaneously every other day (ratio 5:3). The primary outcome measure was time to development of a second exacerbation with involvement of at least two distinct anatomical regions. Secondary outcomes were brain MRI measures, including the cumulative number of newly active lesions, and the absolute change in T2 lesion volume. Patients were followed for up to two years or until they fulfilled the primary endpoint.

Eight percent of subjects on BETASERON and 6% of subjects on placebo withdrew from the study for a reason other than the development of a second exacerbation. Time to development of a second exacerbation was significantly delayed in patients treated with BETASERON compared to patients treated with placebo ( $p < 0.0001$ ). The Kaplan-Meier estimates of the percentage of patients developing an exacerbation within 24 months were 45% in the placebo group and 28% of the BETASERON group ([Figure 2](#)). The risk for developing a second exacerbation in the BETASERON group was 53% of the risk in the placebo group (Hazard ratio= 0.53; 95% confidence interval 0.39 to 0.73).

#### **Figure 2: Onset of Second Exacerbation by Time in Patients with Isolated Demyelinating Event with Typical MS Lesions on Brain MRI in Study 4\***

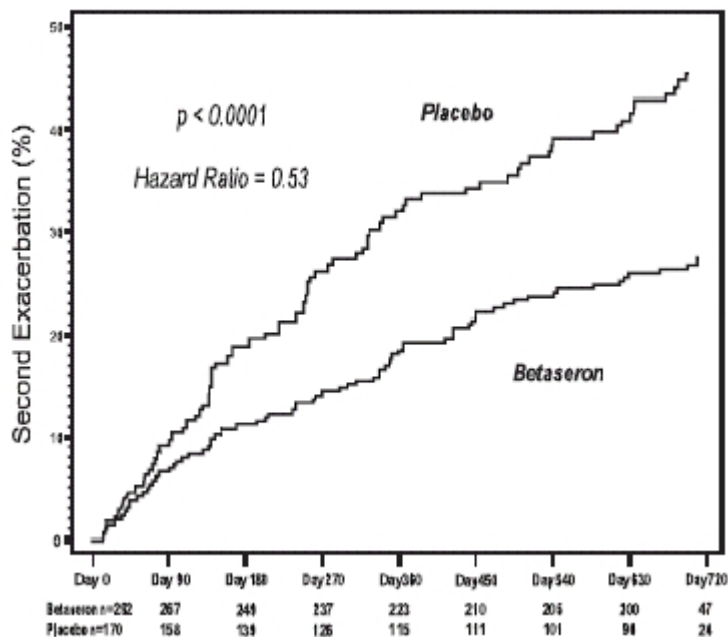

\*Kaplan-Meier Methodology

In Study 4, patients treated with BETASERON demonstrated a lower number of newly active lesions during the course of the study. A significant difference between BETASERON and placebo was not seen in the absolute change in T2 lesion volume during the course of the study.

Safety and efficacy of treatment with BETASERON beyond three years are not known.

## 16 HOW SUPPLIED/STORAGE AND HANDLING

### 16.1 How Supplied

BETASERON is supplied as a lyophilized powder in a clear glass, single-use vial (3 mL capacity). Each carton contains 5 single-use cartons (NDC 50419-524-05) or 14 single-use cartons (NDC 50419-524-35).

Each single-use carton contains:

A single-use vial containing 0.3 mg BETASERON (interferon beta-1b)

A pre-filled single-use syringe containing 1.2 mL diluent (Sodium Chloride, 0.54% solution)

A vial adapter with a 30-gauge needle attached

2 alcohol prep pads

The optional BETACONNECT autoinjector is not supplied with BETASERON, but is available for patients with a prescription for BETASERON by calling the BETAPLUS patient support program toll-free number at 1-800-788-1467.

### 16.2 Stability and Storage

BETASERON and the diluent are for single-use only. Discard unused portions. The reconstituted product contains no preservative. Store BETASERON vials at room temperature 68°F to 77°F (20°C to 25°C). Excursions of 59°F to 86°F (15°C to 30°C) are permitted for up to 3 months. After reconstitution, if not used immediately, refrigerate the reconstituted solution and use within three hours. **Do not freeze.**

## 17 PATIENT COUNSELING INFORMATION

See FDA-approved patient labeling (Medication Guide and Instructions for Use).

Instruct patients to carefully read the supplied BETASERON Medication Guide and caution patients not to change the BETASERON dose or schedule of administration without medical consultation.

### *Instruction on Self-Injection Technique and Procedures*

Provide appropriate instruction for reconstitution of BETASERON and methods of self-injection, including careful review of the BETASERON Medication Guide. Instruct patients in the use of aseptic technique when administering BETASERON.

Tell patients not to re-use needles or syringes and instruct patients on safe disposal procedures. Advise patients of the importance of rotating areas of injection with each dose, to minimize the likelihood of severe injection site reactions, including necrosis or localized infection [*see Medication Guide*].

### *Hepatic Injury*

Advise patients that severe hepatic injury, including hepatic failure, has been reported during the use of BETASERON.

Inform patients of symptoms of hepatic dysfunction, and instruct patients to report them immediately to their healthcare provider [*see Warnings and Precautions (5.1)*].

### *Anaphylaxis and Other Allergic Reactions*

Advise patients of the symptoms of allergic reactions and anaphylaxis, and instruct patients to seek immediate medical attention if these symptoms occur [*see Warnings and Precautions (5.2)*].

### *Depression and Suicide*

Advise patients that depression and suicidal ideation have been reported during the use of BETASERON. Inform patients of the symptoms of depression or suicidal ideation, and instruct patients to report them immediately to their healthcare provider [*see Warnings and Precautions (5.3)*].

### *Congestive Heart Failure*

Advise patients that worsening of pre-existing congestive heart failure have been reported in patients using BETASERON.

Advise patients of symptoms of worsening cardiac condition, and instruct patients to report them immediately to their healthcare provider [*see Warnings and Precautions (5.4)*].

### *Injection Site Necrosis and Reactions*

Advise patients that injection site reactions occur in most patients treated with BETASERON, and that injection site necrosis may occur at one or multiple sites. Instruct patients to promptly report any break in the skin, which may be associated with blue-black discoloration, swelling, or drainage of fluid from the injection site, prior to continuing their BETASERON therapy [*see Warnings and Precautions (5.5)*].

### Flu-like Symptom Complex

Inform patients that flu-like symptoms are common following initiation of therapy with BETASERON, and that concurrent use of analgesics and/or antipyretics on treatment days may help ameliorate flu-like symptoms associated with BETASERON use [see *Warnings and Precautions* (5.7) and *Dosage and Administration* (2.4)].

### Seizures

Instruct patients to report seizures immediately to their healthcare provider [see *Warnings and Precautions* (5.8)].

### Pregnancy

Advise patients that BETASERON should not be used during pregnancy unless the potential benefit justifies the potential risk to the fetus [see *Use in Special Population* (8.1)]. Therefore, inform patients that if a pregnancy is considered, or does occur, the risks and benefits of continuing BETASERON should be discussed with their healthcare provider.

<b>Medication Guide</b> <b>BETASERON</b> <b>(bay-ta-seer-on)</b> interferon beta-1b (in-ter-feer-on beta-one-be)
<p><b>What is the most important information I should know about BETASERON?</b> <b>BETASERON can cause serious side effects, including:</b></p> <ul style="list-style-type: none"><li>• <b>liver problems including liver failure.</b> Symptoms of liver problems may include:<ul style="list-style-type: none"><li>• yellowing of your eyes</li><li>• itchy skin</li><li>• nausea or vomiting</li><li>• feeling very tired</li><li>• flu-like symptoms</li><li>• bruising easily or bleeding problems</li></ul>Your healthcare provider will do blood tests to check for these problems while you take BETASERON.</li><li>• <b>serious allergic reactions.</b> Serious allergic reactions can happen quickly and may happen after your first dose of BETASERON or after you have taken BETASERON many times. Symptoms may include difficulty breathing or swallowing, swelling of the mouth or tongue, rash, itching, or skin bumps.</li><li>• <b>depression or suicidal thoughts.</b> Call your healthcare provider right away if you have any of the following symptoms, especially if they are new, worse, or worry you:<ul style="list-style-type: none"><li>• thoughts about suicide or dying</li><li>• new or worse depression</li><li>• new or worse anxiety</li><li>• trouble sleeping (insomnia)</li><li>• acting aggressive, being angry, or violent</li><li>• acting on dangerous impulses</li><li>• hallucinations</li><li>• other unusual changes in behavior or mood</li></ul></li></ul>
<p><b>What is BETASERON?</b> BETASERON is a prescription medicine used to reduce the number of relapses in people with relapsing forms of multiple sclerosis (MS). This includes people who have had their first symptoms of multiple sclerosis and have an MRI consistent with multiple sclerosis. BETASERON is similar to certain interferon proteins that are produced in the body. It will not cure your MS but may decrease the number of flare-ups of the disease. It is not known if BETASERON is safe and effective in children.</p>
<p><b>Who should not take BETASERON?</b> <b>Do not take BETASERON if you</b> are allergic to interferon beta-1b, to another interferon beta, to human albumin, or mannitol. See the end of this leaflet for a complete list of ingredients in BETASERON</p>
<p><b>What should I tell my healthcare provider before taking BETASERON?</b> <b>Before you take BETASERON, tell your healthcare provider if you:</b></p> <ul style="list-style-type: none"><li>• have or have had depression (sinking feeling or sadness), anxiety (feeling uneasy, nervous, or fearful for no reason) or trouble sleeping</li><li>• have or have had liver problems</li><li>• have or have had blood problems such as bleeding or bruising easily, low red blood cells (anemia) or low white blood cells</li><li>• have or have had seizures</li><li>• have or have had heart problems</li><li>• are pregnant or plan to become pregnant. BETASERON can harm your unborn baby. BETASERON may cause you to lose your baby (miscarry). If you become pregnant while taking BETASERON call your healthcare provider right away. You and your healthcare provider should decide if you should continue to take BETASERON.</li></ul>

- are breastfeeding or plan to breastfeed. It is not known if BETASERON passes into your breast milk. You and your healthcare provider should decide if you will take BETASERON or breastfeed. You should not do both.

**Tell your healthcare provider about all the medicines you take**, including prescription and nonprescription medicines, vitamins, and herbal supplements.

Know the medicines you take. Keep a list of them to show your healthcare provider and pharmacist when you get a new medicine.

#### **How should I take BETASERON?**

- See the Instructions for Use at the end of this Medication Guide for complete information on how to use BETASERON.
- BETASERON is given by injection under your skin (subcutaneous injection) every other day.
- Take BETASERON exactly as your healthcare provider tells you to take it.
- If your healthcare provider feels that you or someone else may give you the injections then you or the other person should be trained by your healthcare provider in how to give an injection.
- Do not try to give yourself or have another person give you injections until you or both of you understand and are comfortable with how to prepare your dose and give the injection.
- You may be started on a lower dose when you first start taking BETASERON. Your healthcare provider will tell you what dose of BETASERON to use.
- Your healthcare provider may change your dose of BETASERON. You should not change your dose without talking to your healthcare provider.
- If you miss a dose, you should take your next dose as soon as you remember or are able to take it. Your next injection should be taken about 48 hours (2 days) after that dose. **Do not** take BETASERON on 2 consecutive days. If you accidentally take more than your prescribed dose, or take it on 2 consecutive days, call your healthcare provider right away.
- **Always use a new, unopened vial of BETASERON and pre-filled diluent syringe for each injection.** Throw away any unused medicine. **Do not** re-use any vials, syringes, or needles.
- It is important for you to change your injection site each time you inject BETASERON. This will lessen the chance of you having a serious skin reaction at the site where you inject BETASERON. Avoid injecting BETASERON into an area of skin that is sore, reddened, infected or has other problems.

#### **What are the possible side effects of BETASERON?**

**BETASERON may cause serious side effects. Call your healthcare provider right away if you have any of the serious side effects of BETASERON including:**

- **See “What is the most important information I should know about BETASERON?”**
- **heart problems.** BETASERON may worsen heart problems including congestive heart failure. Symptoms of heart problems may include:
  - swollen ankles
  - shortness of breath
  - not being able to lay flat in bed
  - tightness in chest
  - decreased ability to exercise
  - fast heartbeat
  - increased need to urinate at night
- **injection site problems.** Serious skin reactions can happen in some people including areas of severe damage to skin and the tissue below the skin (necrosis). These reactions can happen anywhere you inject BETASERON. Symptoms of injection site problems may include swelling, redness, or pain at the injection site, fluid drainage from the injection site, and breaks in your skin or blue-black skin discoloration.
- **flu-like symptoms.** BETASERON can cause flu-like symptoms including:
  - fever
  - tiredness
  - sweating
  - chills
  - muscle aches when you first start to use itThese symptoms may decrease over time. Taking medicines for fever and pain relief on the days you are using BETASERON may help decrease these symptoms.
- **seizures.** Some people have had seizures while taking BETASERON, including people who have never had seizures before. It is not known if the seizures were related to their MS, to BETASERON, or to a combination of both. If you have a seizure after taking BETASERON call your healthcare provider right away.

The most common side effects of BETASERON include:

- low white blood cell count
- increases in your liver enzymes
- problems sleeping
- headache
- increases in your muscle tension
- weakness
- pain
- rash
- stomach pain

Tell your healthcare provider if you have any side effect that bothers you or that does not go away.

These are not all the possible side effects of BETASERON. For more information, ask your healthcare provider or pharmacist.

**Call your doctor for medical advice about side effects. You may report side effects to FDA at 1-800-FDA-1088.**

#### **How should I store BETASERON?**

- Before mixing, store BETASERON at room temperature between 68°F to 77°F (20°C to 25°C).
- Before mixing, BETASERON may be stored for up to 3 months between 59°F to 86°F (15°C to 30°C).
- After mixing, you can refrigerate BETASERON for up to 3 hours before using. Your BETASERON must be used within 3 hours of mixing even if refrigerated.
- **Do not freeze.**

**Keep BETASERON and all medicines out of the reach of children.**

**General information about the safe and effective use of BETASERON.**

Medicines are sometimes prescribed for purposes other than those listed in a Medication Guide. Do not use BETASERON for a condition for which it was not prescribed. Do not give BETASERON to other people, even if they have the same symptoms that you have. It may harm them.

This Medication Guide summarizes the most important information about BETASERON. If you would like more information, talk with your healthcare provider. You can ask your pharmacist or healthcare provider for information about BETASERON that is written for health professionals.

For more information, go to [www.BETASERON.com](http://www.BETASERON.com) or call BETAPLUS, the BETASERON patient support program, at 1-800-788-1467.

**What are the ingredients in BETASERON?**

**Active ingredient:** interferon beta-1b

**Inactive ingredients:** albumin (human), mannitol

Diluent contains sodium chloride solution.

This Medication Guide has been approved by the U.S. Food and Drug Administration

09/15

**Instructions for Use**

**BETASERON**  
**(bay-ta-seer-on)**

interferon beta-1b  
(in-ter-feer-on beta-one-be)

Read the Instructions for Use that come with your BETASERON before you start using it and each time you get a refill. There may be new information. This leaflet does not take the place of talking to your healthcare provider about your medical condition or treatment. Before you use BETASERON for the first time, make sure your healthcare provider shows you the right way to use it.

**Supplies needed for your BETASERON Injection (See Figure A).**

- 1 single-use carton containing:
  - A vial of BETASERON
  - A pre-filled diluent syringe
  - A vial adapter with a 30-gauge needle attached (in the blister pack)
  - 2 alcohol prep pads

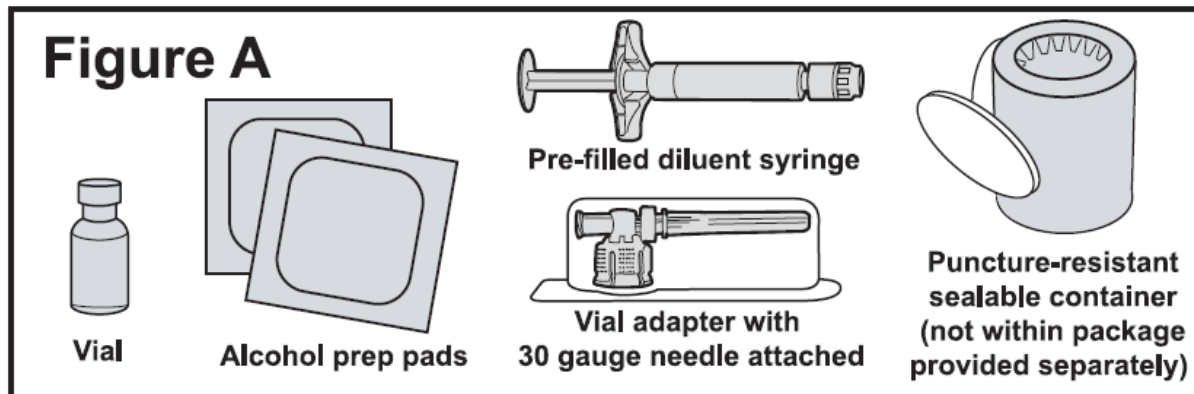

**Step 1: Preparing for Your BETASERON Injection**

- Place the supplies you will need on a clean, flat surface in a well-lit area.

- Check the expiration date on the single-use carton to make sure that it has not expired. **Do not use it if the medication has expired.**
- Wash your hands thoroughly with soap and water.
- Open the single-use carton and take out all the contents. Make sure the blister pack containing the vial adapter is sealed. Check to make sure the plastic cap on the pre-filled diluent syringe is firmly attached.
- Remove the tray from the single-use carton and place it on a flat surface.
- Place the BETASERON vial in the well (vial holder) and place the pre-filled diluent syringe in the U-shaped trough (See Figure B).

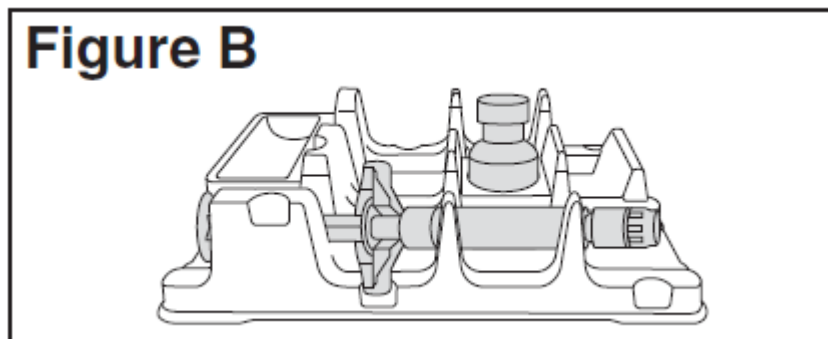

### Step 2: Mixing BETASERON

- Remove the BETASERON vial from the well (vial holder) and take the cap off the vial.
- Place the vial back into the well (vial holder).
- Use an alcohol prep pad to clean the top of the vial. Move the alcohol prep pad in 1 direction. Leave the alcohol prep pad on top of the vial.
- Peel the label off the blister pack with the vial adapter in it. The vial adapter is sterile. Do not remove or touch the vial adapter.
- Remove the alcohol prep pad from the top of the BETASERON vial. Pick up the vial adapter in the blister pack. Turn over the blister pack keeping the vial adapter inside. Put the adapter on top of the BETASERON vial. Push down on the adapter until it pierces the rubber top of the BETASERON vial and snaps in place (See Figure C). Remove the blister packaging from the vial adapter.

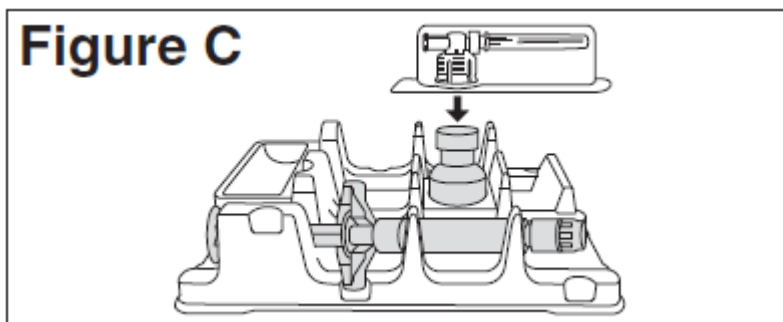

- Twist the plastic cap from the pre-filled diluent syringe. Throw away the plastic cap (See Figure D).

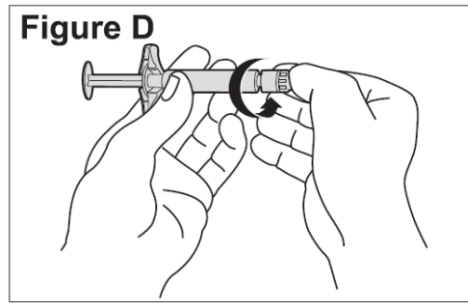

- Keep the vial adapter attached to the vial and remove the vial from the well (vial holder). Be careful not to pull the vial adapter off the top of the vial.
- Connect the pre-filled diluent syringe to the vial adapter by turning clockwise until resistance is felt and the attachment is secure. This forms the syringe assembly (**See Figure E**).

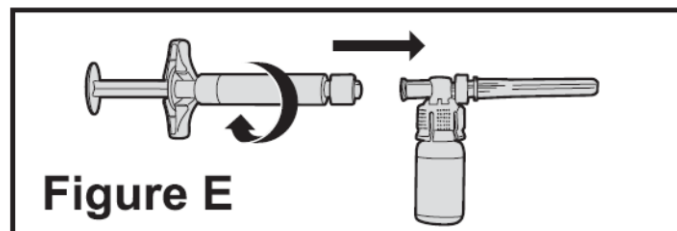

- Slowly push the plunger of the pre-filled diluent syringe all the way in. This will transfer all of the liquid from the syringe into the BETASERON vial (**See Figure F**). The plunger may return to its original position after you release it.

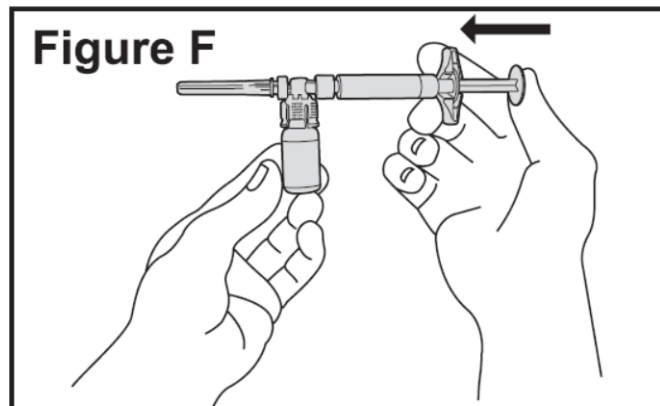

- Gently swirl the vial to completely dissolve the white powder of BETASERON. **Do not shake.** Shaking and even gentle mixing can cause foaming of the medicine. If there is foam, let the vial sit until the foam settles before using it.
- After the powder dissolves, look closely at the solution in the vial. Do not use the solution if it is cloudy or contains particles. It should be clear and colorless.
- Do not use cracked or damaged BETASERON vials. If your vial is cracked or damaged, get a new single-use carton containing a BETASERON vial, pre-filled diluent syringe, vial adapter and 2 alcohol prep pads. Repeat the steps to prepare your BETASERON dose.
- Contact BETAPLUS, the BETASERON patient support program, at 1-800-788-1467 to obtain a replacement product.

### Step 3: Preparing the Injection

You have completed the steps to prepare your BETASERON and are ready for the injection. The injection should be given immediately after mixing and allowing any foam in the solution to settle. If you must wait to give yourself the injection, you may refrigerate the solution and use within 3 hours of mixing your BETASERON. **Do not freeze.**

- Push the plunger in and hold it there; then turn the syringe assembly so that the syringe is horizontal and the vial is on top.
- Slowly pull the plunger back to withdraw all the liquid from the BETASERON vial into the syringe (**See Figure G**).

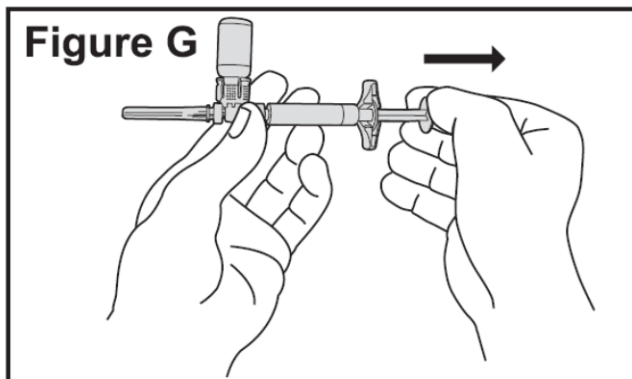

- NOTE: The syringe barrel is marked with numbers from 0.25 mL to 1 mL (**See Figure H**). If the solution in the vial cannot be drawn up to the 1 mL mark, discard the vial and syringe and start over with a new single-use carton containing a BETASERON vial, pre-filled diluent syringe, vial adapter and alcohol prep pads.
- Turn the syringe assembly so that the needle end is pointing up. Remove any air bubbles by tapping the outside of the syringe with your fingers. Slowly push the plunger to the 1 mL mark on the syringe or to the mark that matches the amount of BETASERON prescribed by your healthcare provider (**See Figure H**). If too much solution is pushed into the vial, repeat Step 3.

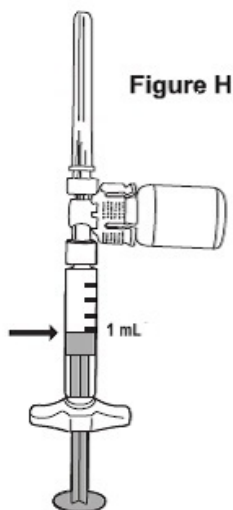

- Turn the syringe assembly so that the vial is at the bottom. Remove the vial adapter and the vial from the syringe by twisting the vial adapter. This will remove the vial adapter and the vial from the syringe, but will leave the needle on the syringe (**See Figure I**).

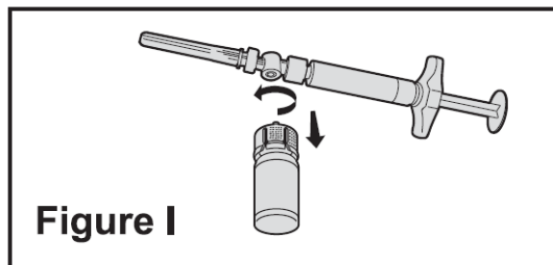

#### Step 4: Choosing an Injection Site

- BETASERON (interferon beta-1b) is injected under the skin and into the fat layer between the skin and the muscles (subcutaneous tissue). The best areas for injection are where the skin is loose and soft and away from the joints, nerves, and bones. **Do not** use the area near your navel or waistline. If you are very thin, use only the thigh or outer surface of the arm for injection.
- Choose a different site each time you give yourself an injection. **Figure J** shows different areas for giving injections. **Do not** inject in the same area for 2 injections in a row. Keep a record of your injections to help make sure you change (rotate) your injection sites. You should decide where you will inject BETASERON before you prepare your medicine for injection. If there are any sites that are difficult for you to reach, you can ask someone who has been trained to give the injection to help you.

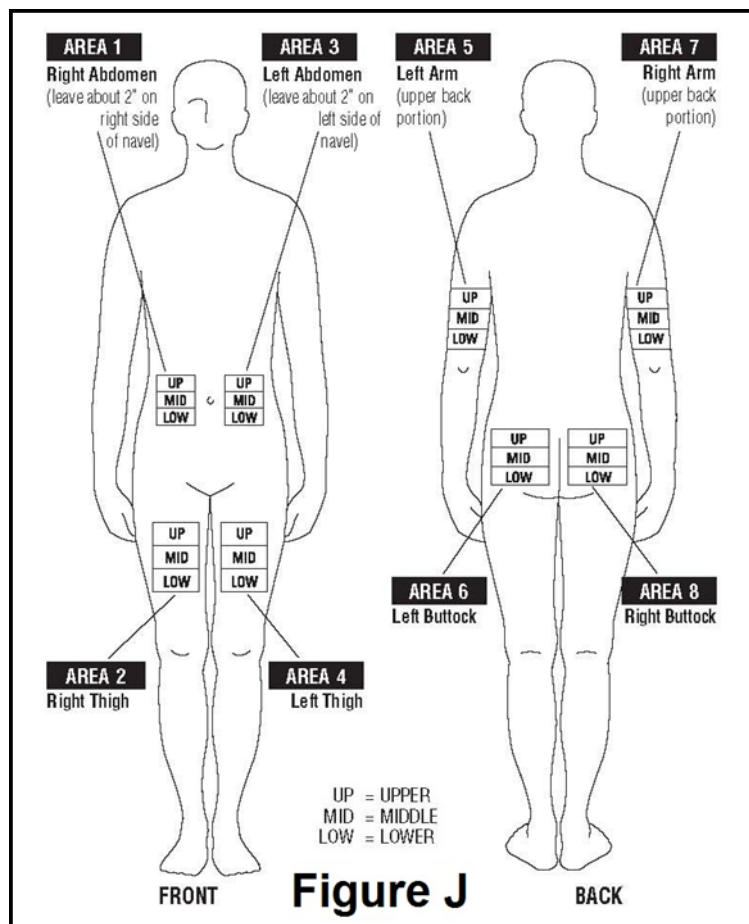

- **Do not** inject BETASERON in a site where the skin is red, bruised, infected, or scabbed, has broken open, or has lumps, bumps, or pain. Tell your healthcare provider if you find skin conditions like the ones mentioned here or any other unusual looking areas where you have been given injections.

### Step 5: Injecting BETASERON

- Using a circular motion, clean the injection site with an alcohol prep pad, starting at the injection site and moving outward. Let the skin area air dry.
- Remove the cap from the needle. Hold the syringe like a pencil or dart in 1 hand.
- Gently pinch the skin around the site with the thumb and forefinger of the other hand (**See Figure K**). Insert the needle straight up and down into your skin at a 90° angle with a quick, dart-like motion.

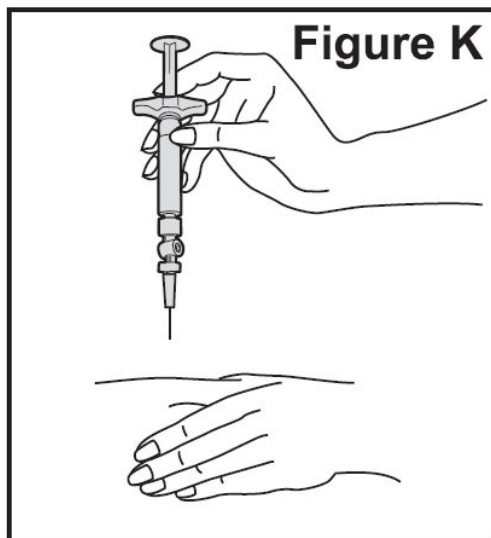

- Slowly push the plunger all the way in until the syringe is empty (**See Figure L**).

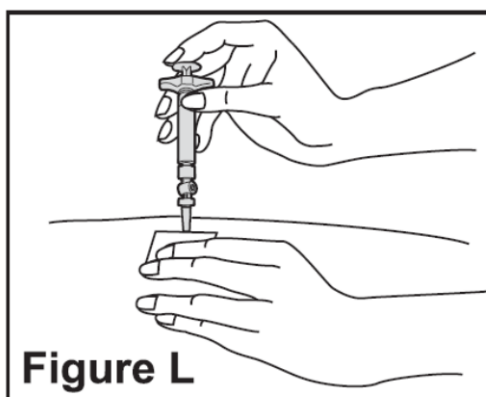

- Remove the needle from the skin. Place a dry cotton ball or gauze pad over the injection site. Gently massage the injection site for a few moments with the dry cotton ball or gauze pad. Throw away the syringe in your puncture-proof disposal container.
- Optional Use of BETACONNECT Autoinjector:  
You may also give BETASERON by using the BETACONNECT autoinjector. You should get help with training on the use of the BETACONNECT autoinjector from a healthcare provider before using it for the first time. The BETACONNECT autoinjector should only be used with the syringes that come in the BETASERON packaging. See the Instructions for Use that come with the BETACONNECT autoinjector. For more information, call BETAPLUS, the BETASERON patient support program, at 1-800-788-1467.

### Step 6: Disposing of used syringes, needles, and vials

- To prevent needle-stick injury and spread of infection, do not try to re-cap the needle.

- Place used needles, syringes, and vials in a closeable, puncture-resistant container. You may use a sharps container (such as a red biohazard container), hard plastic container (such as a detergent bottle), or metal container (such as an empty coffee can). Do not use glass or clear plastic containers. Ask your healthcare provider for instructions on the right way to throw away (dispose of) the container. There may be state and local laws about how you should throw away used needles and syringes.
- **Do not throw used needles, syringes, or vials in your household trash or recycle.**
- Throw away any unused medicine. Do not save any unused BETASERON for a future dose.
- Keep the disposal container, needles, syringes, and vials of BETASERON out of the reach of children.

This Instructions for Use has been approved by the U.S. Food and Drug Administration

09/15

Manufactured for:

Bayer HealthCare Pharmaceuticals Inc.  
Whippany, NJ 07981

Manufactured in Germany

U.S. License No. 1778

© 1993 Bayer HealthCare Pharmaceuticals Inc. All rights reserved.

Revision Date: September 2015

# BETACONNECT™ autoinjector

## Instructions For Use

Language: English

<b>CHAPTER 1: GETTING TO KNOW YOUR BETACONNECT AUTOINJECTOR</b> .....	<b>3</b>
1.1. Getting started.....	3
1.2. Features of your BETACONNECT autoinjector .....	3
1.3. Only use the syringe and 30-gauge needle that come with your BETASERON .....	4
<b>CHAPTER 2: CARING FOR YOUR BETACONNECT AUTOINJECTOR</b> .....	<b>5</b>
2.1 Charging your BETACONNECT autoinjector .....	5
2.2 Cleaning your BETACONNECT autoinjector .....	5
<b>CHAPTER 3: INJECTING WITH YOUR BETACONNECT AUTOINJECTOR</b> .....	<b>6</b>
3.1 Preparing your BETACONNECT autoinjector .....	6
3.2 Injection steps .....	7
3.3 Removing the used syringe and needle.....	10
<b>CHAPTER 4: MAKING SETTING ADJUSTMENTS</b> .....	<b>11</b>
4.1. Adjusting the injection depth.....	11
4.2. Adjusting the injection speed.....	11
4.3. Setting the injection reminder.....	12
<b>CHAPTER 5: TROUBLESHOOTING</b> .....	<b>13</b>
<b>CHAPTER 6: TECHNICAL SPECIFICATIONS</b> .....	<b>15</b>
6.1 Symbols.....	15

**Important Information about your BETACONNECT autoinjector:**

- Only use prepared BETASERON syringes for your injection with the BETACONNECT autoinjector. See the Instructions for Use for BETASERON for how to prepare and measure your dose of BETASERON for use in the BETACONNECT autoinjector.
- If this is your first BETASERON injection, it should be given under the supervision of a healthcare provider.
- Before you use the BETACONNECT autoinjector for the first time, make sure you get help with appropriate training on its use from a healthcare provider.

Read these instructions before you use the BETACONNECT autoinjector for the first time. Keep these instructions in a safe place.



**Warning!**

Whenever you see this symbol it means that safety instructions must be followed.

**If you have questions about your BETACONNECT, call BETAPLUS® at 1-800-788-1467 to talk with a BETA Nurse.**

- **Do not** use the BETACONNECT if:
  - The prefilled syringe cannot be inserted or removed from the BETACONNECT autoinjector according to the instructions.
  - The syringe was not completely emptied during the last time you tried to use BETACONNECT. (If the injection has been stopped, the syringe will not be completely emptied.)
  - Unexpected events happen, or the BETACONNECT does not operate as described in these Instructions For Use.
- Keep BETACONNECT away from heat or fire. Keep it out of direct sunlight.
- Keep BETACONNECT and its accessories, including cables, out of reach of children. Playing with the cables can lead to strangulation.
- **Do not** use BETACONNECT if, during normal use or during recharging, it does not work as expected or if it appears to be damaged. If this happens, call BETAPLUS at 1-800-788-1467 and speak with a BETA Nurse.
- **Do not** use BETACONNECT in areas with high oxygen levels, such as when supplemental oxygen is in use.
- BETACONNECT is not watertight. Keep it dry. Do not place it in liquid.
- Use your BETACONNECT only with the 30-gauge needles and syringes that come with your BETASERON® (interferon beta-1b).
- Remember that the syringes are made of glass and can break if dropped or hit too hard.
- Only inject into bare skin. **Do not** inject through your clothes.
- To avoid risk of infection, **do not** share your BETACONNECT with another person.
- **Do not** point your BETACONNECT at another person or at yourself except when you are ready to inject.
- Seeing or hearing impaired patients should use BETACONNECT only with the help of a caregiver who is trained to use it.
- Use the built-in reminder only as a backup. You still must take BETASERON on schedule, every other day, and follow the instructions from your healthcare provider even if you use the built-in reminder.
- BETACONNECT is an electronic device. Handle it with care.
- **Do not** change or modify this equipment. **Do not** try to open or repair BETACONNECT. The batteries are not replaceable.
- **Do not** wash BETACONNECT in a dishwasher.
- The safety release is located at the tip of BETACONNECT. It is important to keep the safety release clean. Use a dry or slightly damp cloth or an alcohol wipe.
- If BETACONNECT is exposed to extreme vibration, pressure, or shock (such as being dropped or stepped on), it may be damaged. Check to see that it is working normally.
- BETACONNECT contains rechargeable batteries.
- Use only the charger and cables that came with BETACONNECT. Other cables may create problems or interfere with other electronic devices.
- BETACONNECT cannot be used for injection while charging. Recharge at a temperature between 50°F and 95°F (10°C to 35°C).

## Chapter 1: Getting to Know Your BETACONNECT autoinjector

### 1.1. Getting started

The shipment box contains the following items:

- BETACONNECT™ autoinjector
- Storage case
- Charger
- Micro USB cable
- Quick Start Guide
- BETACONNECT autoinjector Instructions For Use (IFU)

Your BETASERON will arrive in a separate shipment from your pharmacy.

#### Supplies needed for your BETACONNECT Injection

- BETACONNECT autoinjector
- prepared BETASERON syringe with attached capped needle (See Instructions for Use for BETASERON Prefilled Syringe)
- alcohol prep pad
- puncture resistant sharps container for throwing away used needles and syringes. (See “Disposing of used needles and syringes” at the end of these Instructions for Use.)

**Important:** Before you use your BETACONNECT for the first time, you need to charge it fully. Plug the small end of the micro USB cable into your BETACONNECT and the large end into the charger. Plug the charger into a power outlet, and let it charge for about 2 hours. When you see four green bars, BETACONNECT is fully charged.

### 1.2. Features of your BETACONNECT autoinjector

Check with your healthcare provider before using your BETACONNECT for the first time. Use your BETACONNECT to help you take your BETASERON as prescribed. Remember to change your injection sites each time you inject the medicine as shown in the BETASERON Medication Guide. You will need to prepare the syringe that comes with your BETASERON, and place it in the BETACONNECT autoinjector as shown in the instructions.

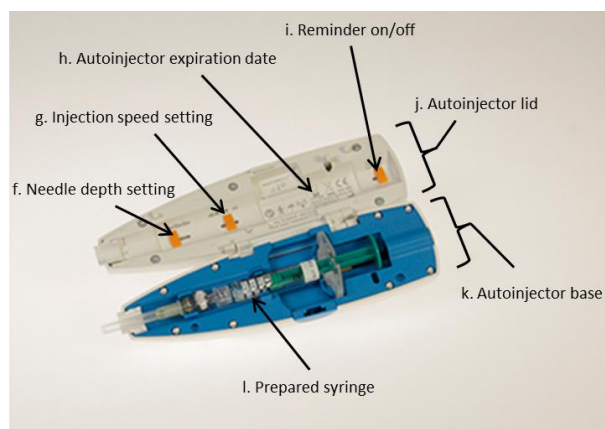
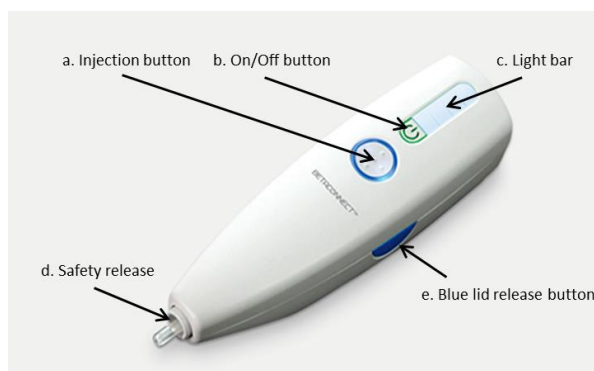

- Injection button:** Press and release the injection button to start the injection. The injection button flashes blue when the safety is released. There is no need to keep the button pressed during the injection process.
- On/off button:** Use the on/off button to turn BETACONNECT on and off. If the on/off button blinks green continuously, or the light bar blinks red, see chapter 5, “Troubleshooting.”

- c. **Light bar:** Because the injection procedure is quiet, the light bar shows the progress of your injection. BETACONNECT will also sound 2 short beeps and show a blue, flashing bar once the injection is complete and the needle is withdrawn.
- d. **Safety release:** When you are ready to inject, activate the safety release by gently holding BETACONNECT against the skin at a 90° angle (straight up and down). It is important to keep the safety release clean.
- e. **Blue lid release button:** Use to open the lid.
- f. **Needle depth setting:** BETACONNECT allows you to adjust needle insertion depths to 12, 10, or 8 mm. Before making any adjustments, read section 4.1, “Adjusting the injection depth,” and talk with your BETA Nurse or healthcare provider.
- g. **Injection speed setting:** BETACONNECT allows you to set your injection speed at slow, medium, or fast. Before you make any changes to the speed, read section 4.2, “Adjusting the injection speed.”
- h. **Autoinjector expiration date:** BETACONNECT comes with an expiration date, to show that the device should not be used after the end of the year (YYYY) and month (MM), printed as YYYY-MM.
- i. **Reminder on/off switch:** Use the built-in reminder if you want your BETACONNECT to let you know that it has been 48 hours (2 days) since your last injection. When it is time for your next injection, you should hear a beep and see a flashing light. If you do not want to use the reminder, you can turn it off. See section 4.3, “Setting the injection reminder.” Make sure you follow the injection schedule given to you by your healthcare provider.
- j. **Autoinjector lid:** You can open the lid by pressing the blue lid release button.
- k. **Autoinjector base:** The base is the part of the autoinjector that holds the prepared BETASERON syringe
- l. **Prepared syringe:** Use only the syringes that come with your BETASERON. Remember to refer to the BETASERON® (interferon beta-1b) Medication Guide for instructions on how to prepare your syringe. When you insert a prepared syringe, make sure that it is lined up with the syringe outline in the insertion area.

**Signals:** The BETACONNECT autoinjector:

- Lets you know when it needs recharging. To save battery power, it will automatically power down if not in use for 20 minutes.
- Reminds you when it is time for your next injection with a beep and a flashing light. (If you do not want to use the reminder, you can turn it off using the toggle switch inside the cover.)

### 1.3. Only use the syringe and 30-gauge needle that come with your BETASERON



BETACONNECT is designed to inject between 0.25 and 1 mL of reconstituted BETASERON, using the syringe and the 30-gauge needle that come with your medicine. Prepare your syringe as shown in the BETASERON Medication Guide. Call BETAPLUS® at **1-800-788-1467** if you need help preparing your injection or have any questions.

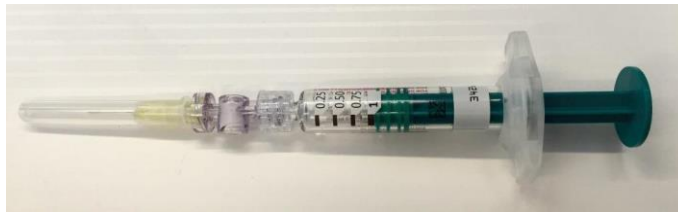

## Chapter 2: Caring for Your BETACONNECT autoinjector

### 2.1 Charging your BETACONNECT

**Important:** BETACONNECT must be fully charged before first-time use.

**Do not** use BETACONNECT while it is charging.

Step 1: Connect the supplied micro-USB cable and charger.



To charge the BETACONNECT autoinjector, plug the micro USB cable into the charger and into your BETACONNECT. Plug the charger into a power outlet, and let it charge for about 2 hours.

A full charge will help make sure that BETACONNECT is ready when you are. A full charge should last for between 15 to 20 injections, or for 4 to 5 weeks.

Step 2: Checking your charge status



4 green bars mean that BETACONNECT is fully charged. After receiving a full charge, your BETACONNECT will turn off.

### 2.2 Cleaning your BETACONNECT autoinjector

- Always store BETACONNECT with the lid closed and in its plastic storage case to help protect it from dust, dirt, extreme temperatures, or direct sunlight.
- It is important to keep the safety release clean. Use a dry or slightly damp cloth or an alcohol wipe.
- If medicine is spilled inside BETACONNECT, remove it right away using a damp cloth.
- Other parts of BETACONNECT do not normally need to be cleaned. If needed, lightly dampen a cloth with water and wipe the device.
- Never place BETACONNECT in any liquid. **Do not** try to clean it in a dishwasher.

## Chapter 3: Injecting With Your BETACONNECT autoinjector

**Important:** Before you use your BETACONNECT for the first time, you need to charge it fully; 4 green bars mean your BETACONNECT is fully charged.

### 3.1 Preparing your BETACONNECT

#### Step 1: Turn your BETACONNECT on



Remove the fully charged BETACONNECT from its plastic storage case. Press the on/off button:

- A short beep will tell you that BETACONNECT is turned on.

Wait for the power-on self-test to finish (it takes only a few seconds). When BETACONNECT is ready, the injection button will glow blue and the green light bar will show your charge status.

- If the on/off button blinks green continuously, or the light bar blinks red, see chapter 5, "Troubleshooting."

#### Step 2: Check your charge



Check the charge status on the light bar:

- 4 green bars indicate that the battery is fully charged.
- If only 1 green bar is flashing, there is enough power for an injection, but the BETACONNECT must be recharged afterwards.
- A flashing orange bar means that the battery level is too low to perform an injection. BETACONNECT will shut off, and you will need to charge it before you can inject.

#### Step 3: Open the lid



Press the blue lid release button on the side of the BETACONNECT, and fully open the lid.

**Important:** Remember to refer to the BETASERON<sup>®</sup> (interferon beta-1b) Medication Guide for instructions on how to prepare your syringe.

**Step 4: Insert the syringe into your BETACONNECT**



When you have prepared a syringe, leave the needle cap on. Gently fit the syringe into the molded syringe outline in the BETACONNECT autoinjector base until it snaps into place.

- The syringe must be lined up with the syringe outline.
- The lid will not close if the syringe is not seated properly.
- Check that your depth and speed settings are correct. (For depth and speed setting see chapter 4, "Making Adjustments.")

**Step 5: Close the lid and check the injection button**



Close the lid. You will hear a click when it shuts.

- When the injection button shows a steady blue light this means that BETACONNECT is now ready to be used for an injection.
- The lid must be fully closed to administer an injection.

### 3.2 Injection steps

#### Supplies needed for your BETACONNECT Injection

- BETACONNECT autoinjector
- prepared BETASERON syringe with attached capped needle (See Instructions for Use for BETASERON Prefilled Syringe)
- alcohol prep pad
- puncture resistant sharps container for throwing away used needles and syringes. (See "Disposing of used needles and syringes" at the end of these Instructions for Use.)

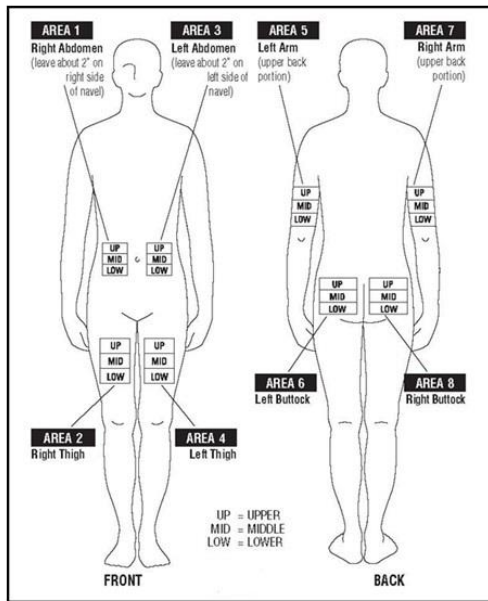

BETASERON is injected under the skin and into the fat layer between the skin and the muscles (subcutaneous tissue). The best areas for injection are where the skin is loose and soft and away from the joints, nerves, and bones such as the stomach (abdomen), upper arm, thigh or buttock. **Do not** use the area near your navel or waistline. If you are very thin, use only the thigh or outer surface of the arm for injection. Choose a different site each time you give yourself an injection. **Do not** inject in the same area for 2 injections in a row.

#### Step 1: Clean the injection site

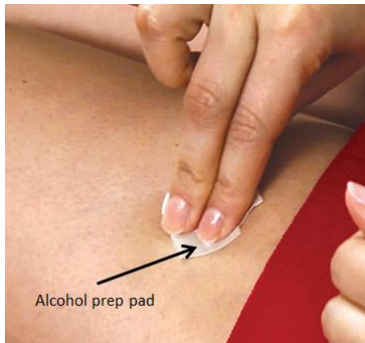

Clean the injection site with an alcohol prep pad using a circular motion. Start at the injection site and move outward. Let the skin area air dry.

#### Step 2: Remove the needle cap



Remove the needle cap by pulling it off at the front of the BETACONNECT. **Do not** twist the needle cap when removing it.

**Important:** Be careful not to accidentally press the injection button while removing the needle cap

**Step 3: Place the BETACONNECT autoinjector against the injection site**



Gently hold the BETACONNECT against the skin at a 90° angle (straight up and down) to activate the safety release.

- The injection button flashes blue when the safety is released.
- Make sure you hold the BETACONNECT against your skin for the entire injection.

**Important:** When BETACONNECT is in “ready” or “inject” mode with a syringe inside, take special care not to accidentally press the injection button.

**Step 4: Start the injection**



Press and release the injection button to start the injection.

- There is no need to keep the button pressed during the injection process.

**Step 5: Check the injection status**



The lit blue bar goes down in stages as the injection progresses.

**Do not interrupt the injection.**  
**The injection cycle will be interrupted if you:**

- Press the on/off button before the injection is complete.
- Remove your BETACONNECT from the injection site before the injection is complete.



If the injection is stopped before your injection is complete you will see a blinking red light.

Check to make sure you received your full dose. If you did not receive your full dose, call your BETA Nurse or healthcare provider.

**Important:** The injection procedure is quiet. Use the light bar to check the injection status.

Always hold BETACONNECT straight up and down. Keep it pressed against your injection site for as long as the injection lasts.

Step 6: When the injection is finished



BETACONNECT will sound 2 short beeps and show a blue, flashing bar after the injection is complete and the needle is withdrawn.

**Do not remove BETACONNECT from the injection site until the injection is complete.**

- BETACONNECT will automatically power down once the injection is complete.

### 3.3 Removing the used syringe and needle

Step 1: Open the lid



Press the blue lid release button on the side of the BETACONNECT, and fully open the lid.

Step 2: Remove the used syringe



Remove the syringe by gently lifting it straight out of the BETACONNECT.

- Hold BETACONNECT with your other hand while removing the syringe. Check the syringe to be sure the entire dose was delivered.

**Important:** Take care to avoid the needle when you remove the empty syringe. It could injure you or others.

Do not put the needle cap back on the syringe.

Always dispose of your empty syringe promptly, using an appropriate sharps container.

Step 3: Disposing of Used Needles and Syringes

Put your used BETASERON syringe and needle in a FDA-cleared sharps disposal container right away after use.

- **Do not throw away (dispose of) your used syringes and needles in your household trash.**
- If you do not have a FDA-cleared sharps disposal container, you may use a household container that is:
  - made of a heavy-duty plastic
  - can be closed with a tight-fitting, puncture-resistant lid, without sharps being able to come out
  - upright stable during use
  - leak-resistant
  - properly labeled to warn of hazardous waste inside the container
- When your sharps disposal container is almost full, you will need to follow your community guidelines for the right way to dispose of your sharps disposal container. There may be state or local laws about how you should dispose of used syringes. For more information about the safe sharps disposal, and for specific information about sharps disposal in the state that you live in, go to the FDA's website at: <http://www.fda.gov/safesharpsdisposal>.
- Do not dispose of your used sharps disposal container in your household trash unless your community guidelines permit this. Do not recycle your used sharps disposal container.  
**Keep the disposal container out of the reach of children.**

## Chapter 4: Making Setting Adjustments

### 4.1. Adjusting the injection depth

**Important:** Talk with your BETA Nurse or healthcare provider before you change your injection settings.

#### Step 1: Open the lid fully



Press the blue lid release button to open the lid.

You can set injection depths of 12, 10, or 8 mm by moving the injection depth slider.

When you receive BETACONNECT, it is set to the injection depth of 12 mm. Ask your healthcare provider if you should use a different depth before changing.

#### Step 2: Set the depth slider to the desired setting



To adjust the injection depth:

- 12 mm: Move the slider to the 12-mm setting.
- 10 mm: Move the slider to the 10-mm setting.
- 8 mm: Move the slider to the 8-mm setting.

### 4.2. Adjusting the injection speed

**Important:** Talk with your BETA Nurse or healthcare provider before you change your injection settings.

Step 1: Open the lid fully

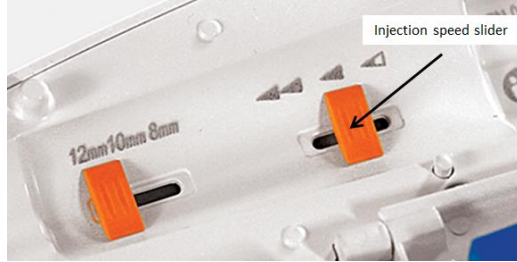

Press the blue lid release button to open the lid.

The setting allows for a slow, medium, or fast injection.

When you receive BETACONNECT, it is set to the medium injection speed. Ask your healthcare provider if you should use a different injection setting before changing.

Step 2: Set the injection speed slider to the desired setting



To adjust the injection speed:

Fast: Move slider to ◀◀ symbol.

Medium: Move slider to ◀ symbol.

Slow: Move slider to ◀◀◀ symbol.

### 4.3. Setting the injection reminder

Step 1: Open the lid all the way



Press the blue lid release button to open the lid.

The BETACONNECT will alert you when 48 hours (2 days) have passed since your last injection. The reminder automatically resets after each injection.

When it is time for your next injection, you should hear a beep and see a blue flashing light. The light will flash for 1 hour, and the beep will sound 1 time every 15 minutes for 1 hour.

The reminder is turned on (enabled) when you receive BETACONNECT. If you do not want to use it, you will need to turn it off using the switch shown at left.

- Use the built-in reminder only as a backup. You still must take BETASERON on schedule, every other day, and follow the instructions from your healthcare provider even if you use the built-in reminder.

**Step 2: Set the reminder function**



To set the reminder:

On, move the slider to 

Off, move the slider to 

**Step 3: When the reminder goes off**



Your BETACONNECT will begin to beep and the top of the blue light bar will flash to remind you when it is time to inject.

- The flashing light reminder lasts for 1 hour.
- The beep occurs every 15 minutes for 1 hour.
- You can mute the beep and still have the flashing light reminder by pressing the injection button or opening the lid.
- To cancel both the beep and the flashing light reminder, press the on/off button.

## Chapter 5: Troubleshooting

If you need assistance setting up, using, or maintaining your BETACONNECT autoinjector, talk with your BETA Nurse or healthcare provider, or call BETAPLUS® at 1-800-788-1467 anytime.

Problem	Cause	Solution
<b>Unable to turn the BETACONNECT autoinjector on by pressing the on/off button</b>	1. On/off button was not pressed long enough.	1. Firmly press the on/off button for more than 2 seconds.
	2. Battery is not charged.	2. Recharge the BETACONNECT autoinjector.
	3. Battery or electronic failure.	3. Contact your BETA Nurse for a replacement.
<b>BETACONNECT autoinjector turns off automatically</b>	1. BETACONNECT autoinjector will automatically turn off after 20 minutes of inactivity.	1. Press the on/off button to turn on.





Problem	Cause	Solution
	2. BETACONNECT autoinjector will power off if the battery level is too low.	2. Recharge your BETACONNECT autoinjector if the battery indicator flashes orange when you turn your device on.
<b>Unable to use the BETACONNECT autoinjector while it is being charged</b>	1. The BETACONNECT autoinjector will not operate while it is being charged.	1. Fully charge the BETACONNECT autoinjector and remove the charger before use.
<b>Unable to open the lid</b>	1. The lid cannot be opened during the injection process.	1. Wait until the injection process is completed.
	2. The lid or the blue lid release button does not function.	2. Ask your BETA Nurse or healthcare provider for a replacement.
<b>Unable to inject while the safety release is activated</b>	1. The safety release does not function.	1. Ask your BETA Nurse or healthcare provider for a replacement.
<b>Unable to charge the BETACONNECT autoinjector</b>	1. The wrong micro-USB cable or charger is used.	1. Make sure you use the charger and cables that come with your BETACONNECT autoinjector.
	2. The micro-USB connection is worn out.	2. Ask your BETA Nurse or healthcare provider for a replacement.
<b>Unable to insert the syringe into the BETACONNECT autoinjector</b>	1. The wrong syringe type is used.	1. Use only the syringes that come with your BETASERON.
	2. The syringe is not placed into the insertion area correctly.	2. Make sure that the syringe is lined up with the syringe outline in the insertion area.
	3. The syringe is not prepared correctly.	3. Refer to the instructions in the BETASERON Medication Guide, and prepare a new syringe if necessary.
	4. The plunger is pulled past the 1 mL mark.	4. Adjust the plunger to the 1 mL mark, or the dose prescribed to you by your healthcare provider.
<b>The green light on the on/off button does not stop blinking after the BETACONNECT autoinjector was turned on</b>		1. The self-test is not completed.
		1. Make sure the safety release in the front of the BETACONNECT autoinjector is not pressed.
		2. Open the lid and close the lid. Make sure the lid is fully closed.
		3. Make sure no buttons are pressed down.
4. Hold the on/off button to shut down BETACONNECT autoinjector, and turn it on again. If the problem is not solved, contact your BETA Nurse or healthcare provider.		
<b>A red blinking light is shown on the BETACONNECT autoinjector</b>	1. The injection procedure was interrupted.	1. If the injection was interrupted, check to see that the entire dose was injected. If it was not, talk with your BETA Nurse or healthcare





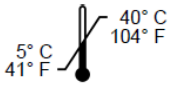

Problem	Cause	Solution
		provider.
	2. A malfunction was detected.	2. Hold the on/off button down to shut down BETACONNECT autoinjector and turn it on again.  If the red blinking light is still there, talk with your BETA Nurse or healthcare provider.
<b>An orange light is shown on the BETACONNECT autoinjector during charging</b>	1. The temperature is too low or too high for charging.	1. The BETACONNECT can be recharged at a temperature from 50°F to 95°F (10°C to 35°C).



### 6.1 Symbols

The following symbols are used on your BETACONNECT autoinjector and its packaging.

	It is important that you read these instructions before you use the BETACONNECT autoinjector.
	The symbol comes with an expiration date to show that the device should not be used after the end of the year (YYYY) and month (MM), printed as YYYY-MM. Ask your BETA Nurse or Healthcare provider for a replacement.
	Keep your BETACONNECT autoinjector dry.
	The BETACONNECT autoinjector can be <b>operated</b> at a temperature from 41°F to 104 °F (5°C to 40°C), at a humidity level of 15% to 93% relative humidity, not condensing, and an atmospheric pressure range of 700 hPa to 1,060 hPa (525 mm Hg to 795 mm Hg).
	The BETACONNECT can be <b>stored</b> at a temperature from 14°F to 104 °F (-10°C to 40°C) at a humidity level of 20% to 93% relative humidity, not condensing, and an atmospheric pressure range of 700 hPa to 1,060 hPa (525 mm Hg to 795 mm Hg).
	The BETACONNECT autoinjector contains electrical and electronic components, and must not be disposed of using standard garbage collection. Talk to local authorities about regulations on disposal of electrical and electronic equipment.  Follow local regulations for disposal of electronic waste. To protect natural resources and to promote material reuse, separate packaging material from other types of waste, and recycle the material through your local recycling system.

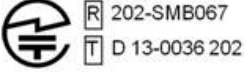
	<p>The BETACONNECT autoinjector is a type BF device, and provides protection against electrical shock and electrical current leakage.</p>
	<p>Manufacturer</p>
	<p>The unique serial number of this BETACONNECT autoinjector.</p>
	<p>The BETACONNECT autoinjector complies with the requirements of The Medical Device Directive (MDD 93/42/EEC), the Radio and Telecommunications Terminal Equipment Directive (R&amp;TTE 1999/5/EC), and the RoHS (Restriction of Hazardous Substances) directive (2011/65/EU).</p>
	<p>The BETACONNECT autoinjector radiates nonionizing electromagnetic signals.</p>
	<p>This device complies with part 15 of the FCC Rules. Operation is subject to the following 2 conditions: (1) This device may not cause harmful interference, and (2) this device must accept any interference received, including interference that may cause undesired operation.</p>
<p>IC: 3775E-BETAC1</p>	<p>The BETACONNECT autoinjector is IC-authorized under the listed grantee code showing compliance to Canadian regulations regarding unlicensed transmissions. This device complies with Industry Canada license-exempt RSS standard(s). Operation is subject to the following 2 conditions: (1) this device may not cause interference, and (2) this device must accept any interference, including interference that may cause undesired operation of the device.</p>
	<p>Japanese Radio Law and Japanese Telecommunications Business Law Compliance. This device is granted pursuant to the Japanese Radio Law (電波法) and the Japanese Telecommunications Business Law (電気通信事業法). This device should not be modified (otherwise the granted designation number will become invalid).</p>

**Expiration and disclaimer**

After the expiration date, your BETACONNECT autoinjector has to be replaced. Ask your BETA Nurse or healthcare provider for a new BETACONNECT autoinjector. The expiration date can be located inside the lid indicated by year (YYYY) and month (MM) printed as YYYY-MM. **Do not** use your BETACONNECT autoinjector after the expiration date.

If you have any questions about BETASERON, contact your BETA Nurse at **1-800-788-1467**, or read the Medication Guide and full Prescribing Information for BETASERON.

Talk with your BETA Nurse or healthcare provider:

- If you have any questions about your BETACONNECT
- If you do not need it anymore and want to dispose of it
- If your BETACONNECT does not work the right way or if unexpected events happen.

Manufactured by  
Medicom Innovation Partner a/s  
Gimsinglundvej 20

This label may not be the latest approved by FDA.  
For current labeling information, please visit <https://www.fda.gov/drugsatfda>

DK-7600 Struer  
Denmark

This Instructions for Use has been approved by the U.S. Food and Drug Administration

09/15

## BETACONNECT™ autoinjector Quick Guide

### Overview

**Information:** Use only a prepared BETASERON® syringe with attached capped needle.

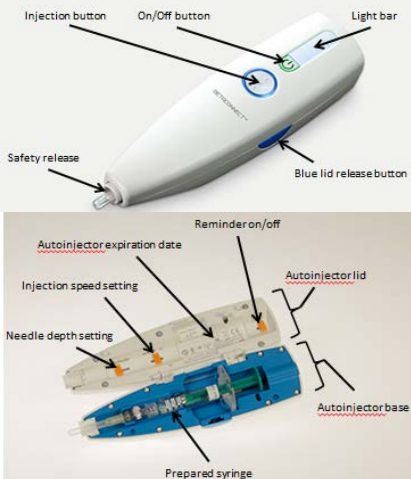

### Injection Process

The injection procedure is quiet. Do not remove BETACONNECT from the injection site until the device has shown that the injection is complete.

#### Step 1:

Press the **on/off button** to turn on the BETACONNECT.



#### Step 2:

Push the blue lid release button to open the lid.

#### Step 3:

Place the syringe in the BETACONNECT base until it snaps into place.



**Step 4:**  
Close the lid.

**Step 5:**  
Remove needle cap.

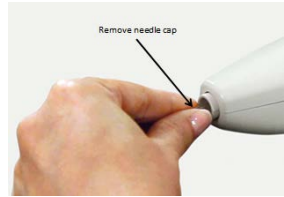

**Step 6:**  
Choose an injection site such as the stomach (abdomen), upper arm, thigh, or buttock. Change the injection site each time you give your injection.

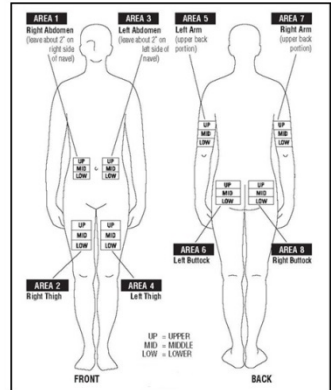

**Step 7:**  
Clean the injection site with an alcohol prep pad using a circular motion starting from the injection site and moving outward. Let the skin dry.



**Step 8:**  
Place the BETACONNECT Autoinjector against the skin at a 90° angle (straight up and down).

**Step 9:**  
Press the injection button to start the injection.



**Step 10:**  
The lit blue bar will go down in stages as the injection progresses. Injection is complete when you hear short beeps and the light bar flashes blue.



**Only remove the BETACONNECT from the injection site once the BETACONNECT has**

**This label may not be the latest approved by FDA.  
For current labeling information, please visit <https://www.fda.gov/drugsatfda>**

**indicated that the injection is complete. Four blue  
reducing illuminated lights show the injection  
status. Injection is complete when you hear short  
beeps and the light bar flashes blue.**

Version: 09/15

Manufactured by

Medicom Innovation Partner a/s  
Gimsinglundvej 20  
DK-7600 Struer  
Denmark