

HIGHLIGHTS OF PRESCRIBING INFORMATION

These highlights do not include all the information needed to use STELARA® safely and effectively. See full prescribing information for STELARA®.

STELARA® (ustekinumab) injection, for subcutaneous or intravenous use

Initial U.S. Approval: 2009

RECENT MAJOR CHANGES

Indications and Usage, Ulcerative Colitis (1.4)	10/2019
Dosage and Administration (2.3)	10/2019
Dosage and Administration (2.6)	11/2019
Warnings and Precautions (5.1)	11/2019

INDICATIONS AND USAGE

STELARA® is a human interleukin-12 and -23 antagonist indicated for the treatment of:

Adult patients with:

- moderate to severe plaque psoriasis (Ps) who are candidates for phototherapy or systemic therapy. (1.1)
- active psoriatic arthritis (PsA), alone or in combination with methotrexate. (1.2)
- moderately to severely active Crohn's disease (CD). (1.3)
- moderately to severely active ulcerative colitis. (1.4)

Adolescent patients (12 years or older) with:

- moderate to severe plaque psoriasis, who are candidates for phototherapy or systemic therapy. (1.1)

DOSAGE AND ADMINISTRATION

Psoriasis Adult Subcutaneous Recommended Dosage (2.1):

Weight Range (kilogram)	Dosage Regimen
less than or equal to 100 kg	45 mg administered subcutaneously initially and 4 weeks later, followed by 45 mg administered subcutaneously every 12 weeks
greater than 100 kg	90 mg administered subcutaneously initially and 4 weeks later, followed by 90 mg administered subcutaneously every 12 weeks

Psoriasis Adolescent (12 years and older) Subcutaneous Recommended

Dosage (2.1): Weight based dosing is recommended at the initial dose, 4 weeks later, then every 12 weeks thereafter.

Weight Range (kilogram)	Dosage Regimen
less than 60 kg	0.75 mg/kg
60 kg to 100 kg	45 mg
greater than 100 kg	90 mg

Psoriatic Arthritis Adult Subcutaneous Recommended Dosage (2.2):

- The recommended dosage is 45 mg administered subcutaneously initially and 4 weeks later, followed by 45 mg administered subcutaneously every 12 weeks.
- For patients with co-existent moderate-to-severe plaque psoriasis weighing greater than 100 kg, the recommended dosage is 90 mg administered subcutaneously initially and 4 weeks later, followed by 90 mg administered subcutaneously every 12 weeks.

Crohn's Disease and Ulcerative Colitis Initial Adult Intravenous

Recommended Dosage (2.3): A single intravenous infusion using weight-based dosing:

Weight Range (kilogram)	Recommended Dosage
up to 55 kg	260 mg (2 vials)
greater than 55 kg to 85 kg	390 mg (3 vials)
greater than 85 kg	520 mg (4 vials)

Crohn's Disease and Ulcerative Colitis Maintenance Adult Subcutaneous

Recommended Dosage (2.3): A subcutaneous 90 mg dose 8 weeks after the initial intravenous dose, then every 8 weeks thereafter.

DOSAGE FORMS AND STRENGTHS

Subcutaneous Injection (3)

- Injection: 45 mg/0.5 mL or 90 mg/mL solution in a single-dose prefilled syringe
- Injection: 45 mg/0.5 mL solution in a single-dose vial

Intravenous Infusion (3)

- Injection: 130 mg/26 mL (5 mg/mL) solution in a single-dose vial (3)

CONTRAINDICATIONS

Clinically significant hypersensitivity to ustekinumab or to any of the excipients. (4)

WARNINGS AND PRECAUTIONS

- **Infections:** Serious infections have occurred. Do not start STELARA® during any clinically important active infection. If a serious infection or clinically significant infection develops, consider discontinuing STELARA® until the infection resolves. (5.1)
- **Theoretical Risk for Particular Infections:** Serious infections from mycobacteria, salmonella and Bacillus Calmette-Guerin (BCG) vaccinations have been reported in patients genetically deficient in IL-12/IL-23. Diagnostic tests for these infections should be considered as dictated by clinical circumstances. (5.2)
- **Tuberculosis (TB):** Evaluate patients for TB prior to initiating treatment with STELARA®. Initiate treatment of latent TB before administering STELARA®. (5.3)
- **Malignancies:** STELARA® may increase risk of malignancy. The safety of STELARA® in patients with a history of or a known malignancy has not been evaluated. (5.4)
- **Hypersensitivity Reactions:** Anaphylaxis or other clinically significant hypersensitivity reactions may occur. (5.5)
- **Reversible Posterior Leukoencephalopathy Syndrome (RPLS):** One case was reported. If suspected, treat promptly and discontinue STELARA®. (5.6)
- **Noninfectious Pneumonia:** Cases of interstitial pneumonia, eosinophilic pneumonia and cryptogenic organizing pneumonia have been reported during post-approval use of STELARA®. If diagnosis is confirmed, discontinue STELARA® and institute appropriate treatment. (5.9)

ADVERSE REACTIONS

Most common adverse reactions are:

- Psoriasis (≥3%): nasopharyngitis, upper respiratory tract infection, headache, and fatigue. (6.1)
- Crohn's Disease, induction (≥3%): vomiting. (6.1)
- Crohn's Disease, maintenance (≥3%): nasopharyngitis, injection site erythema, vulvovaginal candidiasis/mycotic infection, bronchitis, pruritus, urinary tract infection, and sinusitis. (6.1)
- Ulcerative colitis, induction (≥3%): nasopharyngitis (6.1)
- Ulcerative colitis, maintenance (≥3%): nasopharyngitis, headache, abdominal pain, influenza, fever, diarrhea, sinusitis, fatigue, and nausea (6.1)

To report SUSPECTED ADVERSE REACTIONS, contact Janssen Biotech, Inc. at 1-800-JANSSEN (1-800-526-7736) or FDA at 1-800-FDA-1088 or www.fda.gov/medwatch.

See 17 for PATIENT COUNSELING INFORMATION and Medication Guide.

Revised: MM/YYYY

FULL PRESCRIBING INFORMATION: CONTENTS*

1 INDICATIONS AND USAGE

- 1.1 Psoriasis (Ps)
- 1.2 Psoriatic Arthritis (PsA)
- 1.3 Crohn's Disease (CD)
- 1.4 Ulcerative Colitis

2 DOSAGE AND ADMINISTRATION

- 2.1 Psoriasis
- 2.2 Psoriatic Arthritis
- 2.3 Crohn's Disease and Ulcerative Colitis
- 2.4 General Considerations for Administration
- 2.5 Instructions for Administration of STELARA®
Prefilled Syringes Equipped with Needle Safety Guard
- 2.6 Preparation and Administration of STELARA®
130 mg/26 mL (5 mg/mL) Vial for Intravenous Infusion (Crohn's Disease and Ulcerative Colitis)

3 DOSAGE FORMS AND STRENGTHS

4 CONTRAINDICATIONS

5 WARNINGS AND PRECAUTIONS

- 5.1 Infections
- 5.2 Theoretical Risk for Vulnerability to Particular Infections
- 5.3 Pre-treatment Evaluation for Tuberculosis
- 5.4 Malignancies
- 5.5 Hypersensitivity Reactions
- 5.6 Reversible Posterior Leukoencephalopathy Syndrome
- 5.7 Immunizations
- 5.8 Concomitant Therapies
- 5.9 Noninfectious Pneumonia

6 ADVERSE REACTIONS

- 6.1 Clinical Trials Experience

- 6.2 Immunogenicity
- 6.3 Postmarketing Experience

7 DRUG INTERACTIONS

- 7.1 Live Vaccines
- 7.2 Concomitant Therapies
- 7.3 CYP450 Substrates
- 7.4 Allergen Immunotherapy

8 USE IN SPECIFIC POPULATIONS

- 8.1 Pregnancy
- 8.2 Lactation
- 8.4 Pediatric Use
- 8.5 Geriatric Use

10 OVERDOSAGE

11 DESCRIPTION

12 CLINICAL PHARMACOLOGY

- 12.1 Mechanism of Action
- 12.2 Pharmacodynamics
- 12.3 Pharmacokinetics

13 NONCLINICAL TOXICOLOGY

- 13.1 Carcinogenesis, Mutagenesis, Impairment of Fertility
- 13.2 Animal Toxicology and/or Pharmacology

14 CLINICAL STUDIES

- 14.1 Psoriasis
- 14.2 Adolescent Subjects with Plaque Psoriasis
- 14.3 Psoriatic Arthritis
- 14.4 Crohn's Disease
- 14.5 Ulcerative Colitis

15 REFERENCES

16 HOW SUPPLIED/STORAGE AND HANDLING

17 PATIENT COUNSELING INFORMATION

*Sections or subsections omitted from the full prescribing information are not listed.

FULL PRESCRIBING INFORMATION

1 INDICATIONS AND USAGE

1.1 Psoriasis (Ps)

STELARA[®] is indicated for the treatment of patients 12 years or older with moderate to severe plaque psoriasis who are candidates for phototherapy or systemic therapy.

1.2 Psoriatic Arthritis (PsA)

STELARA[®] is indicated for the treatment of adult patients with active psoriatic arthritis. STELARA[®] can be used alone or in combination with methotrexate (MTX).

1.3 Crohn's Disease (CD)

STELARA[®] is indicated for the treatment of adult patients with moderately to severely active Crohn's disease.

1.4 Ulcerative Colitis

STELARA[®] is indicated for the treatment of adult patients with moderately to severely active ulcerative colitis.

2 DOSAGE AND ADMINISTRATION

2.1 Psoriasis

Subcutaneous Adult Dosage Regimen

- For patients weighing 100 kg or less, the recommended dose is 45 mg initially and 4 weeks later, followed by 45 mg every 12 weeks.
- For patients weighing more than 100 kg, the recommended dose is 90 mg initially and 4 weeks later, followed by 90 mg every 12 weeks.

In subjects weighing more than 100 kg, 45 mg was also shown to be efficacious. However, 90 mg resulted in greater efficacy in these subjects [*see Clinical Studies (14)*].

Subcutaneous Adolescent Dosage Regimen

Administer STELARA[®] subcutaneously at Weeks 0 and 4, then every 12 weeks thereafter.

The recommended dose of STELARA[®] for adolescents (12-17 years old) based on body weight is shown below (Table 1).

Table 1: Recommended Dose of STELARA® for Subcutaneous Injection in Adolescent Patients with Psoriasis

Body Weight of Patient at the Time of Dosing	Recommended Dose
less than 60 kg	0.75 mg/kg
60 kg to 100 kg	45 mg
more than 100 kg	90 mg

For adolescent patients weighing less than 60 kg, the administration volume for the recommended dose (0.75 mg/kg) is shown in Table 2; withdraw the appropriate volume from the single-dose vial.

Table 2: Injection volumes of STELARA® 45 mg/0.5 mL single-dose vials for adolescent psoriasis patients less than 60 kg

Body Weight (kg) at the time of dosing	Dose (mg)	Volume of injection (mL)
30	22.5	0.25
31	23.3	0.26
32	24	0.27
33	24.8	0.27
34	25.5	0.28
35	26.3	0.29
36	27	0.3
37	27.8	0.31
38	28.5	0.32
39	29.3	0.32
40	30	0.33
41	30.8	0.34
42	31.5	0.35
43	32.3	0.36
44	33	0.37
45	33.8	0.37
46	34.5	0.38
47	35.3	0.39
48	36	0.4
49	36.8	0.41
50	37.5	0.42
51	38.3	0.42
52	39	0.43
53	39.8	0.44
54	40.5	0.45
55	41.3	0.46
56	42	0.46
57	42.8	0.47
58	43.5	0.48
59	44.3	0.49

2.2 Psoriatic Arthritis

Subcutaneous Adult Dosage Regimen

- The recommended dose is 45 mg initially and 4 weeks later, followed by 45 mg every 12 weeks.
- For patients with co-existent moderate-to-severe plaque psoriasis weighing more than 100 kg, the recommended dose is 90 mg initially and 4 weeks later, followed by 90 mg every 12 weeks.

2.3 Crohn's Disease and Ulcerative Colitis

Intravenous Induction Adult Dosage Regimen

A single intravenous infusion dose of STELARA[®] using the weight-based dosage regimen specified in Table 3 [see *Instructions for dilution of STELARA[®] 130 mg vial for intravenous infusion (2.6)*].

Table 3: Initial Intravenous Dosage of STELARA[®]

Body Weight of Patient at the time of dosing	Dose	Number of 130 mg/26 mL (5 mg/mL) STELARA [®] vials
55 kg or less	260 mg	2
more than 55 kg to 85 kg	390 mg	3
more than 85 kg	520 mg	4

Subcutaneous Maintenance Adult Dosage Regimen

The recommended maintenance dosage is a subcutaneous 90 mg dose administered 8 weeks after the initial intravenous dose, then every 8 weeks thereafter.

2.4 General Considerations for Administration

- STELARA[®] is intended for use under the guidance and supervision of a physician. STELARA[®] should only be administered to patients who will be closely monitored and have regular follow-up visits with a physician. The appropriate dose should be determined by a healthcare provider using the patient's current weight at the time of dosing. In adolescent patients, it is recommended that STELARA[®] be administered by a healthcare provider. If a physician determines that it is appropriate, a patient may self-inject or a caregiver may inject STELARA[®] after proper training in subcutaneous injection technique. Patients should be instructed to follow the directions provided in the Medication Guide [see *Medication Guide*].
- The needle cover on the prefilled syringe contains dry natural rubber (a derivative of latex). The needle cover should not be handled by persons sensitive to latex.
- It is recommended that each injection be administered at a different anatomic location (such as upper arms, gluteal regions, thighs, or any quadrant of abdomen) than the previous injection, and not into areas where the skin is tender, bruised, erythematous, or

indurated. When using the single-dose vial, a 1 mL syringe with a 27 gauge, ½ inch needle is recommended.

- Prior to administration, visually inspect STELARA[®] for particulate matter and discoloration. STELARA[®] is a colorless to light yellow solution and may contain a few small translucent or white particles. Do not use STELARA[®] if it is discolored or cloudy, or if other particulate matter is present. STELARA[®] does not contain preservatives; therefore, discard any unused product remaining in the vial and/or syringe.

2.5 Instructions for Administration of STELARA[®] Prefilled Syringes Equipped with Needle Safety Guard

Refer to the diagram below for the provided instructions.

To prevent premature activation of the needle safety guard, do not touch the NEEDLE GUARD ACTIVATION CLIPS at any time during use.

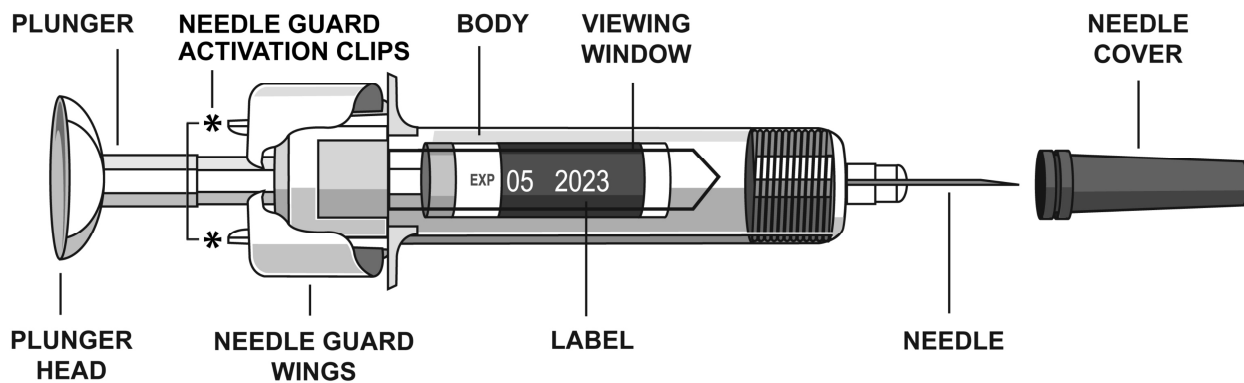

- Hold the BODY and remove the NEEDLE COVER. **Do not hold the PLUNGER or PLUNGER HEAD while removing the NEEDLE COVER or the PLUNGER may move. Do not use the prefilled syringe if it is dropped without the NEEDLE COVER in place.**
- Inject STELARA[®] subcutaneously as recommended [see *Dosage and Administration (2.1, 2.2, 2.3)*].

- Inject all of the medication by pushing in the PLUNGER until the PLUNGER HEAD is completely between the needle guard wings. **Injection of the entire prefilled syringe contents is necessary to activate the needle guard.**



- After injection, maintain the pressure on the PLUNGER HEAD and remove the needle from the skin. Slowly take your thumb off the PLUNGER HEAD to allow the empty syringe to move up until the entire needle is covered by the needle guard, as shown by the illustration below:

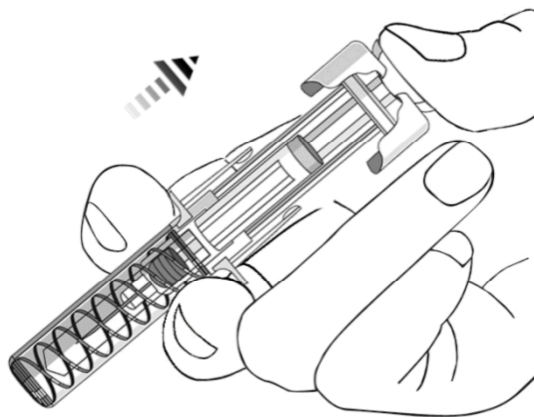

- Used syringes should be placed in a puncture-resistant container.

2.6 Preparation and Administration of STELARA[®] 130 mg/26 mL (5 mg/mL) Vial for Intravenous Infusion (Crohn's Disease and Ulcerative Colitis)

STELARA[®] solution for intravenous infusion must be diluted, prepared and infused by a healthcare professional using aseptic technique.

1. Calculate the dose and the number of STELARA[®] vials needed based on patient weight (Table 3). Each 26 mL vial of STELARA[®] contains 130 mg of ustekinumab.
2. Withdraw, and then discard a volume of the 0.9% Sodium Chloride Injection, USP from the 250 mL infusion bag equal to the volume of STELARA[®] to be added (discard 26 mL sodium chloride for each vial of STELARA[®] needed, for 2 vials- discard 52 mL, for

3 vials- discard 78 mL, 4 vials- discard 104 mL). Alternatively, a 250 mL infusion bag containing 0.45% Sodium Chloride Injection, USP may be used.

3. Withdraw 26 mL of STELARA[®] from each vial needed and add it to the 250 mL infusion bag. The final volume in the infusion bag should be 250 mL. Gently mix.
4. Visually inspect the diluted solution before infusion. Do not use if visibly opaque particles, discoloration or foreign particles are observed.
5. Infuse the diluted solution over a period of at least one hour. Once diluted, the infusion should be completely administered within eight hours of the dilution in the infusion bag.
6. Use only an infusion set with an in-line, sterile, non-pyrogenic, low protein-binding filter (pore size 0.2 micrometer).
7. Do not infuse STELARA[®] concomitantly in the same intravenous line with other agents.
8. STELARA[®] does not contain preservatives. Each vial is for single use only. Discard any remaining solution. Dispose any unused medicinal product in accordance with local requirements.

Storage

If necessary, the diluted infusion solution may be kept at room temperature up to 25°C (77°F) for up to 7 hours. Storage time at room temperature begins once the diluted solution has been prepared. The infusion should be completed within 8 hours after the dilution in the infusion bag (cumulative time after preparation including the storage and the infusion period). Do not freeze. Discard any unused portion of the infusion solution.

3 DOSAGE FORMS AND STRENGTHS

STELARA[®] (ustekinumab) is a colorless to light yellow solution and may contain a few small translucent or white particles.

Subcutaneous Injection

- Injection: 45 mg/0.5 mL or 90 mg/mL solution in a single-dose prefilled syringe
- Injection: 45 mg/0.5 mL solution in a single-dose vial

Intravenous Infusion

- Injection: 130 mg/26 mL (5 mg/mL) solution in a single-dose vial

4 CONTRAINDICATIONS

STELARA[®] is contraindicated in patients with clinically significant hypersensitivity to ustekinumab or to any of the excipients [see *Warnings and Precautions (5.5)*].

5 WARNINGS AND PRECAUTIONS

5.1 Infections

STELARA[®] may increase the risk of infections and reactivation of latent infections. Serious bacterial, mycobacterial, fungal, and viral infections were observed in patients receiving STELARA[®] [see *Adverse Reactions (6.1, 6.3)*].

Serious infections requiring hospitalization, or otherwise clinically significant infections, reported in clinical studies included the following:

- *Psoriasis*: diverticulitis, cellulitis, pneumonia, appendicitis, cholecystitis, sepsis, osteomyelitis, viral infections, gastroenteritis and urinary tract infections.
- *Psoriatic arthritis*: cholecystitis.
- *Crohn's disease*: anal abscess, gastroenteritis, ophthalmic herpes zoster, pneumonia, and listeria meningitis.
- *Ulcerative colitis*: gastroenteritis, ophthalmic herpes zoster, pneumonia, and listeriosis.

Treatment with STELARA[®] should not be initiated in patients with any clinically important active infection until the infection resolves or is adequately treated. Consider the risks and benefits of treatment prior to initiating use of STELARA[®] in patients with a chronic infection or a history of recurrent infection.

Instruct patients to seek medical advice if signs or symptoms suggestive of an infection occur while on treatment with STELARA[®] and consider discontinuing STELARA[®] for serious or clinically significant infections until the infection resolves or is adequately treated.

5.2 Theoretical Risk for Vulnerability to Particular Infections

Individuals genetically deficient in IL-12/IL-23 are particularly vulnerable to disseminated infections from mycobacteria (including nontuberculous, environmental mycobacteria), salmonella (including nontyphi strains), and Bacillus Calmette-Guerin (BCG) vaccinations. Serious infections and fatal outcomes have been reported in such patients.

It is not known whether patients with pharmacologic blockade of IL-12/IL-23 from treatment with STELARA[®] may be susceptible to these types of infections. Appropriate diagnostic testing should be considered, e.g., tissue culture, stool culture, as dictated by clinical circumstances.

5.3 Pre-treatment Evaluation for Tuberculosis

Evaluate patients for tuberculosis infection prior to initiating treatment with STELARA[®].

Do not administer STELARA[®] to patients with active tuberculosis infection. Initiate treatment of latent tuberculosis prior to administering STELARA[®]. Consider anti-tuberculosis therapy prior to initiation of STELARA[®] in patients with a past history of latent or active tuberculosis in whom an adequate course of treatment cannot be confirmed. Closely monitor patients receiving STELARA[®] for signs and symptoms of active tuberculosis during and after treatment.

5.4 Malignancies

STELARA[®] is an immunosuppressant and may increase the risk of malignancy. Malignancies were reported among subjects who received STELARA[®] in clinical studies [see *Adverse Reactions (6.1)*]. In rodent models, inhibition of IL-12/IL-23p40 increased the risk of malignancy [see *Nonclinical Toxicology (13)*].

The safety of STELARA[®] has not been evaluated in patients who have a history of malignancy or who have a known malignancy.

There have been post-marketing reports of the rapid appearance of multiple cutaneous squamous cell carcinomas in patients receiving STELARA[®] who had pre-existing risk factors for developing non-melanoma skin cancer. All patients receiving STELARA[®] should be monitored for the appearance of non-melanoma skin cancer. Patients greater than 60 years of age, those with a medical history of prolonged immunosuppressant therapy and those with a history of PUVA treatment should be followed closely [see *Adverse Reactions (6.1)*].

5.5 Hypersensitivity Reactions

Hypersensitivity reactions, including anaphylaxis and angioedema, have been reported with STELARA[®] [see *Adverse Reactions (6.1, 6.3)*]. If an anaphylactic or other clinically significant hypersensitivity reaction occurs, institute appropriate therapy and discontinue STELARA[®].

5.6 Reversible Posterior Leukoencephalopathy Syndrome

One case of reversible posterior leukoencephalopathy syndrome (RPLS) was observed in clinical studies of psoriasis and psoriatic arthritis. The subject, who had received 12 doses of STELARA[®] over approximately two years, presented with headache, seizures and confusion. No additional STELARA[®] injections were administered and the subject fully recovered with appropriate treatment. No cases of RPLS were observed in clinical studies of Crohn's disease or ulcerative colitis.

RPLS is a neurological disorder, which is not caused by demyelination or a known infectious agent. RPLS can present with headache, seizures, confusion and visual disturbances. Conditions with which it has been associated include preeclampsia, eclampsia, acute hypertension, cytotoxic agents and immunosuppressive therapy. Fatal outcomes have been reported.

If RPLS is suspected, administer appropriate treatment and discontinue STELARA[®].

5.7 Immunizations

Prior to initiating therapy with STELARA[®], patients should receive all age-appropriate immunizations as recommended by current immunization guidelines. Patients being treated with STELARA[®] should not receive live vaccines. BCG vaccines should not be given during treatment with STELARA[®] or for one year prior to initiating treatment or one year following discontinuation of treatment. Caution is advised when administering live vaccines to household contacts of patients receiving STELARA[®] because of the potential risk for shedding from the household contact and transmission to patient.

Non-live vaccinations received during a course of STELARA[®] may not elicit an immune response sufficient to prevent disease.

5.8 Concomitant Therapies

In clinical studies of psoriasis the safety of STELARA[®] in combination with other immunosuppressive agents or phototherapy was not evaluated. Ultraviolet-induced skin cancers developed earlier and more frequently in mice genetically manipulated to be deficient in both IL-12 and IL-23 or IL-12 alone [see *Nonclinical Toxicology (13.1)*].

5.9 Noninfectious Pneumonia

Cases of interstitial pneumonia, eosinophilic pneumonia and cryptogenic organizing pneumonia have been reported during post-approval use of STELARA[®]. Clinical presentations included cough, dyspnea, and interstitial infiltrates following one to three doses. Serious outcomes have included respiratory failure and prolonged hospitalization. Patients improved with discontinuation of therapy and in certain cases administration of corticosteroids. If diagnosis is confirmed, discontinue STELARA[®] and institute appropriate treatment [see *Postmarketing Experience (6.3)*].

6 ADVERSE REACTIONS

The following serious adverse reactions are discussed elsewhere in the label:

- Infections [see *Warnings and Precautions (5.1)*]
- Malignancies [see *Warnings and Precautions (5.4)*]
- Hypersensitivity Reactions [see *Warnings and Precautions (5.5)*]
- Reversible Posterior Leukoencephalopathy Syndrome [see *Warnings and Precautions (5.6)*]

6.1 Clinical Trials Experience

Because clinical trials are conducted under widely varying conditions, adverse reaction rates observed in the clinical trials of a drug cannot be directly compared to rates in the clinical trials of another drug and may not reflect the rates observed in practice.

Adult Subjects with Plaque Psoriasis

The safety data reflect exposure to STELARA[®] in 3117 adult psoriasis subjects, including 2414 exposed for at least 6 months, 1855 exposed for at least one year, 1653 exposed for at least two years, 1569 exposed for at least three years, 1482 exposed for at least four years and 838 exposed for at least five years.

Table 4 summarizes the adverse reactions that occurred at a rate of at least 1% and at a higher rate in the STELARA[®] groups than the placebo group during the placebo-controlled period of Ps STUDY 1 and Ps STUDY 2 [see *Clinical Studies (14)*].

Table 4: Adverse Reactions Reported by ≥1% of Subjects through Week 12 in Ps STUDY 1 and Ps STUDY 2

	STELARA [®]		
	Placebo	45 mg	90 mg
Subjects treated	665	664	666
Nasopharyngitis	51 (8%)	56 (8%)	49 (7%)
Upper respiratory tract infection	30 (5%)	36 (5%)	28 (4%)
Headache	23 (3%)	33 (5%)	32 (5%)
Fatigue	14 (2%)	18 (3%)	17 (3%)
Diarrhea	12 (2%)	13 (2%)	13 (2%)
Back pain	8 (1%)	9 (1%)	14 (2%)
Dizziness	8 (1%)	8 (1%)	14 (2%)
Pharyngolaryngeal pain	7 (1%)	9 (1%)	12 (2%)
Pruritus	9 (1%)	10 (2%)	9 (1%)
Injection site erythema	3 (<1%)	6 (1%)	13 (2%)
Myalgia	4 (1%)	7 (1%)	8 (1%)
Depression	3 (<1%)	8 (1%)	4 (1%)

Adverse reactions that occurred at rates less than 1% in the controlled period of Ps STUDIES 1 and 2 through week 12 included: cellulitis, herpes zoster, diverticulitis and certain injection site reactions (pain, swelling, pruritus, induration, hemorrhage, bruising, and irritation).

One case of RPLS occurred during clinical studies [see *Warnings and Precautions (5.6)*].

Infections

In the placebo-controlled period of clinical studies of psoriasis subjects (average follow-up of 12.6 weeks for placebo-treated subjects and 13.4 weeks for STELARA[®]-treated subjects), 27% of STELARA[®]-treated subjects reported infections (1.39 per subject-year of follow-up) compared with 24% of placebo-treated subjects (1.21 per subject-year of follow-up). Serious infections occurred in 0.3% of STELARA[®]-treated subjects (0.01 per subject-year of follow-up) and in 0.4% of placebo-treated subjects (0.02 per subject-year of follow-up) [see *Warnings and Precautions (5.1)*].

In the controlled and non-controlled portions of psoriasis clinical studies (median follow-up of 3.2 years), representing 8998 subject-years of exposure, 72.3% of STELARA[®]-treated subjects reported infections (0.87 per subject-years of follow-up). Serious infections were reported in 2.8% of subjects (0.01 per subject-years of follow-up).

Malignancies

In the controlled and non-controlled portions of psoriasis clinical studies (median follow-up of 3.2 years, representing 8998 subject-years of exposure), 1.7% of STELARA[®]-treated subjects reported malignancies excluding non-melanoma skin cancers (0.60 per hundred subject-years of follow-up). Non-melanoma skin cancer was reported in 1.5% of STELARA[®]-treated subjects (0.52 per hundred subject-years of follow-up) [see *Warnings and Precautions (5.4)*]. The most frequently observed malignancies other than non-melanoma skin cancer during the clinical studies were: prostate, melanoma, colorectal and breast. Malignancies other than non-melanoma skin cancer in STELARA[®]-treated patients during the controlled and uncontrolled portions of

studies were similar in type and number to what would be expected in the general U.S. population according to the SEER database (adjusted for age, gender and race).¹

Adolescent Subjects with Plaque Psoriasis

The safety of STELARA[®] was assessed in a study of 110 subjects 12 to 17 years of age with moderate to severe plaque psoriasis. The safety profile in these subjects through Week 60 was similar to the safety profile from studies in adults with plaque psoriasis.

Psoriatic Arthritis

The safety of STELARA[®] was assessed in 927 patients in two randomized, double-blind, placebo-controlled studies in adult patients with active psoriatic arthritis (PsA). The overall safety profile of STELARA[®] in patients with PsA was consistent with the safety profile seen in adult psoriasis clinical studies. A higher incidence of arthralgia, nausea, and dental infections was observed in STELARA[®]-treated patients when compared with placebo-treated patients (3% vs. 1% for arthralgia and 3% vs. 1% for nausea; 1% vs. 0.6% for dental infections) in the placebo-controlled portions of the PsA clinical studies.

Crohn's Disease

The safety of STELARA[®] was assessed in 1407 patients with moderately to severely active Crohn's disease (Crohn's Disease Activity Index [CDAI] greater than or equal to 220 and less than or equal to 450) in three randomized, double-blind, placebo-controlled, parallel-group, multicenter studies. These 1407 patients included 40 patients who received a prior investigational intravenous ustekinumab formulation but were not included in the efficacy analyses. In Studies CD-1 and CD-2 there were 470 patients who received STELARA[®] 6 mg/kg as a weight-based single intravenous induction dose and 466 who received placebo [*see Dosage and Administration (2.3)*]. Patients who were responders in either Study CD-1 or CD-2 were randomized to receive a subcutaneous maintenance regimen of either 90 mg STELARA[®] every 8 weeks, or placebo for 44 weeks in Study CD-3. Patients in these 3 studies may have received other concomitant therapies including aminosalicylates, immunomodulatory agents [azathioprine (AZA), 6-mercaptopurine (6-MP), MTX], oral corticosteroids (prednisone or budesonide), and/or antibiotics for their Crohn's disease [*see Clinical Studies (14.4)*].

The overall safety profile of STELARA[®] was consistent with the safety profile seen in the adult psoriasis and psoriatic arthritis clinical studies. Common adverse reactions in Studies CD-1 and CD-2 and in Study CD-3 are listed in Tables 5 and 6, respectively.

Table 5: Common adverse reactions through Week 8 in Studies CD-1 and CD-2 occurring in ≥3% of STELARA[®]-treated patients and higher than placebo

	Placebo N=466	STELARA [®] 6 mg/kg single intravenous induction dose N=470
Vomiting	3%	4%

Other less common adverse reactions reported in patients in Studies CD-1 and CD-2 included asthenia (1% vs 0.4%), acne (1% vs 0.4%), and pruritus (2% vs 0.4%).

Table 6: Common adverse reactions through Week 44 in Study CD-3 occurring in $\geq 3\%$ of STELARA[®]-treated patients and higher than placebo

	Placebo N=133	STELARA [®] 90 mg subcutaneous maintenance dose every 8 weeks N=131
Nasopharyngitis	8%	11%
Injection site erythema	0	5%
Vulvovaginal candidiasis/mycotic infection	1%	5%
Bronchitis	3%	5%
Pruritus	2%	4%
Urinary tract infection	2%	4%
Sinusitis	2%	3%

Infections

In patients with Crohn's disease, serious or other clinically significant infections included anal abscess, gastroenteritis, and pneumonia. In addition, listeria meningitis and ophthalmic herpes zoster were reported in one patient each [see *Warnings and Precautions (5.1)*].

Malignancies

With up to one year of treatment in the Crohn's disease clinical studies, 0.2% of STELARA[®]-treated patients (0.36 events per hundred patient-years) and 0.2% of placebo-treated patients (0.58 events per hundred patient-years) developed non-melanoma skin cancer. Malignancies other than non-melanoma skin cancers occurred in 0.2% of STELARA[®]-treated patients (0.27 events per hundred patient-years) and in none of the placebo-treated patients.

Hypersensitivity Reactions Including Anaphylaxis

In CD studies, two patients reported hypersensitivity reactions following STELARA[®] administration. One patient experienced signs and symptoms consistent with anaphylaxis (tightness of the throat, shortness of breath, and flushing) after a single subcutaneous administration (0.1% of patients receiving subcutaneous STELARA[®]). In addition, one patient experienced signs and symptoms consistent with or related to a hypersensitivity reaction (chest discomfort, flushing, urticaria, and increased body temperature) after the initial intravenous STELARA[®] dose (0.08% of patients receiving intravenous STELARA[®]). These patients were treated with oral antihistamines or corticosteroids and in both cases symptoms resolved within an hour.

Ulcerative Colitis

The safety of STELARA[®] was evaluated in two randomized, double-blind, placebo-controlled clinical studies (UC-1 [IV induction] and UC-2 [SC maintenance]) in 960 adult patients with moderately to severely active ulcerative colitis [see *Clinical Studies (14.5)*]. The overall safety profile of STELARA[®] in patients with ulcerative colitis was consistent with the safety profile seen across all approved indications. Adverse reactions reported in at least 3% of STELARA[®]-treated patients and at a higher rate than placebo were:

- Induction (UC-1): nasopharyngitis (7% vs 4%).
- Maintenance (UC-2): nasopharyngitis (24% vs 20%), headache (10% vs 4%), abdominal pain (7% vs 3%), influenza (6% vs 5%), fever (5% vs. 4%), diarrhea (4% vs 1%), sinusitis (4% vs 1%), fatigue (4% vs 2%), and nausea (3% vs 2%).

Infections

In patients with ulcerative colitis, serious or other clinically significant infections included gastroenteritis and pneumonia. In addition, listeriosis and ophthalmic herpes zoster were reported in one patient each [see *Warnings and Precautions (5.1)*].

Malignancies

With up to one year of treatment in the ulcerative colitis clinical studies, 0.4% of STELARA[®]-treated patients (0.48 events per hundred patient-years) and 0.0% of placebo-treated patients (0.00 events per hundred patient-years) developed non-melanoma skin cancer. Malignancies other than non-melanoma skin cancers occurred in 0.5% of STELARA[®]-treated patients (0.64 events per hundred patient-years) and 0.2% of placebo-treated patients (0.40 events per hundred patient-years).

6.2 Immunogenicity

As with all therapeutic proteins, there is potential for immunogenicity. The detection of antibody formation is highly dependent on the sensitivity and specificity of the assay. Additionally, the observed incidence of antibody (including neutralizing antibody) positivity in an assay may be influenced by several factors, including assay methodology, sample handling, timing of sample collection, concomitant medications and underlying disease. For these reasons, comparison of the incidence of antibodies to ustekinumab in the studies described below with the incidence of antibodies to other products may be misleading.

Approximately 6 to 12.4% of subjects treated with STELARA[®] in psoriasis and psoriatic arthritis clinical studies developed antibodies to ustekinumab, which were generally low-titer. In psoriasis clinical studies, antibodies to ustekinumab were associated with reduced or undetectable serum ustekinumab concentrations and reduced efficacy. In psoriasis studies, the majority of patients who were positive for antibodies to ustekinumab had neutralizing antibodies.

In Crohn's disease and ulcerative colitis clinical studies, 2.9% and 4.6% of patients, respectively, developed antibodies to ustekinumab when treated with STELARA[®] for approximately one year. No apparent association between the development of antibodies to ustekinumab and the development of injection site reactions was seen.

6.3 Postmarketing Experience

The following adverse reactions have been reported during post-approval of STELARA[®]. Because these reactions are reported voluntarily from a population of uncertain size, it is not always possible to reliably estimate their frequency or establish a causal relationship to STELARA[®] exposure.

Immune system disorders: Serious hypersensitivity reactions (including anaphylaxis and angioedema), other hypersensitivity reactions (including rash and urticaria) [see *Warnings and Precautions (5.5)*].

Infections and infestations: Lower respiratory tract infection (including opportunistic fungal infections and tuberculosis) [see *Warnings and Precautions (5.1)*].

Respiratory, thoracic and mediastinal disorders: Interstitial pneumonia, eosinophilic pneumonia and cryptogenic organizing pneumonia [see *Warnings and Precautions (5.9)*].

Skin reactions: Pustular psoriasis, erythrodermic psoriasis.

7 DRUG INTERACTIONS

7.1 Live Vaccines

Avoid use of live vaccines with STELARA[®] [see *Warnings and Precautions (5.7)*].

7.2 Concomitant Therapies

In psoriasis studies the safety of STELARA[®] in combination with immunosuppressive agents or phototherapy has not been evaluated [see *Warnings and Precautions (5.8)*]. In psoriatic arthritis studies, concomitant MTX use did not appear to influence the safety or efficacy of STELARA[®]. In Crohn's disease and ulcerative colitis induction studies, immunomodulators (6-MP, AZA, MTX) were used concomitantly in approximately 30% of patients and corticosteroids were used concomitantly in approximately 40% and 50% of Crohn's disease and ulcerative colitis patients, respectively. Use of these concomitant therapies did not appear to influence the overall safety or efficacy of STELARA[®].

7.3 CYP450 Substrates

The formation of CYP450 enzymes can be altered by increased levels of certain cytokines (e.g., IL-1, IL-6, IL-10, TNF α , IFN) during chronic inflammation. Thus, STELARA[®], an antagonist of IL-12 and IL-23, could normalize the formation of CYP450 enzymes. Upon initiation of STELARA[®] in patients who are receiving concomitant CYP450 substrates, particularly those with a narrow therapeutic index, monitoring for therapeutic effect (e.g., for warfarin) or drug concentration (e.g., for cyclosporine) should be considered and the individual dose of the drug adjusted as needed [see *Clinical Pharmacology (12.3)*].

7.4 Allergen Immunotherapy

STELARA[®] has not been evaluated in patients who have undergone allergy immunotherapy. STELARA[®] may decrease the protective effect of allergen immunotherapy (decrease tolerance) which may increase the risk of an allergic reaction to a dose of allergen immunotherapy. Therefore, caution should be exercised in patients receiving or who have received allergen immunotherapy, particularly for anaphylaxis.

8 USE IN SPECIFIC POPULATIONS

8.1 Pregnancy

Risk Summary

Limited data on the use of STELARA[®] in pregnant women are insufficient to inform a drug associated risk [see Data]. In animal reproductive and developmental toxicity studies, no adverse developmental effects were observed after administration of ustekinumab to pregnant monkeys at exposures greater than 100 times the human exposure at the maximum recommended human subcutaneous dose (MRHD).

All pregnancies have a background risk of birth defect, loss, or other adverse outcomes. The estimated background risk of major birth defects and miscarriage for the indicated population(s) are unknown. In the U.S. general population, the estimated background risk of major birth defects and miscarriage of clinically recognized pregnancies is 2% to 4% and 15% to 20%, respectively.

Data

Human Data

Limited data on use of STELARA[®] in pregnant women from observational studies, published case reports, and postmarketing surveillance are insufficient to inform a drug associated risk.

Animal Data

Ustekinumab was tested in two embryo-fetal development toxicity studies in cynomolgus monkeys. No teratogenic or other adverse developmental effects were observed in fetuses from pregnant monkeys that were administered ustekinumab subcutaneously twice weekly or intravenously weekly during the period of organogenesis. Serum concentrations of ustekinumab in pregnant monkeys were greater than 100 times the serum concentration in patients treated subcutaneously with 90 mg of ustekinumab weekly for 4 weeks.

In a combined embryo-fetal development and pre- and post-natal development toxicity study, pregnant cynomolgus monkeys were administered subcutaneous doses of ustekinumab twice weekly at exposures greater than 100 times the human subcutaneous exposure from the beginning of organogenesis to Day 33 after delivery. Neonatal deaths occurred in the offspring of one monkey administered ustekinumab at 22.5 mg/kg and one monkey dosed at 45 mg/kg. No ustekinumab-related effects on functional, morphological, or immunological development were observed in the neonates from birth through six months of age.

8.2 Lactation

Risk Summary

There are no data on the presence of ustekinumab in human milk, the effects on the breastfed infant, or the effects on milk production. Ustekinumab was present in the milk of lactating monkeys administered ustekinumab. Due to species-specific differences in lactation physiology, animal data may not reliably predict drug levels in human milk. Maternal IgG is known to be

present in human milk. Published data suggest that the systemic exposure to a breastfed infant is expected to be low because ustekinumab is a large molecule and is degraded in the gastrointestinal tract. However, if ustekinumab is transferred into human milk the effects of local exposure in the gastrointestinal tract are unknown.

The developmental and health benefits of breastfeeding should be considered along with the mother's clinical need for STELARA[®] and any potential adverse effects on the breastfed child from STELARA[®] or from the underlying maternal condition.

8.4 Pediatric Use

The safety and effectiveness of STELARA[®] have been established in pediatric patients 12 to 17 years old with moderate to severe plaque psoriasis. Use of STELARA[®] in this age group is supported by evidence from a multicenter, randomized, 60-week trial that included a 12-week, double-blind, placebo-controlled, parallel-group portion, in 110 pediatric subjects 12 years and older [see *Adverse Reactions (6.1)*, *Clinical Studies (14.2)*]. The safety and effectiveness of STELARA[®] for pediatric patients less than 12 years of age with psoriasis have not been established.

The safety and effectiveness of STELARA[®] have not been established in pediatric patients with psoriatic arthritis, Crohn's disease or ulcerative colitis.

8.5 Geriatric Use

Of the 6709 patients exposed to STELARA[®], a total of 340 were 65 years or older (183 patients with psoriasis, 65 patients with psoriatic arthritis, 58 patients with Crohn's disease and 34 patients with ulcerative colitis), and 40 patients were 75 years or older. Although no overall differences in safety or efficacy were observed between older and younger patients, the number of patients aged 65 and over is not sufficient to determine whether they respond differently from younger patients.

10 OVERDOSAGE

Single doses up to 6 mg/kg intravenously have been administered in clinical studies without dose-limiting toxicity. In case of overdosage, it is recommended that the patient be monitored for any signs or symptoms of adverse reactions or effects and appropriate symptomatic treatment be instituted immediately.

11 DESCRIPTION

Ustekinumab, a human IgG1κ monoclonal antibody, is a human interleukin-12 and -23 antagonist. Using DNA recombinant technology, ustekinumab is produced in a murine cell line (Sp2/0). The manufacturing process contains steps for the clearance of viruses. Ustekinumab is comprised of 1326 amino acids and has an estimated molecular mass that ranges from 148,079 to 149,690 Daltons.

STELARA[®] (ustekinumab) injection is a sterile, preservative-free, colorless to light yellow solution and may contain a few small translucent or white particles with pH of 5.7- 6.3.

STELARA® for Subcutaneous Use

Available as 45 mg of ustekinumab in 0.5 mL and 90 mg of ustekinumab in 1 mL, supplied as a sterile solution in a single-dose prefilled syringe with a 27 gauge fixed ½ inch needle and as 45 mg of ustekinumab in 0.5 mL in a single-dose 2 mL Type I glass vial with a coated stopper. The syringe is fitted with a passive needle guard and a needle cover that contains dry natural rubber (a derivative of latex).

Each 0.5 mL prefilled syringe or vial delivers 45 mg ustekinumab, L-histidine and L-histidine monohydrochloride monohydrate (0.5 mg), Polysorbate 80 (0.02 mg), and sucrose (38 mg).

Each 1 mL prefilled syringe delivers 90 mg ustekinumab, L-histidine and L-histidine monohydrochloride monohydrate (1 mg), Polysorbate 80 (0.04 mg), and sucrose (76 mg).

STELARA® for Intravenous Infusion

Available as 130 mg of ustekinumab in 26 mL, supplied as a single-dose 30 mL Type I glass vial with a coated stopper.

Each 26 mL vial delivers 130 mg ustekinumab, EDTA disodium salt dihydrate (0.52 mg), L-histidine (20 mg), L-histidine hydrochloride monohydrate (27 mg), L-methionine (10.4 mg), Polysorbate 80 (10.4 mg) and sucrose (2210 mg).

12 CLINICAL PHARMACOLOGY

12.1 Mechanism of Action

Ustekinumab is a human IgG1κ monoclonal antibody that binds with specificity to the p40 protein subunit used by both the IL-12 and IL-23 cytokines. IL-12 and IL-23 are naturally occurring cytokines that are involved in inflammatory and immune responses, such as natural killer cell activation and CD4+ T-cell differentiation and activation. In *in vitro* models, ustekinumab was shown to disrupt IL-12 and IL-23 mediated signaling and cytokine cascades by disrupting the interaction of these cytokines with a shared cell-surface receptor chain, IL-12Rβ1. The cytokines IL-12 and IL-23 have been implicated as important contributors to the chronic inflammation that is a hallmark of Crohn's disease and ulcerative colitis. In animal models of colitis, genetic absence or antibody blockade of the p40 subunit of IL-12 and IL-23, the target of ustekinumab, was shown to be protective.

12.2 Pharmacodynamics

Psoriasis

In a small exploratory study, a decrease was observed in the expression of mRNA of its molecular targets IL-12 and IL-23 in lesional skin biopsies measured at baseline and up to two weeks post-treatment in subjects with psoriasis.

Ulcerative Colitis

In both study UC-1 (induction) and study UC-2 (maintenance), a positive relationship was observed between exposure and rates of clinical remission, clinical response, and endoscopic

improvement. The response rate approached a plateau at the ustekinumab exposures associated with the recommended dosing regimen for maintenance treatment [see *Clinical Studies (14.5)*].

12.3 Pharmacokinetics

Absorption

In adult subjects with psoriasis, the median time to reach the maximum serum concentration (T_{max}) was 13.5 days and 7 days, respectively, after a single subcutaneous administration of 45 mg (N=22) and 90 mg (N=24) of ustekinumab. In healthy subjects (N=30), the median T_{max} value (8.5 days) following a single subcutaneous administration of 90 mg of ustekinumab was comparable to that observed in subjects with psoriasis.

Following multiple subcutaneous doses of STELARA[®] in adult subjects with psoriasis, steady-state serum concentrations of ustekinumab were achieved by Week 28. The mean (\pm SD) steady-state trough serum ustekinumab concentrations were 0.69 ± 0.69 mcg/mL for patients less than or equal to 100 kg receiving a 45 mg dose and 0.74 ± 0.78 mcg/mL for patients greater than 100 kg receiving a 90 mg dose. There was no apparent accumulation in serum ustekinumab concentration over time when given subcutaneously every 12 weeks.

Following the recommended intravenous induction dose, mean \pm SD peak serum ustekinumab concentration was 125.2 ± 33.6 mcg/mL in patients with Crohn's disease, and 129.1 ± 27.6 mcg/mL in patients with ulcerative colitis. Starting at Week 8, the recommended subcutaneous maintenance dosing of 90 mg ustekinumab was administered every 8 weeks. Steady state ustekinumab concentration was achieved by the start of the second maintenance dose. There was no apparent accumulation in ustekinumab concentration over time when given subcutaneously every 8 weeks. Mean \pm SD steady-state trough concentration was 2.5 ± 2.1 mcg/mL in patients with Crohn's disease, and 3.3 ± 2.3 mcg/mL in patients with ulcerative colitis for 90 mg ustekinumab administered every 8 weeks.

Distribution

Population pharmacokinetic analyses showed that the volume of distribution of ustekinumab in the central compartment was 2.7 L (95% CI: 2.69, 2.78) in patients with Crohn's disease and 3.0 L (95% CI: 2.96, 3.07) in patients with ulcerative colitis. The total volume of distribution at steady-state was 4.6 L in patients with Crohn's disease and 4.4 L in patients with ulcerative colitis.

Elimination

The mean (\pm SD) half-life ranged from 14.9 ± 4.6 to 45.6 ± 80.2 days across all psoriasis studies following subcutaneous administration. Population pharmacokinetic analyses showed that the clearance of ustekinumab was 0.19 L/day (95% CI: 0.185, 0.197) in patients with Crohn's disease and 0.19 L/day (95% CI: 0.179, 0.192) in patients with ulcerative colitis with an estimated median terminal half-life of approximately 19 days for both IBD (Crohn's disease and ulcerative colitis) populations.

These results indicate the pharmacokinetics of ustekinumab were similar between patients with Crohn's disease and ulcerative colitis.

Metabolism

The metabolic pathway of ustekinumab has not been characterized. As a human IgG1κ monoclonal antibody, ustekinumab is expected to be degraded into small peptides and amino acids via catabolic pathways in the same manner as endogenous IgG.

Specific Populations

Weight

When given the same dose, subjects with psoriasis or psoriatic arthritis weighing more than 100 kg had lower median serum ustekinumab concentrations compared with those subjects weighing 100 kg or less. The median trough serum concentrations of ustekinumab in subjects of higher weight (greater than 100 kg) in the 90 mg group were comparable to those in subjects of lower weight (100 kg or less) in the 45 mg group.

Age: Geriatric Population

A population pharmacokinetic analysis (N=106/1937 patients with psoriasis greater than or equal to 65 years old) was performed to evaluate the effect of age on the pharmacokinetics of ustekinumab. There were no apparent changes in pharmacokinetic parameters (clearance and volume of distribution) in subjects older than 65 years old.

Age: Pediatric Population

Following multiple recommended doses of STELARA[®] in adolescent subjects 12 to 17 years of age with psoriasis, steady-state serum concentrations of ustekinumab were achieved by Week 28. At Week 28, the mean ±SD steady-state trough serum ustekinumab concentration was 0.54 ± 0.43 mcg/mL.

Drug Interaction Studies

The effects of IL-12 or IL-23 on the regulation of CYP450 enzymes were evaluated in an *in vitro* study using human hepatocytes, which showed that IL-12 and/or IL-23 at levels of 10 ng/mL did not alter human CYP450 enzyme activities (CYP1A2, 2B6, 2C9, 2C19, 2D6, or 3A4). However, the clinical relevance of *in vitro* data has not been established [see *Drug Interactions (7.3)*].

No *in vivo* drug interaction studies have been conducted with STELARA[®].

Population pharmacokinetic analyses indicated that the clearance of ustekinumab was not impacted by concomitant MTX, NSAIDs, and oral corticosteroids, or prior exposure to a TNF blocker in patients with psoriatic arthritis.

In patients with Crohn's disease and ulcerative colitis, population pharmacokinetic analyses did not indicate changes in ustekinumab clearance with concomitant use of corticosteroids or immunomodulators (AZA, 6-MP, or MTX); and serum ustekinumab concentrations were not impacted by concomitant use of these medications.

13 NONCLINICAL TOXICOLOGY

13.1 Carcinogenesis, Mutagenesis, Impairment of Fertility

Animal studies have not been conducted to evaluate the carcinogenic or mutagenic potential of STELARA[®]. Published literature showed that administration of murine IL-12 caused an anti-tumor effect in mice that contained transplanted tumors and IL-12/IL-23p40 knockout mice or mice treated with anti-IL-12/IL-23p40 antibody had decreased host defense to tumors. Mice genetically manipulated to be deficient in both IL-12 and IL-23 or IL-12 alone developed UV-induced skin cancers earlier and more frequently compared to wild-type mice. The relevance of these experimental findings in mouse models for malignancy risk in humans is unknown.

No effects on fertility were observed in male cynomolgus monkeys that were administered ustekinumab at subcutaneous doses up to 45 mg/kg twice weekly (45 times the MRHD on a mg/kg basis) prior to and during the mating period. However, fertility and pregnancy outcomes were not evaluated in mated females.

No effects on fertility were observed in female mice that were administered an analogous IL-12/IL-23p40 antibody by subcutaneous administration at doses up to 50 mg/kg, twice weekly, prior to and during early pregnancy.

13.2 Animal Toxicology and/or Pharmacology

In a 26-week toxicology study, one out of 10 monkeys subcutaneously administered 45 mg/kg ustekinumab twice weekly for 26 weeks had a bacterial infection.

14 CLINICAL STUDIES

14.1 Psoriasis

Two multicenter, randomized, double-blind, placebo-controlled studies (Ps STUDY 1 and Ps STUDY 2) enrolled a total of 1996 subjects 18 years of age and older with plaque psoriasis who had a minimum body surface area involvement of 10%, and Psoriasis Area and Severity Index (PASI) score ≥ 12 , and who were candidates for phototherapy or systemic therapy. Subjects with guttate, erythrodermic, or pustular psoriasis were excluded from the studies.

Ps STUDY 1 enrolled 766 subjects and Ps STUDY 2 enrolled 1230 subjects. The studies had the same design through Week 28. In both studies, subjects were randomized in equal proportion to placebo, 45 mg or 90 mg of STELARA[®]. Subjects randomized to STELARA[®] received 45 mg or 90 mg doses, regardless of weight, at Weeks 0, 4, and 16. Subjects randomized to receive placebo at Weeks 0 and 4 crossed over to receive STELARA[®] (either 45 mg or 90 mg) at Weeks 12 and 16.

In both studies, the endpoints were the proportion of subjects who achieved at least a 75% reduction in PASI score (PASI 75) from baseline to Week 12 and treatment success (cleared or minimal) on the Physician's Global Assessment (PGA). The PGA is a 6-category scale ranging from 0 (cleared) to 5 (severe) that indicates the physician's overall assessment of psoriasis focusing on plaque thickness/induration, erythema, and scaling.

In both studies, subjects in all treatment groups had a median baseline PASI score ranging from approximately 17 to 18. Baseline PGA score was marked or severe in 44% of subjects in Ps STUDY 1 and 40% of subjects in Ps STUDY 2. Approximately two-thirds of all subjects had received prior phototherapy, 69% had received either prior conventional systemic or biologic therapy for the treatment of psoriasis, with 56% receiving prior conventional systemic therapy and 43% receiving prior biologic therapy. A total of 28% of subjects had a history of psoriatic arthritis.

Clinical Response

The results of Ps STUDY 1 and Ps STUDY 2 are presented in Table 7 below.

Table 7: Clinical Outcomes Ps STUDY 1 and Ps STUDY 2

Week 12	Ps STUDY 1			Ps STUDY 2		
	Placebo	STELARA®		Placebo	STELARA®	
		45 mg	90 mg		45 mg	90 mg
Subjects randomized	255	255	256	410	409	411
PASI 75 response	8 (3%)	171 (67%)	170 (66%)	15 (4%)	273 (67%)	311 (76%)
PGA of Cleared or Minimal	10 (4%)	151 (59%)	156 (61%)	18 (4%)	277 (68%)	300 (73%)

Examination of age, gender, and race subgroups did not identify differences in response to STELARA® among these subgroups.

In subjects who weighed 100 kg or less, response rates were similar with both the 45 mg and 90 mg doses; however, in subjects who weighed greater than 100 kg, higher response rates were seen with 90 mg dosing compared with 45 mg dosing (Table 8 below).

Table 8: Clinical Outcomes by Weight Ps STUDY 1 and Ps STUDY 2

	Ps STUDY 1			Ps STUDY 2		
	Placebo	STELARA®		Placebo	STELARA®	
		45 mg	90 mg		45 mg	90 mg
Subjects randomized	255	255	256	410	409	411
PASI 75 response at Week 12*						
≤100 kg	4%	74%	65%	4%	73%	78%
	6/166	124/168	107/164	12/290	218/297	225/289
>100 kg	2%	54%	68%	3%	49%	71%
	2/89	47/87	63/92	3/120	55/112	86/121
PGA of Cleared or Minimal at Week 12*						
≤100 kg	4%	64%	63%	5%	74%	75%
	7/166	108/168	103/164	14/290	220/297	216/289
>100 kg	3%	49%	58%	3%	51%	69%
	3/89	43/87	53/92	4/120	57/112	84/121

* Patients were dosed with study medication at Weeks 0 and 4.

Subjects in Ps STUDY 1 who were PASI 75 responders at both Weeks 28 and 40 were re-randomized at Week 40 to either continued dosing of STELARA® (STELARA® at Week 40) or to withdrawal of therapy (placebo at Week 40). At Week 52, 89% (144/162) of subjects re-randomized to STELARA® treatment were PASI 75 responders compared with 63% (100/159) of subjects re-randomized to placebo (treatment withdrawal after Week 28 dose). The median time to loss of PASI 75 response among the subjects randomized to treatment withdrawal was 16 weeks.

14.2 Adolescent Subjects with Plaque Psoriasis

A multicenter, randomized, double blind, placebo-controlled study (Ps STUDY 3) enrolled 110 adolescent subjects 12 to 17 years of age with a minimum BSA involvement of 10%, a PASI score greater than or equal to 12, and a PGA score greater than or equal to 3, who were candidates for phototherapy or systemic therapy and whose disease was inadequately controlled by topical therapy.

Subjects were randomized to receive placebo (n=37), the recommended dose of STELARA[®] (n=36), or one-half the recommended dose of STELARA[®] (n=37) by subcutaneous injection at Weeks 0 and 4 followed by dosing every 12 weeks (q12w). The recommended dose of STELARA[®] was 0.75 mg/kg for subjects weighing less than 60 kg, 45 mg for subjects weighing 60 kg to 100 kg, and 90 mg for subjects weighing greater than 100 kg. At Week 12, subjects who received placebo were crossed over to receive STELARA[®] at the recommended dose or one-half the recommended dose.

Of the adolescent subjects, approximately 63% had prior exposure to phototherapy or conventional systemic therapy and approximately 11% had prior exposure to biologics.

The endpoints were the proportion of patients who achieved a PGA score of cleared (0) or minimal (1), PASI 75, and PASI 90 at Week 12. Subjects were followed for up to 60 weeks following first administration of study agent.

Clinical Response

The efficacy results at Week 12 for Ps STUDY 3 are presented in Table 9.

Table 9: Summary of Efficacy Endpoints in the Adolescent Psoriasis Study at Week 12

	Ps STUDY 3	
	Placebo n (%)	STELARA ^{®*} n (%)
N	37	36
PGA		
PGA of cleared (0) or minimal (1)	2 (5.4%)	25 (69.4%)
PASI		
PASI 75 responders	4 (10.8%)	29 (80.6%)
PASI 90 responders	2 (5.4%)	22 (61.1%)

* Using the weight-based dosage regimen specified in Table 1 and Table 2.

14.3 Psoriatic Arthritis

The safety and efficacy of STELARA[®] was assessed in 927 patients (PsA STUDY 1, n=615; PsA STUDY 2, n=312), in two randomized, double-blind, placebo-controlled studies in adult patients 18 years of age and older with active PsA (≥5 swollen joints and ≥5 tender joints) despite non-steroidal anti-inflammatory (NSAID) or disease modifying antirheumatic (DMARD) therapy. Patients in these studies had a diagnosis of PsA for at least 6 months. Patients with each subtype of PsA were enrolled, including polyarticular arthritis with the absence of rheumatoid nodules (39%), spondylitis with peripheral arthritis (28%), asymmetric peripheral arthritis

(21%), distal interphalangeal involvement (12%) and arthritis mutilans (0.5%). Over 70% and 40% of the patients, respectively, had enthesitis and dactylitis at baseline.

Patients were randomized to receive treatment with STELARA[®] 45 mg, 90 mg, or placebo subcutaneously at Weeks 0 and 4 followed by every 12 weeks (q12w) dosing. Approximately 50% of patients continued on stable doses of MTX (≤ 25 mg/week). The primary endpoint was the percentage of patients achieving ACR 20 response at Week 24.

In PsA STUDY 1 and PsA STUDY 2, 80% and 86% of the patients, respectively, had been previously treated with DMARDs. In PsA STUDY 1, previous treatment with anti-tumor necrosis factor (TNF)- α agent was not allowed. In PsA STUDY 2, 58% (n=180) of the patients had been previously treated with TNF blocker, of whom over 70% had discontinued their TNF blocker treatment for lack of efficacy or intolerance at any time.

Clinical Response

In both studies, a greater proportion of patients achieved ACR 20, ACR 50 and PASI 75 response in the STELARA[®] 45 mg and 90 mg groups compared to placebo at Week 24 (see Table 10). ACR 70 responses were also higher in the STELARA[®] 45 mg and 90 mg groups, although the difference was only numerical (p=NS) in STUDY 2. Responses were similar in patients regardless of prior TNF α exposure.

Table 10: ACR 20, ACR 50, ACR 70 and PASI 75 responses in PsA STUDY 1 and PsA STUDY 2 at Week 24

	PsA STUDY 1			PsA STUDY 2		
	Placebo	STELARA [®] 45 mg	STELARA [®] 90 mg	Placebo	STELARA [®] 45 mg	STELARA [®] 90 mg
Number of patients randomized	206	205	204	104	103	105
ACR 20 response, N (%)	47 (23%)	87 (42%)	101 (50%)	21 (20%)	45 (44%)	46 (44%)
ACR 50 response, N (%)	18 (9%)	51 (25%)	57 (28%)	7 (7%)	18 (17%)	24 (23%)
ACR 70 response, N (%)	5 (2%)	25 (12%)	29 (14%)	3 (3%)	7 (7%)	9 (9%)
Number of patients with $\geq 3\%$ BSA^a	146	145	149	80	80	81
PASI 75 response, N (%)	16 (11%)	83 (57%)	93 (62%)	4 (5%)	41 (51%)	45 (56%)

^a Number of patients with $\geq 3\%$ BSA psoriasis skin involvement at baseline

The percent of patients achieving ACR 20 responses by visit is shown in Figure 1.

Figure 1: Percent of patients achieving ACR 20 response through Week 24
PsA STUDY 1

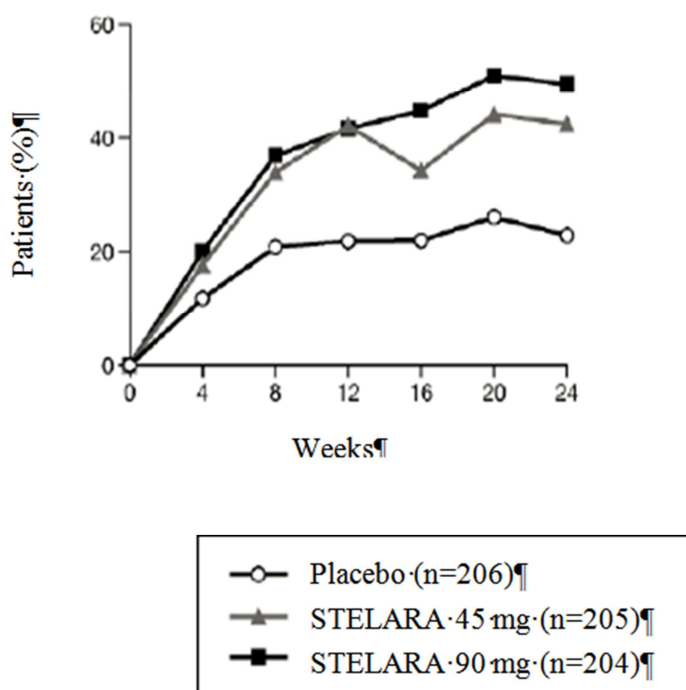

The results of the components of the ACR response criteria are shown in Table 11.

Table 11: Mean change from baseline in ACR components at Week 24

	PsA STUDY 1		
	Placebo (N=206)	STELARA® 45 mg (N=205)	90 mg (N=204)
Number of swollen joints ^a			
Baseline	15	12	13
Mean Change at Week 24	-3	-5	-6
Number of tender joints ^b			
Baseline	25	22	23
Mean Change at Week 24	-4	-8	-9
Patient's assessment of pain ^c			
Baseline	6.1	6.2	6.6
Mean Change at Week 24	-0.5	-2.0	-2.6
Patient global assessment ^c			
Baseline	6.1	6.3	6.4
Mean Change at Week 24	-0.5	-2.0	-2.5
Physician global assessment ^c			
Baseline	5.8	5.7	6.1
Mean Change at Week 24	-1.4	-2.6	-3.1
Disability index (HAQ) ^d			
Baseline	1.2	1.2	1.2

Mean Change at Week 24	-0.1	-0.3	-0.4
CRP (mg/dL) ^e			
Baseline	1.6	1.7	1.8
Mean Change at Week 24	0.01	-0.5	-0.8

^a Number of swollen joints counted (0-66)

^b Number of tender joints counted (0-68)

^c Visual analogue scale; 0= best, 10=worst.

^d Disability Index of the Health Assessment Questionnaire; 0 = best, 3 = worst, measures the patient's ability to perform the following: dress/groom, arise, eat, walk, reach, grip, maintain hygiene, and maintain daily activity.

^e CRP: (Normal Range 0.0-1.0 mg/dL)

An improvement in enthesitis and dactylitis scores was observed in each STELARA[®] group compared with placebo at Week 24.

Physical Function

STELARA[®]-treated patients showed improvement in physical function compared to patients treated with placebo as assessed by HAQ-DI at Week 24. In both studies, the proportion of HAQ-DI responders (≥ 0.3 improvement in HAQ-DI score) was greater in the STELARA[®] 45 mg and 90 mg groups compared to placebo at Week 24.

14.4 Crohn's Disease

STELARA[®] was evaluated in three randomized, double-blind, placebo-controlled clinical studies in adult patients with moderately to severely active Crohn's disease (Crohn's Disease Activity Index [CDAI] score of 220 to 450). There were two 8-week intravenous induction studies (CD-1 and CD-2) followed by a 44-week subcutaneous randomized withdrawal maintenance study (CD-3) representing 52 weeks of therapy. Patients in CD-1 had failed or were intolerant to treatment with one or more TNF blockers, while patients in CD-2 had failed or were intolerant to treatment with immunomodulators or corticosteroids, but never failed treatment with a TNF blocker.

Studies CD-1 and CD-2

In studies CD-1 and CD-2, 1409 patients were randomized, of whom 1368 (CD-1, n=741; CD-2, n=627) were included in the final efficacy analysis. Induction of clinical response (defined as a reduction in CDAI score of greater than or equal to 100 points or CDAI score of less than 150) at Week 6 and clinical remission (defined as a CDAI score of less than 150) at Week 8 were evaluated. In both studies, patients were randomized to receive a single intravenous administration of STELARA[®] at either approximately 6 mg/kg, placebo (see Table 3), or 130 mg (a lower dose than recommended).

In Study CD-1, patients had failed or were intolerant to prior treatment with a TNF blocker: 29% patients had an inadequate initial response (primary non-responders), 69% responded but subsequently lost response (secondary non-responders) and 36% were intolerant to a TNF blocker. Of these patients, 48% failed or were intolerant to one TNF blocker and 52% had failed 2 or 3 prior TNF blockers. At baseline and throughout the study, approximately 46% of the patients were receiving corticosteroids and 31% of the patients were receiving immunomodulators (AZA, 6-MP, MTX). The median baseline CDAI score was 319 in the STELARA[®] approximately 6 mg/kg group and 313 in the placebo group.

In Study CD-2, patients had failed or were intolerant to prior treatment with corticosteroids (81% of patients), at least one immunomodulator (6-MP, AZA, MTX; 68% of patients), or both (49% of patients). Additionally, 69% never received a TNF blocker and 31% previously received but had not failed a TNF blocker. At baseline, and throughout the study, approximately 39% of the patients were receiving corticosteroids and 35% of the patients were receiving immunomodulators (AZA, 6-MP, MTX). The median baseline CDAI score was 286 in the STELARA[®] and 290 in the placebo group.

In these induction studies, a greater proportion of patients treated with STELARA[®] (at the recommended dose of approximately 6 mg/kg dose) achieved clinical response at Week 6 and clinical remission at Week 8 compared to placebo (see Table 12 for clinical response and remission rates). Clinical response and remission were significant as early as Week 3 in STELARA[®]-treated patients and continued to improve through Week 8.

Table 12: Induction of Clinical Response and Remission in CD-1* and CD-2**

	CD-1 n=741			CD-2 n=627		
	Placebo N=247	STELARA [®] † N=249	Treatment difference and 95% CI	Placebo N=209	STELARA [®] † N=209	Treatment difference and 95% CI
Clinical Response (100 point), Week 6	53 (21%)	84 (34%) ^a	12% (4%, 20%)	60 (29%)	116 (56%) ^b	27% (18%, 36%)
Clinical Remission, Week 8	18 (7%)	52 (21%) ^b	14% (8%, 20%)	41 (20%)	84 (40%) ^b	21% (12%, 29%)
Clinical Response (100 point), Week 8	50 (20%)	94 (38%) ^b	18% (10%, 25%)	67 (32%)	121 (58%) ^b	26% (17%, 35%)
70 Point Response, Week 6	75 (30%)	109 (44%) ^a	13% (5%, 22%)	81 (39%)	135 (65%) ^b	26% (17%, 35%)
70 Point Response, Week 3	67 (27%)	101 (41%) ^a	13% (5%, 22%)	66 (32%)	106 (51%) ^b	19% (10%, 28%)

Clinical remission is defined as CDAI score < 150; Clinical response is defined as reduction in CDAI score by at least 100 points or being in clinical remission: 70 point response is defined as reduction in CDAI score by at least 70 points

* Patient population consisted of patients who failed or were intolerant to TNF blocker therapy

** Patient population consisted of patients who failed or were intolerant to corticosteroids or immunomodulators (e.g., 6-MP, AZA, MTX) and previously received but not failed a TNF blocker or were never treated with a TNF blocker.

† Infusion dose of STELARA[®] using the weight-based dosage regimen specified in Table 3.

^a 0.001 ≤ p < 0.01

^b p < 0.001

Study CD-3

The maintenance study (CD-3), evaluated 388 patients who achieved clinical response (≥100 point reduction in CDAI score) at Week 8 with either induction dose of STELARA[®] in studies CD-1 or CD-2. Patients were randomized to receive a subcutaneous maintenance regimen of either 90 mg STELARA[®] every 8 weeks or placebo for 44 weeks (see Table 13).

Table 13: Clinical Response and Remission in CD-3 (Week 44; 52 weeks from initiation of the induction dose)

	Placebo [*] N=131 [†]	90 mg STELARA [®] every 8 weeks N=128 [†]	Treatment difference and 95% CI
Clinical Remission	47 (36%)	68 (53%) ^a	17% (5%, 29%)

Clinical Response	58 (44%)	76 (59%) ^b	15% (3%, 27%)
Clinical Remission in patients in remission at the start of maintenance therapy ^{**}	36/79 (46%)	52/78 (67%) ^a	21% (6%, 36%)

Clinical remission is defined as CDAI score < 150; Clinical response is defined as reduction in CDAI of at least 100 points or being in clinical remission

* The placebo group consisted of patients who were in response to STELARA[®] and were randomized to receive placebo at the start of maintenance therapy.

** Patients in remission at the end of maintenance therapy who were in remission at the start of maintenance therapy. This does not account for any other time point during maintenance therapy.

† Patients who achieved clinical response to STELARA[®] at the end of the induction study.

a p < 0.01

b 0.01 ≤ p < 0.05

At Week 44, 47% of patients who received STELARA[®] were corticosteroid-free and in clinical remission, compared to 30% of patients in the placebo group.

At Week 0 of Study CD-3, 34/56 (61%) STELARA[®]-treated patients who previously failed or were intolerant to TNF blocker therapies were in clinical remission and 23/56 (41%) of these patients were in clinical remission at Week 44. In the placebo arm, 27/61 (44%) patients were in clinical remission at Week 0 while 16/61 (26%) of these patients were in remission at Week 44.

At Week 0 of Study CD-3, 46/72 (64%) STELARA[®]-treated patients who had previously failed immunomodulator therapy or corticosteroids (but not TNF blockers) were in clinical remission and 45/72 (63%) of these patients were in clinical remission at Week 44. In the placebo arm, 50/70 (71%) of these patients were in clinical remission at Week 0 while 31/70 (44%) were in remission at Week 44. In the subset of these patients who were also naïve to TNF blockers, 34/52 (65%) of STELARA[®]-treated patients were in clinical remission at Week 44 as compared to 25/51 (49%) in the placebo arm.

Patients who were not in clinical response 8 weeks after STELARA[®] induction were not included in the primary efficacy analyses for Study CD-3; however, these patients were eligible to receive a 90 mg subcutaneous injection of STELARA[®] upon entry into Study CD-3. Of these patients, 102/219 (47%) achieved clinical response eight weeks later and were followed for the duration of the study.

14.5 Ulcerative Colitis

STELARA[®] was evaluated in two randomized, double-blind, placebo-controlled clinical studies [UC-1 and UC-2 (NCT02407236)] in adult patients with moderately to severely active ulcerative colitis who had an inadequate response to or failed to tolerate a biologic (i.e., TNF blocker and/or vedolizumab), corticosteroids, and/or 6-MP or AZA therapy. The 8-week intravenous induction study (UC-1) was followed by the 44-week subcutaneous randomized withdrawal maintenance study (UC-2) for a total of 52 weeks of therapy.

Disease assessment was based on the Mayo score, which ranged from 0 to 12 and has four subscores that were each scored from 0 (normal) to 3 (most severe): stool frequency, rectal bleeding, findings on centrally-reviewed endoscopy, and physician global assessment. Moderately to severely active ulcerative colitis was defined at baseline (Week 0) as Mayo score of 6 to 12, including a Mayo endoscopy subscore ≥ 2. An endoscopy score of 2 was defined by marked erythema, absent vascular pattern, friability, erosions; and a score of 3 was defined by spontaneous bleeding, ulceration. At baseline, patients had a median Mayo score of 9, with 84%

of patients having moderate disease (Mayo score 6-10) and 15% having severe disease (Mayo score 11-12).

Patients in these studies may have received other concomitant therapies including aminosalicylates, immunomodulatory agents (AZA, 6-MP, or MTX), and oral corticosteroids (prednisone).

Study UC-1

In UC-1, 961 patients were randomized at Week 0 to a single intravenous administration of STELARA[®] of approximately 6 mg/kg, 130 mg (a lower dose than recommended), or placebo. Patients enrolled in UC-1 had to have failed therapy with corticosteroids, immunomodulators or at least one biologic. A total of 51% had failed at least one biologic and 17% had failed both a TNF blocker and an integrin receptor blocker. Of the total population, 46% had failed corticosteroids or immunomodulators but were biologic-naïve and an additional 3% had previously received but had not failed a biologic. At induction baseline and throughout the study, approximately 52% patients were receiving oral corticosteroids, 28% patients were receiving immunomodulators (AZA, 6-MP, or MTX) and 69% patients were receiving aminosalicylates.

The primary endpoint was clinical remission at Week 8. Clinical remission with a definition of: Mayo stool frequency subscore of 0 or 1, Mayo rectal bleeding subscore of 0 (no rectal bleeding), and Mayo endoscopy subscore of 0 or 1 (Mayo endoscopy subscore of 0 defined as normal or inactive disease and Mayo subscore of 1 defined as presence of erythema, decreased vascular pattern and no friability) is provided in Table 14.

The secondary endpoints were clinical response, endoscopic improvement, and histologic-endoscopic mucosal improvement. Clinical response with a definition of (≥ 2 points and $\geq 30\%$ decrease in modified Mayo score, defined as 3-component Mayo score without the Physician's Global Assessment, with either a decrease from baseline in the rectal bleeding subscore ≥ 1 or a rectal bleeding subscore of 0 or 1), endoscopic improvement with a definition of Mayo endoscopy subscore of 0 or 1, and histologic-endoscopic mucosal improvement with a definition of combined endoscopic improvement and histologic improvement of the colon tissue [neutrophil infiltration in $<5\%$ of crypts, no crypt destruction, and no erosions, ulcerations, or granulation tissue]) are provided in Table 14.

In UC-1, a significantly greater proportion of patients treated with STELARA[®] (at the recommended dose of approximately 6 mg/kg dose) were in clinical remission and response and achieved endoscopic improvement and histologic-endoscopic mucosal improvement compared to placebo (see Table 14).

Table 14: Proportion of Patients Meeting Efficacy Endpoints at Week 8 in UC-1

Endpoint	Placebo N=319		STELARA ^{®†} N=322		Treatment difference and 97.5% CI ^a
	N	%	N	%	
Clinical Remission[*]	22	7%	62	19%	12% (7%, 18%) ^b
Bio-naïve [□]	14/151	9%	36/147	24%	

Prior biologic failure	7/161	4%	24/166	14%	
Endoscopic Improvement[§]	40	13%	80	25%	12% (6%, 19%) ^b
Bio-naïve [□]	28/151	19%	43/147	29%	
Prior biologic failure	11/161	7%	34/166	20%	
Clinical Response[†]	99	31%	186	58%	27% (18%, 35%) ^b
Bio-naïve [□]	55/151	36%	94/147	64%	
Prior biologic failure	42/161	26%	86/166	52%	
Histologic-Endoscopic Mucosal Improvement	26	8%	54	17%	9% (3%, 14%) ^b
Bio-naïve [□]	19/151	13%	30/147	20%	
Prior biologic failure	6/161	4%	21/166	13%	

[†] Infusion dose of STELARA[®] using the weight-based dosage regimen specified in Table 3.

[□] An additional 7 patients on placebo and 9 patients on STELARA[®] (6 mg/kg) had been exposed to, but had not failed, biologics.

^{*} Clinical remission was defined as Mayo stool frequency subscore of 0 or 1, Mayo rectal bleeding subscore of 0, and Mayo endoscopy subscore of 0 or 1 (modified so that 1 does not include friability).

[§] Endoscopic improvement was defined as Mayo endoscopy subscore of 0 or 1 (modified so that 1 does not include friability).

[†] Clinical response was defined as a decrease from baseline in the modified Mayo score by $\geq 30\%$ and ≥ 2 points, with either a decrease from baseline in the rectal bleeding subscore ≥ 1 or a rectal bleeding subscore of 0 or 1.

[‡] Histologic-endoscopic mucosal improvement was defined as combined endoscopic improvement (Mayo endoscopy subscore of 0 or 1) and histologic improvement of the colon tissue (neutrophil infiltration in $<5\%$ of crypts, no crypt destruction, and no erosions, ulcerations, or granulation tissue).

^a Adjusted treatment difference (97.5% CI)

^b $p < 0.001$

The relationship of histologic-endoscopic mucosal improvement, as defined in UC-1, at Week 8 to disease progression and long-term outcomes was not evaluated during UC-1.

Rectal Bleeding and Stool Frequency Subscores

Decreases in rectal bleeding and stool frequency subscores were observed as early as Week 2 in STELARA[®]-treated patients.

Study UC-2

The maintenance study (UC-2) evaluated 523 patients who achieved clinical response 8 weeks following the intravenous administration of either induction dose of STELARA[®] in UC-1. These patients were randomized to receive a subcutaneous maintenance regimen of either 90 mg STELARA[®] every 8 weeks, or every 12 weeks (a lower dose than recommended), or placebo for 44 weeks.

The primary endpoint was the proportion of patients in clinical remission at Week 44. The secondary endpoints included the proportion of patients maintaining clinical response at Week 44, the proportion of patients with endoscopic improvement at Week 44, the proportion of patients with corticosteroid-free clinical remission at Week 44, and the proportion of patients maintaining clinical remission at Week 44 among patients who achieved clinical remission 8 weeks after induction.

Results of the primary and secondary endpoints at Week 44 in patients treated with STELARA[®] at the recommended dosage (90 mg every 8 weeks) compared to the placebo are shown in Table 15.

Table 15: Efficacy Endpoints of Maintenance at Week 44 in UC-2 (52 Weeks from Initiation of the Induction Dose)

Endpoint	Placebo* N=175 [†]		90 mg STELARA [®] every 8 weeks N=176		Treatment difference and 95% CI
	N	%	N	%	
Clinical Remission**	46	26%	79	45%	19% (9%, 28%) ^a
Bio-naïve [□]	30/84	36%	39/79	49%	
Prior biologic failure	16/88	18%	37/91	41%	
Maintenance of Clinical Response at Week 44[†]	84	48%	130	74%	26% (16%, 36%) ^a
Bio-naïve [□]	49/84	58%	62/79	78%	
Prior biologic failure	35/88	40%	64/91	70%	
Endoscopic Improvement[§]	47	27%	83	47%	20% (11%, 30%) ^a
Bio-naïve [□]	29/84	35%	42/79	53%	
Prior biologic failure	18/88	20%	38/91	42%	
Corticosteroid-free Clinical Remission[‡]	45	26%	76	43%	17% (8%, 27%) ^a
Bio-naïve [□]	30/84	36%	38/79	48%	
Prior biologic failure	15/88	17%	35/91	38%	
Maintenance of Clinical Remission at Week 44 in patients who achieved clinical remission 8 weeks after induction	18/50	36%	27/41	66%	31% (12%, 50%) ^b
Bio-naïve [□]	12/27	44%	14/20	70%	
Prior biologic failure	6/23	26%	12/18	67%	

[□] An additional 3 patients on placebo and 6 patients on STELARA[®] had been exposed to, but had not failed, biologics.

*The placebo group consisted of patients who were in response to STELARA[®] and were randomized to receive placebo at the start of maintenance therapy.

**Clinical remission was defined as Mayo stool frequency subscore of 0 or 1, Mayo rectal bleeding subscore of 0, and Mayo endoscopy subscore of 0 or 1 (modified so that 1 does not include friability).

[†] Clinical response was defined as a decrease from baseline in the modified Mayo score by $\geq 30\%$ and ≥ 2 points, with either a decrease from baseline in the rectal bleeding subscore ≥ 1 or a rectal bleeding subscore of 0 or 1.

[§] Endoscopic improvement was defined as Mayo endoscopy subscore of 0 or 1 (modified so that 1 does not include friability).

[‡] Corticosteroid-free clinical remission was defined as patients in clinical remission and not receiving corticosteroids at Week 44.

^a $p < 0.001$

^b $p = 0.004$

Other Endpoints

Week 16 Responders to Ustekinumab Induction

Patients who were not in clinical response 8 weeks after induction with STELARA[®] in UC-1 were not included in the primary efficacy analyses for Study UC-2; however, these patients were eligible to receive a 90 mg subcutaneous injection of STELARA[®] at Week 8. Of these patients, 55/101 (54%) achieved clinical response eight weeks later (Week 16) and received STELARA[®] 90 mg subcutaneously every 8 weeks during the UC-2 trial. At Week 44, there were 97/157 (62%) patients who maintained clinical response and there were 51/157 (32%) who achieved clinical remission.

Histologic-Endoscopic Mucosal Improvement at Week 44

The proportion of patients achieving histologic-endoscopic mucosal improvement during maintenance treatment in UC-2 was 75/172 (44%) among patients on STELARA[®] and 40/172 (23%) in patients on placebo at Week 44. The relationship of histologic-endoscopic mucosal improvement, as defined in UC-2, at Week 44 to progression of disease or long-term outcomes was not evaluated in UC-2.

Endoscopic Normalization

Normalization of endoscopic appearance of the mucosa was defined as a Mayo endoscopic subscore of 0. At Week 8 in UC-1, endoscopic normalization was achieved in 25/322 (8%) of patients treated with STELARA[®] and 12/319 (4%) of patients in the placebo group. At Week 44 of UC-2, endoscopic normalization was achieved in 51/176 (29%) of patients treated with STELARA[®] and in 32/175 (18%) of patients in placebo group.

15 REFERENCES

- ¹ Surveillance, Epidemiology, and End Results (SEER) Program (www.seer.cancer.gov) SEER*Stat Database: Incidence - SEER 6.6.2 Regs Research Data, Nov 2009 Sub (1973-2007) - Linked To County Attributes - Total U.S., 1969-2007 Counties, National Cancer Institute, DCCPS, Surveillance Research Program, Surveillance Systems Branch, released April 2010, based on the November 2009 submission.

16 HOW SUPPLIED/STORAGE AND HANDLING

STELARA[®] (ustekinumab) injection is a sterile, preservative-free, colorless to light yellow solution and may contain a few small translucent or white particles. It is supplied as individually packaged, single-dose prefilled syringes or single-dose vials.

For Subcutaneous Use

Prefilled Syringes

- 45 mg/0.5 mL (NDC 57894-060-03)
- 90 mg/mL (NDC 57894-061-03)

Each prefilled syringe is equipped with a 27 gauge fixed ½ inch needle, a needle safety guard, and a needle cover that contains dry natural rubber.

Single-dose Vial

- 45 mg/0.5 mL (NDC 57894-060-02)

For Intravenous Infusion

Single-dose Vial

- 130 mg/26 mL (5 mg/mL) (NDC 57894-054-27)

Storage and Stability

STELARA[®] vials and prefilled syringes must be refrigerated at 2°C to 8°C (36°F to 46°F). Store STELARA[®] vials upright. Keep the product in the original carton to protect from light until the time of use. Do not freeze. Do not shake.

If needed, individual prefilled syringes may be stored at room temperature up to 30°C (86°F) for a maximum single period of up to 30 days in the original carton to protect from light. Record the date when the prefilled syringe is first removed from the refrigerator on the carton in the space provided. Once a syringe has been stored at room temperature, it should not be returned to the refrigerator. Discard the syringe if not used within 30 days at room temperature storage. Do not use STELARA[®] after the expiration date on the carton or on the prefilled syringe.

17 PATIENT COUNSELING INFORMATION

Advise the patient and/or caregiver to read the FDA-approved patient labeling (Medication Guide and Instructions for Use).

Infections

Inform patients that STELARA[®] may lower the ability of their immune system to fight infections and to contact their healthcare provider immediately if they develop any signs or symptoms of infection [*see Warnings and Precautions (5.1)*].

Malignancies

Inform patients of the risk of developing malignancies while receiving STELARA[®] [*see Warnings and Precautions (5.4)*].

Hypersensitivity Reactions

- Advise patients to seek immediate medical attention if they experience any signs or symptoms of serious hypersensitivity reactions and discontinue STELARA[®] [*see Warnings and Precautions (5.5)*].
- Inform patients the needle cover on the prefilled syringe contains dry natural rubber (a derivative of latex), which may cause allergic reactions in individuals sensitive to latex [*see Dosage and Administration (2.4)*].

Immunizations

Inform patients that STELARA[®] can interfere with the usual response to immunizations and that they should avoid live vaccines [*see Warnings and Precautions (5.7)*].

Administration

Instruct patients to follow sharps disposal recommendations, as described in the Instructions for Use.

Prefilled Syringe Manufactured by: Janssen Biotech, Inc., Horsham, PA 19044, US License No. 1864 at Baxter Pharmaceutical Solutions, Bloomington, IN 47403 and at Cilag AG, Schaffhausen, Switzerland

Vial Manufactured by: Janssen Biotech, Inc., Horsham, PA 19044, US License No. 1864 at Cilag AG, Schaffhausen, Switzerland

© 2012, 2016, 2019 Janssen Pharmaceutical Companies

MEDICATION GUIDE

STELARA[®] (stel ar' a)

(ustekinumab)

injection, for subcutaneous or intravenous use

What is the most important information I should know about STELARA?

STELARA is a medicine that affects your immune system. STELARA can increase your risk of having serious side effects, including:

Serious infections. STELARA may lower the ability of your immune system to fight infections and may increase your risk of infections. Some people have serious infections while taking STELARA, including tuberculosis (TB), and infections caused by bacteria, fungi, or viruses. Some people have to be hospitalized for treatment of their infection.

- Your doctor should check you for TB before starting STELARA.
- If your doctor feels that you are at risk for TB, you may be treated with medicine for TB before you begin treatment with STELARA and during treatment with STELARA.
- Your doctor should watch you closely for signs and symptoms of TB while you are being treated with STELARA.

You should not start taking STELARA if you have any kind of infection unless your doctor says it is okay.

Before starting STELARA, tell your doctor if you:

- think you have an infection or have symptoms of an infection such as:
 - fever, sweat, or chills
 - muscle aches
 - cough
 - shortness of breath
 - blood in phlegm
 - weight loss
 - warm, red, or painful skin or sores on your body
 - diarrhea or stomach pain
 - burning when you urinate or urinate more often than normal
 - feel very tired
- are being treated for an infection or have any open cuts.
- get a lot of infections or have infections that keep coming back.
- have TB, or have been in close contact with someone with TB.

After starting STELARA, call your doctor right away if you have any symptoms of an infection (see above). These may be signs of infections such as chest infections, or skin infections or shingles that could have serious complications. STELARA can make you more likely to get infections or make an infection that you have worse.

People who have a genetic problem where the body does not make any of the proteins interleukin 12 (IL-12) and interleukin 23 (IL-23) are at a higher risk for certain serious infections. These infections can spread throughout the body and cause death. People who take STELARA may also be more likely to get these infections.

Cancers. STELARA may decrease the activity of your immune system and increase your risk for certain types of cancers. Tell your doctor if you have ever had any type of cancer. Some people who are receiving STELARA and have risk factors for skin cancer have developed certain types of skin cancers. During your treatment with STELARA, tell your doctor if you develop any new skin growths.

Reversible Posterior Leukoencephalopathy Syndrome (RPLS). RPLS is a rare condition that affects the brain and can cause death. The cause of RPLS is not known. If RPLS is found early and treated, most people recover. Tell your doctor right away if you have any new or worsening medical problems including:

- headache
- seizures
- confusion
- vision problems

What is STELARA?

STELARA is a prescription medicine used to treat:

- adults and children 12 years and older with moderate or severe psoriasis who may benefit from taking injections or pills (systemic therapy) or phototherapy (treatment using ultraviolet light alone or with pills).
- adults 18 years and older with active psoriatic arthritis. STELARA can be used alone or with the medicine methotrexate.
- adults 18 years and older with moderately to severely active Crohn's disease.
- adults 18 years and older with moderately to severely active ulcerative colitis.

It is not known if STELARA is safe and effective in children less than 12 years of age.

Do not take STELARA if you are allergic to ustekinumab or any of the ingredients in STELARA. See the end of this Medication Guide for a complete list of ingredients in STELARA.

Before you receive STELARA, tell your doctor about all of your medical conditions, including if you:

- have any of the conditions or symptoms listed in the section "What is the most important information I should

know about STELARA?”

- ever had an allergic reaction to STELARA. Ask your doctor if you are not sure.
- are allergic to latex. The needle cover on the prefilled syringe contains latex.
- have recently received or are scheduled to receive an immunization (vaccine). People who take STELARA should not receive live vaccines. Tell your doctor if anyone in your house needs a live vaccine. The viruses used in some types of live vaccines can spread to people with a weakened immune system, and can cause serious problems. **You should not receive the BCG vaccine during the one year before receiving STELARA or one year after you stop receiving STELARA.**
- have any new or changing lesions within psoriasis areas or on normal skin.
- are receiving or have received allergy shots, especially for serious allergic reactions. Allergy shots may not work as well for you during treatment with STELARA. STELARA may also increase your risk of having an allergic reaction to an allergy shot.
- receive or have received phototherapy for your psoriasis.
- are pregnant or plan to become pregnant. It is not known if STELARA can harm your unborn baby. You and your doctor should decide if you will receive STELARA.
- are breastfeeding or plan to breastfeed. It is thought that STELARA passes into your breast milk in small amounts.
- Talk to your doctor about the best way to feed your baby if you receive STELARA.

Tell your doctor about all the medicines you take, including prescription and over-the-counter medicines, vitamins, and herbal supplements.

Know the medicines you take. Keep a list of them to show your doctor and pharmacist when you get a new medicine.

How should I use STELARA?

- Use STELARA exactly as your doctor tells you to.
- **The needle cover on the STELARA prefilled syringe contains latex. Do not handle the needle cover if you are sensitive to latex.**
- Adults with Crohn’s disease and ulcerative colitis will receive the first dose of STELARA through a vein in the arm (intravenous infusion) in a healthcare facility by a healthcare provider. It takes at least 1 hour to receive the full dose of medicine. You will then receive STELARA as an injection under the skin (subcutaneous injection) 8 weeks after the first dose of STELARA, as described below.
- Adults with psoriasis or psoriatic arthritis and children 12 years and older with psoriasis will receive STELARA as an injection under the skin (subcutaneous injection) as described below.
- **Injecting STELARA under your skin**
 - STELARA is intended for use under the guidance and supervision of your doctor. In children 12 years and older, it is recommended that STELARA be administered by a healthcare provider. If your doctor decides that you or a caregiver may give your injections of STELARA at home, you should receive training on the right way to prepare and inject STELARA. Your doctor will determine the right dose of STELARA for you, the amount for each injection, and how often you should receive it. Do not try to inject STELARA yourself until you or your caregiver have been shown how to inject STELARA by your doctor or nurse.
 - Inject STELARA under the skin (subcutaneous injection) in your upper arms, buttocks, upper legs (thighs) or stomach area (abdomen).
 - Do not give an injection in an area of the skin that is tender, bruised, red or hard.
 - Use a different injection site each time you use STELARA.
 - If you inject more STELARA than prescribed, call your doctor right away.
 - Be sure to keep all of your scheduled follow-up appointments.

Read the detailed Instructions for Use at the end of this Medication Guide for instructions about how to prepare and inject a dose of STELARA, and how to properly throw away (dispose of) used needles and syringes. The syringe, needle and vial must never be re-used. After the rubber stopper is punctured, STELARA can become contaminated by harmful bacteria which could cause an infection if re-used. Therefore, throw away any unused portion of STELARA.

What should I avoid while using STELARA?

You should not receive a live vaccine while taking STELARA. See “**Before you receive STELARA, tell your doctor about all of your medical conditions, including if you:**”

What are the possible side effects of STELARA?

STELARA may cause serious side effects, including:

- See “**What is the most important information I should know about STELARA?**”
- **Serious allergic reactions.** Serious allergic reactions can occur with STELARA. Stop using STELARA and get

medical help right away if you have any of the following symptoms of a serious allergic reaction:

- feeling faint
- swelling of your face, eyelids, tongue, or throat
- chest tightness
- skin rash
- **Lung inflammation.** Cases of lung inflammation have happened in some people who receive STELARA, and may be serious. These lung problems may need to be treated in a hospital. Tell your doctor right away if you develop shortness of breath or a cough that doesn't go away during treatment with STELARA.

Common side effects of STELARA include:

- nasal congestion, sore throat, and runny nose
- upper respiratory infections
- fever
- headache
- tiredness
- itching
- nausea and vomiting
- redness at the injection site
- vaginal yeast infections
- urinary tract infections
- sinus infection
- bronchitis
- diarrhea
- stomach pain

These are not all of the possible side effects of STELARA. Call your doctor for medical advice about side effects. You may report side effects to FDA at 1-800-FDA-1088.

You may also report side effects to Janssen Biotech, Inc. at 1-800 JANSSEN (1-800-526-7736).

How should I store STELARA?

- Store STELARA vials and prefilled syringes in a refrigerator between 36°F to 46°F (2°C to 8°C).
- Store STELARA vials standing up straight.
- Store STELARA in the original carton to protect it from light until time to use it.
- Do not freeze STELARA.
- Do not shake STELARA.

If needed, individual STELARA prefilled syringes may also be stored at room temperature up to 30°C (86°F) for a maximum single period of up to 30 days in the original carton to protect from light. Record the date when the prefilled syringe is first removed from the refrigerator on the carton in the space provided. Once a syringe has been stored at room temperature, it should not be returned to the refrigerator. Discard the syringe if not used within 30 days at room temperature storage. Do not use STELARA after the expiration date on the carton or on the prefilled syringe.

Keep STELARA and all medicines out of the reach of children.

General information about the safe and effective use of STELARA.

Medicines are sometimes prescribed for purposes other than those listed in a Medication Guide. Do not use STELARA for a condition for which it was not prescribed. Do not give STELARA to other people, even if they have the same symptoms that you have. It may harm them. You can ask your doctor or pharmacist for information about STELARA that was written for health professionals.

What are the ingredients in STELARA?

Active ingredient: ustekinumab

Inactive ingredients: **Single-dose prefilled syringe for subcutaneous use** contains L-histidine, L-histidine monohydrochloride monohydrate, Polysorbate 80, and sucrose. **Single-dose vial for subcutaneous use** contains L-histidine, L-histidine hydrochloride monohydrate, Polysorbate 80 and sucrose. **Single-dose vial for intravenous infusion** contains EDTA disodium salt dihydrate, L-histidine, L-histidine hydrochloride monohydrate, L-methionine, Polysorbate 80, and sucrose.

Manufactured by: Janssen Biotech, Inc., Horsham, PA 19044, US License No. 1864

© 2012, 2016, 2019 Janssen Pharmaceutical Companies

For more information, go to www.stelarainfo.com or call 1-800-JANSSEN (1-800-526-7736).

This Medication Guide has been approved by the U.S. Food and Drug Administration

Revised: MM/YYYY

INSTRUCTIONS FOR USE
STELARA (stel ar' a)
(ustekinumab)
injection, for subcutaneous use

Instructions for injecting STELARA using a prefilled syringe.

Read this Instructions for Use before you start using STELARA. Your doctor or nurse should show you how to prepare and give your injection of STELARA the right way.

If you cannot give yourself the injection:

- ask your doctor or nurse to help you, or
- ask someone who has been trained by a doctor or nurse to give your injections.

Do not try to inject STELARA yourself until you have been shown how to inject STELARA by your doctor, nurse or health professional.

Important information:

- Before you start, check the carton to make sure that it is the right dose. You will have either 45 mg or 90 mg as prescribed by your doctor.
 - If your dose is 45 mg, you will receive one 45 mg prefilled syringe.
 - If your dose is 90 mg, you will receive either one 90 mg prefilled syringe or two 45 mg prefilled syringes. **If you receive two 45 mg prefilled syringes for a 90 mg dose, you will need to give yourself two injections, one right after the other.**
- Children 12 years of age and older with psoriasis who weigh 132 pounds or more may use a prefilled syringe.
- Check the expiration date on the prefilled syringe and carton. If the expiration date has passed or if the prefilled syringe has been kept at room temperature up to 30°C (86°F) for longer than a maximum single period of 30 days or if the prefilled syringe has been stored above 30°C (86°F), do not use it. If the expiration date has passed or if the prefilled syringe has been stored above 30°C (86°F), call your doctor or pharmacist, or call 1-800-JANSSEN (1-800-526-7736) for help.
- Make sure the syringe is not damaged.
- **The needle cover on the prefilled syringe contains latex. Do not handle the needle cover on the STELARA prefilled syringe if you are allergic to latex.**
- Check your prefilled syringe for any particles or discoloration. Your prefilled syringe should look clear and colorless to light yellow with few white particles.
- Do not use if it is frozen, discolored, cloudy or has large particles. Get a new prefilled syringe.
- **Do not shake the prefilled syringe at any time.** Shaking your prefilled syringe may damage your STELARA medicine. If your prefilled syringe has been shaken, do not use it. Get a new prefilled syringe.
- To reduce the risk of accidental needle sticks, each prefilled syringe has a needle guard that is automatically activated to cover the needle after you have given your injection. Do not pull back on the plunger at any time.

Gather the supplies you will need to prepare and to give your injection. (See Figure A)

You will need:

- antiseptic wipes
- cotton balls or gauze pads
- adhesive bandage
- your prescribed dose of STELARA (See Figure B)
- FDA-cleared sharps disposal container. See "Step 4: Dispose of the syringe."

Figure A

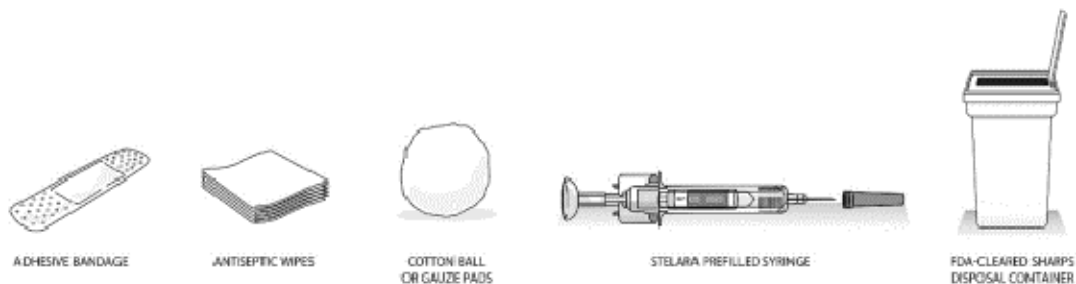
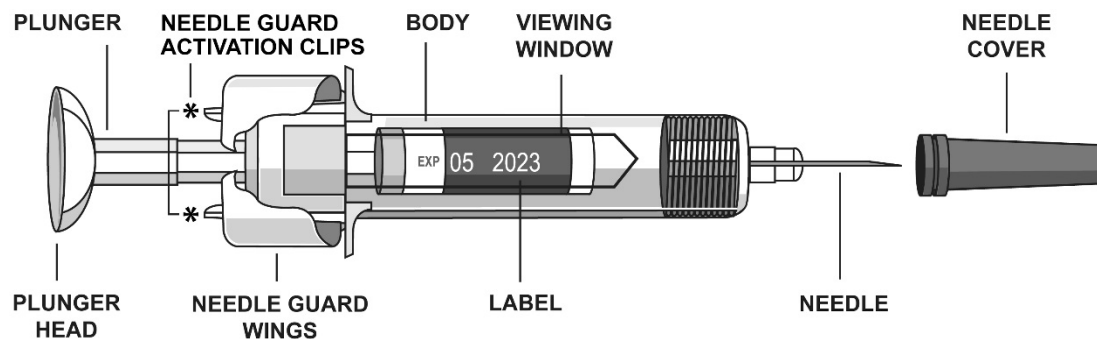

Figure B

To prevent early activation of the needle safety guard, do not touch the **NEEDLE GUARD ACTIVATION CLIPS** at any time during use.



Step 1: Prepare the injection.

- Choose a well-lit, clean, flat work surface.
- Wash your hands well with soap and warm water.
- Hold the prefilled syringe with the covered needle pointing upward.

Step 2: Prepare your injection site

- Choose an injection site around your stomach area (abdomen), buttocks, upper legs (thighs). If a caregiver is giving you the injection, the outer area of the upper arms may also be used. (See Figure C)
- **Use a different injection site for each injection. Do not** give an injection in an area of the skin that is tender, bruised, red or hard.
- Clean the skin with an antiseptic wipe where you plan to give your injection.

- **Do not** touch this area again before giving the injection. Let your skin dry before injecting.
- **Do not** fan or blow on the clean area.

Figure C

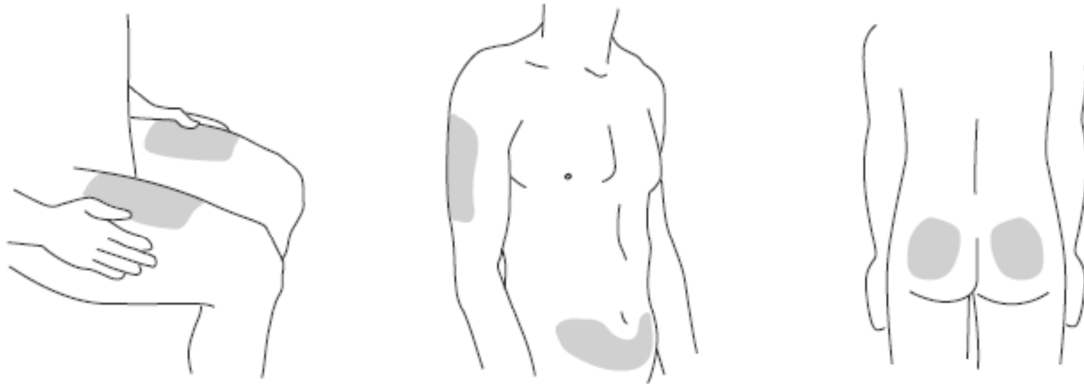

*Areas in gray are recommended injection sites.

Step 3: Inject STELARA

- Remove the needle cover when you are ready to inject your STELARA.
- **Do not** touch the plunger while removing the needle cover.
- Hold the body of the prefilled syringe with one hand, and pull the needle cover straight off. **(see Figure D)**
- Put the needle cover in the trash.
- You may also see a drop of liquid at the end of the needle. This is normal.
- **Do not** touch the needle or let it touch anything.
- **Do not** use the prefilled syringe if it is dropped without the needle cover in place. Call your doctor, nurse or health professional for instructions.

Figure D

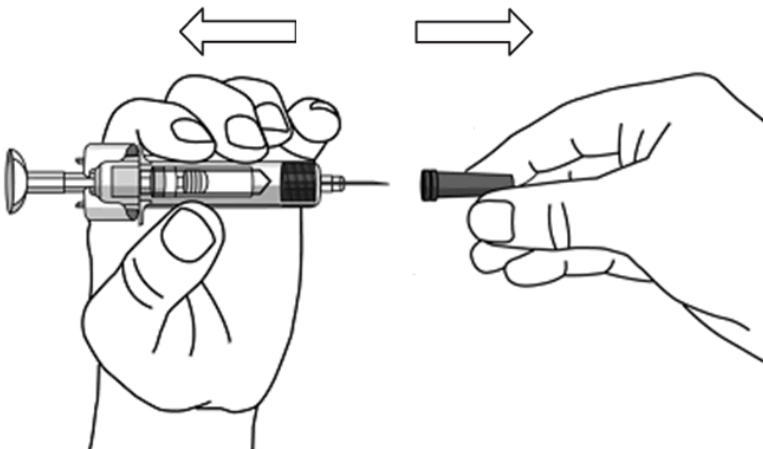

- Hold the body of the prefilled syringe in one hand between the thumb and index fingers. **(See Figure E)**

Figure E



- **Do not** pull back on the plunger at any time.
- Use the other hand to gently pinch the cleaned area of skin. Hold firmly.
- Use a quick, dart-like motion to insert the needle into the pinched skin at about a 45-degree angle. **(See Figure F)**

Figure F

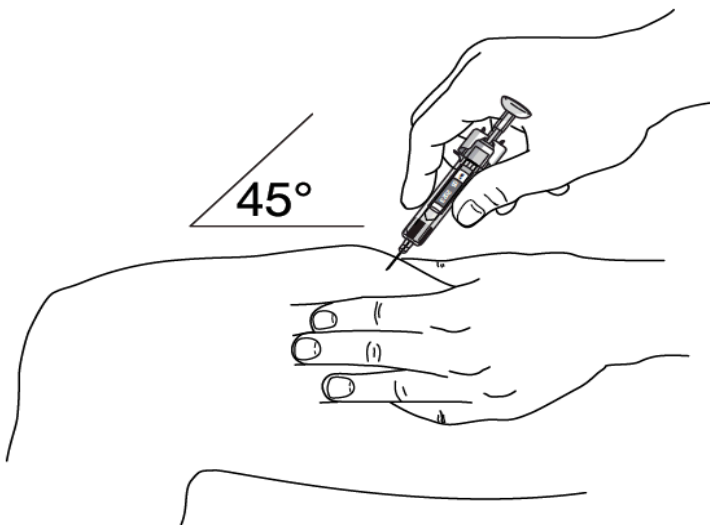

- Inject all of the liquid by using your thumb to push in the plunger until the plunger head is completely between the needle guard wings. **(See Figure G)**

Figure G

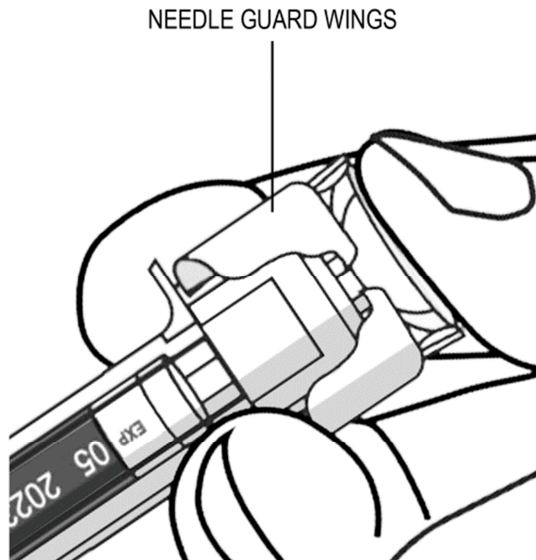

- When the plunger is pushed as far as it will go, keep pressure on the plunger head. Take the needle out of the skin and let go of the skin.
- Slowly take your thumb off the plunger head. This will let the empty syringe move up until the entire needle is covered by the needle guard. (**See Figure H**)

Figure H

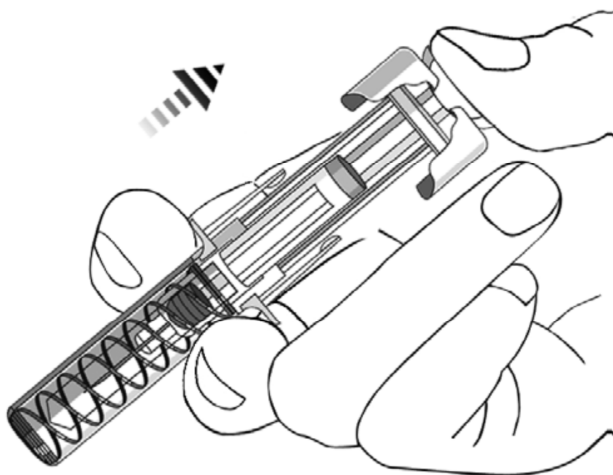

- When the needle is pulled out of your skin, there may be a little bleeding at the injection site. This is normal. You can press a cotton ball or gauze pad to the injection site if needed. Do not rub the injection site. You may cover the injection site with a small adhesive bandage, if necessary.

If your dose is 90 mg, you will receive either one 90 mg prefilled syringe or two 45 mg prefilled syringes. If you receive two 45 mg prefilled syringes for a 90 mg dose, you will need to give yourself a second injection right after the first. Repeat Steps 1-3 for the second injection using a new syringe. Choose a different site for the second injection.

Step 4: Dispose of the syringe.

- Put the syringe in a FDA-cleared sharps disposal container right away after use. **Do not throw away (dispose of) loose syringes in your household trash.**
- If you do not have a FDA-cleared sharps disposal container, you may use a household container that is:
 - made of heavy-duty plastic.
 - can be closed with a tight-fitting, puncture-resistant lid, without sharps being able to come out.
 - upright and stable during use,
 - leak-resistant,
 - and properly labeled to warn of hazardous waste inside the container.
- When your sharps disposal container is almost full, you will need to follow your community guidelines for the right way to dispose of your sharps disposal container. There may be local or state laws about how to throw away syringes and needles. For more information about safe sharps disposal, and for specific information about sharps disposal in the state that you live in, go to the FDA's website at: <http://www.fda.gov/safesharpsdisposal>.
- Do not dispose of your sharps disposal container in your household trash unless your community guidelines permit this. Do not recycle your sharps disposal container.
- If you have any questions, talk to your doctor or pharmacist.

Keep STELARA and all medicines out of the reach of children.

Prefilled Syringe Manufactured by:
Janssen Biotech, Inc., Horsham, PA 19044, US License No. 1864 at Baxter
Pharmaceutical Solutions, Bloomington, IN 47403 and at Cilag AG, Schaffhausen,
Switzerland

This Instructions for Use has been approved by the U.S. Food and Drug Administration.

Revised: MM/YYYY

© 2012 Janssen Pharmaceutical Companies



Box		Global Graphic Services		janssen	
STELARA		Inge Vermeiren: Tel.: +32 (0)14606915 - E-mail: ivermei1@its.jnj.com Shared mailbox: RA-JANBE-GRAPHDES@its.jnj.com		Date (Designer)	
PCC: AW_162415		Format Ref: S/B/3456-S3 45x29x135		1. 19-AUG-19 (Santosh)	
Tech. info/Spec: -		Country: USA		2. 26-AUG-19 (Santosh)	
Mat. ID Code: 99999A		File Name: AW_162415.ai (CS6-PC)		3. 28-AUG-19 (Santosh)	
		Black		4. 28-FEB-20 (Luis)	
		PMS 2607		5. 28-FEB-20 (Luis)	
		PMS 3242		6.	
		PMS 605		7.	
		Diecut (not to be printed)		8.	
		Varnish free			
		Varnish free & Used for glue			
		Perforation			



Box STELARA		Global Graphic Services		janssen	
PCC: AW_162418		Inge Vermeiren: Tel.: +32 (0)14606915 - E-mail: ivermei1@its.jnj.com Shared mailbox: RA-JANBE-GRAPHDES@its.jnj.com		Date (Designer)	
Format Ref:	S/B/3456-S3 45x29x135	Black	Diecut (not to be printed)	1.	19-AUG-19 (Santosh)
Tech. info/Spec:	-	PMS 2607	Varnish free	2.	26-AUG-19 (Santosh)
Country:	USA	PMS 3242	Varnish free & Used for glue	3.	28-AUG-19 (Santosh)
Mat. ID Code:	99999A	PMS 605	Perforation	4.	28-FEB-20 (Luis)
File Name:	AW_162418.ai (CS6-PC)	PMS 021		5.	
				6.	
				7.	
				8.	



Amy
Rosenberg



Digitally signed by Amy Rosenberg

Date: 3/19/2020 12:55:38PM

GUID: 508da6d9000264a593fe391fce272f33