

**HIGHLIGHTS OF PRESCRIBING INFORMATION**

These highlights do not include all the information needed to use BETHKIS safely and effectively. See full prescribing information for BETHKIS.

**BETHKIS® (Tobramycin Inhalation Solution)**  
Initial U.S. Approval: 1980

-----RECENT MAJOR CHANGES-----

Warnings and Precautions, Bronchospasm (5.4) 5/2017  
Warnings and Precautions, Laboratory Testing (5.5) 5/2017

-----INDICATIONS AND USAGE-----

BETHKIS is an inhaled aminoglycoside antibacterial indicated for the management of cystic fibrosis patients with *Pseudomonas aeruginosa*. (1) Safety and efficacy have not been demonstrated in patients under the age of six years, patients with a forced expiratory volume in one second (FEV<sub>1</sub>) less than 40% or greater than 80% predicted, or patients colonized with *Burkholderia cepacia*. (1)

-----DOSAGE AND ADMINISTRATION-----

Administer the entire contents of one ampule twice daily by oral inhalation in repeated cycles of 28 days on drug, followed by 28 days off drug. (2.1)

-----DOSAGE FORMS AND STRENGTHS-----

A clear, colorless to pale yellow solution for oral inhalation in a single-use ampule containing 300 mg tobramycin. (16)

-----CONTRAINDICATIONS-----

BETHKIS is contraindicated in patients with a known hypersensitivity to any aminoglycoside. (4)

-----WARNINGS AND PRECAUTIONS-----

- Caution should be exercised when prescribing BETHKIS to patients with known or suspected auditory, vestibular, renal, or neuromuscular dysfunction. (5.1, 5.2, 5.3 and 5.5)
- Aminoglycoside may aggravate muscle weakness because of a potential curare-like effect on neuromuscular function. (5.3)
- Bronchospasm can occur with inhalation of BETHKIS. (5.4)
- Audiograms, serum concentration, and renal function should be monitored as appropriate. (5.2 and 5.5)
- Fetal harm can occur when aminoglycosides are administered to a pregnant woman. Apprise women of the potential hazard to the fetus. (5.5)

-----ADVERSE REACTIONS-----

Common adverse reactions (more than 5%) occurring more frequently in BETHKIS patients are forced expiratory volume decreased, rales, red blood cell sedimentation rate increased, and dyspnoea. (6.1)

To report SUSPECTED ADVERSE REACTIONS, contact Chiesi USA, Inc. at 1-888-661-9260 or FDA at 1-800-FDA-1088 or [www.fda.gov/medwatch](http://www.fda.gov/medwatch).

-----DRUG INTERACTIONS-----

- Concurrent and/or sequential use of BETHKIS with other drugs with neurotoxic, nephrotoxic or ototoxic potential should be avoided. (7.1)
- BETHKIS should not be administered concomitantly with ethacrynic acid, furosemide, urea, or intravenous mannitol. (7.2)

-----USE IN SPECIFIC POPULATIONS-----

- Aminoglycosides can cause fetal harm when administered to a pregnant woman. (8.1)
- Nursing mothers: discontinue drug or nursing, taking into consideration the importance of the drug to a mother. (8.3)

See 17 for PATIENT COUNSELING INFORMATION and FDA-approved patient labeling.

Revised: 5/2017

**FULL PRESCRIBING INFORMATION: CONTENTS\***

<b>1</b>	<b>INDICATIONS AND USAGE</b>
<b>2</b>	<b>DOSAGE AND ADMINISTRATION</b>
2.1	Dosing Information
2.2	Administration
<b>3</b>	<b>DOSAGE FORMS AND STRENGTHS</b>
<b>4</b>	<b>CONTRAINDICATIONS</b>
<b>5</b>	<b>WARNINGS AND PRECAUTIONS</b>
5.1	Ototoxicity
5.2	Nephrotoxicity
5.3	Neuromuscular Disorders
5.4	Bronchospasm
5.5	Laboratory Tests
5.6	Use in Pregnancy
<b>6</b>	<b>ADVERSE REACTIONS</b>
6.1	Clinical Trials Experience
6.2	Postmarketing Experience
<b>7</b>	<b>DRUG INTERACTIONS</b>
7.1	Drugs with Neurotoxic, Nephrotoxic, or Ototoxic Potential
7.2	Ethacrynic Acid, Furosemide, Urea, or Mannitol
<b>8</b>	<b>USE IN SPECIFIC POPULATIONS</b>
8.1	Pregnancy
8.2	Labor and Delivery
8.3	Nursing Mothers
8.4	Pediatric Use
8.5	Geriatric Use
8.6	Renal Impairment

<b>10</b>	<b>OVERDOSAGE</b>
<b>11</b>	<b>DESCRIPTION</b>
<b>12</b>	<b>CLINICAL PHARMACOLOGY</b>
12.1	Mechanism of Action
12.3	Pharmacokinetics
12.4	Microbiology
<b>13</b>	<b>NONCLINICAL TOXICOLOGY</b>
13.1	Carcinogenesis, Mutagenesis, Impairment of Fertility
<b>14</b>	<b>CLINICAL STUDIES</b>
<b>15</b>	<b>REFERENCES</b>
<b>16</b>	<b>HOW SUPPLIED/STORAGE AND HANDLING</b>
<b>17</b>	<b>PATIENT COUNSELING INFORMATION</b>
17.1	Ototoxicity
17.2	Bronchospasm
17.3	Risks Associated with Aminoglycosides
17.4	Laboratory Tests
17.5	Pregnancy
17.6	Storage Instructions
17.7	Additional Information

\*Sections or subsections omitted from the Full Prescribing Information are not listed.

## FULL PRESCRIBING INFORMATION

### 1 INDICATIONS AND USAGE

BETHKIS is indicated for the management of cystic fibrosis patients with *Pseudomonas aeruginosa*. Safety and efficacy have not been demonstrated in patients under the age of six years, patients with FEV<sub>1</sub> less than 40% or greater than 80% predicted, or patients colonized with *Burkholderia cepacia* [see *Clinical Studies* (14)].

### 2 DOSAGE AND ADMINISTRATION

#### 2.1 Dosing Information

The recommended dosage for patients six years of age and older is to administer one single-use ampule (300 mg/4 mL) twice daily by oral inhalation in repeated cycles of 28 days on drug, followed by 28 days off drug. The doses should be taken as close to 12 hours apart as possible and not less than 6 hours apart.

The 300 mg/4 mL dose of BETHKIS is the same for patients regardless of age or weight. BETHKIS has not been studied in patients less than six years old.

#### 2.2 Administration

BETHKIS is administered by oral inhalation. Do not use by any other route.

BETHKIS is administered by inhalation using a hand-held PARI LC PLUS Reusable Nebulizer with a PARI Vios Air compressor over an approximately 15 minute period and until sputtering from the output of the nebulizer has occurred for at least one minute.

Further patient instructions on how to administer BETHKIS are provided in the *Patient's Instructions for Use* [see *Patient Counseling Information* (17)].

### 3 DOSAGE FORMS AND STRENGTHS

4 mL single-use ampules containing 300 mg of tobramycin.

### 4 CONTRAINDICATIONS

BETHKIS is contraindicated in patients with a known hypersensitivity to any aminoglycoside.

### 5 WARNINGS AND PRECAUTIONS

#### 5.1 Ototoxicity

Caution should be exercised when prescribing BETHKIS to patients with known or suspected auditory or vestibular dysfunction.

Findings related to ototoxicity as measured by audiometric evaluations and auditory adverse event reports were similar between BETHKIS and placebo in controlled clinical trials. Hearing loss was reported in two (1.1%) BETHKIS-treated patients and in one (0.9%) placebo-treated patient during clinical studies. Additionally, dizziness and vertigo, both of which may be manifestations of vestibular forms of ototoxicity, were observed in similar numbers of BETHKIS- and placebo-treated patients. Dizziness occurred in two (1.1%) BETHKIS-treated patients and one (0.9%) placebo-treated patient and vertigo occurred in two (1.1%) BETHKIS-treated patients versus no placebo patients in clinical studies. None of the BETHKIS patients discontinued their therapy due to hearing loss, dizziness or vertigo.

Tinnitus may be a sentinel symptom of ototoxicity. No reports of tinnitus occurred in patients during clinical studies with BETHKIS, but because it has been observed with inhaled tobramycin solutions [see *Adverse Reactions* (6.2)], onset of this symptom warrants caution. Ototoxicity, manifested as both auditory and vestibular toxicity, has been reported with parenteral aminoglycosides. Vestibular toxicity may be manifested by vertigo, ataxia or dizziness.

#### 5.2 Nephrotoxicity

Caution should be exercised when prescribing BETHKIS to patients with known or suspected renal dysfunction.

Nephrotoxicity was not seen during BETHKIS clinical studies but has been associated with aminoglycosides as a class. If nephrotoxicity occurs in a patient receiving BETHKIS, therapy should be discontinued until serum concentrations fall below 2 mcg/mL.

Twenty-six (14%) BETHKIS patients and 15 (13%) placebo patients had increases in serum creatinine of at least 50% over baseline. Follow-up values were obtained for 17 of the 26 BETHKIS patients, all of which decreased to serum creatinine values that were within normal laboratory ranges. Patients who experience an increase in serum creatinine during treatment with BETHKIS should have their renal function closely monitored.

#### 5.3 Neuromuscular Disorders

BETHKIS should be used cautiously in patients with muscular disorders, such as myasthenia gravis or Parkinson's disease, since aminoglycosides may aggravate muscle weakness because of a potential curare-like effect on neuromuscular function.

#### 5.4 Bronchospasm

Bronchospasm has been reported with inhalation of tobramycin. In clinical studies with BETHKIS, bronchospasm was observed in one (0.5%) BETHKIS-treated patient and in no placebo-treated patients. Wheezing occurred in ten (5%) BETHKIS-treated patients and four (4%) placebo-treated patients. Bronchospasm and wheezing should be treated as medically appropriate.

#### 5.5 Laboratory Tests

Audiograms

Clinical studies of inhaled tobramycin solutions did not identify hearing loss using audiometric tests which evaluated hearing up to 8000 Hz. Physicians should consider an audiogram for patients who show any evidence of auditory dysfunction, or who are at increased risk for auditory dysfunction. Tinnitus may be a sentinel symptom of ototoxicity, and therefore the onset of this symptom warrants caution.

Serum Concentrations

In patients with normal renal function treated with BETHKIS, serum tobramycin concentrations range from approximately 0.06-1.89 mcg/mL one hour after dose administration and do not require routine monitoring. Serum concentrations of tobramycin in patients with renal dysfunction or patients treated with concomitant parenteral tobramycin should be monitored at the discretion of the treating physician [see *Clinical Pharmacology (12.3)*].

The serum concentration of tobramycin should only be monitored through venipuncture and not finger prick blood sampling. Contamination of the skin of the fingers with tobramycin may lead to falsely increased measurements of serum levels of the drug. This contamination cannot be completely avoided by hand washing before testing.

Renal Function

The clinical studies of BETHKIS did not reveal any imbalance in the percentage of patients who experienced at least a 50% rise in serum creatinine from baseline in either the BETHKIS group (n=26, 14%) or the placebo group (n=15, 13%). Laboratory tests of urine and renal function should be conducted at the discretion of the treating physician.

**5.6 Use in Pregnancy**

Aminoglycosides can cause fetal harm when administered to a pregnant woman. Aminoglycosides cross the placenta, and streptomycin has been associated with several reports of total, irreversible, bilateral congenital deafness in pediatric patients exposed *in utero*. Patients who use BETHKIS during pregnancy, or become pregnant while taking BETHKIS should be apprised of the potential hazard to the fetus.

**6 ADVERSE REACTIONS**

**6.1 Clinical Trials Experience**

Because clinical trials are conducted under widely varying conditions, adverse reaction rates observed in clinical trials of drugs cannot be directly compared to rates in the clinical trials of another drug and may not reflect the rates observed in practice.

The data described below reflect exposure to BETHKIS in two placebo-controlled studies in 305 cystic fibrosis patients. Patients receiving BETHKIS ranged in age from 6 to 31 years.

In Study 1, an eight week study, 29 patients received BETHKIS versus 30 patients who received placebo for a total of four weeks on drug and four weeks off drug. All patients were ≤ 30 years of age (mean age 12.6 years) and 46% were females. 52.5% of patients were 6 to 12 years of age while 30.5% of patients were 13-17 years old. Only 16.5% of patients were adults (> 17 years old). Eighty percent (80%) of patients were chronically colonized with *Pseudomonas aeruginosa* while 20.3% of patients were initially or intermittently colonized with *Pseudomonas aeruginosa* during the study.

More patients in the placebo group discontinued/dropped out of Study 1 than in the BETHKIS group (23% [7/30] vs 3.4% [1/29], respectively). Five patients in the placebo group compared to none in the BETHKIS group discontinued/dropped out because of treatment-emergent adverse events (TEAEs) such as pulmonary exacerbations and respiratory disorders.

In Study 2, a 24 week study, 161 patients received BETHKIS versus 85 patients who received placebo in alternating four week on-off cycles for three cycles. All patients were ≤ 46 years of age (mean age 14.8 years) and 45% were females. 41% of patients were 6-12 years old while 29% of patients were 13-17 years old. Only 30% were adults (>17 years). Eighty-seven percent (87%) of patients were chronically colonized with *P. aeruginosa*. Only 13% were either initially or intermittently colonized with *P. aeruginosa* during the study.

More patients in the placebo group discontinued/dropped out of Study 2 than in the BETHKIS group (9.4% [8/85] vs 4.3% [7/161], respectively). Of these, 3 patients in the BETHKIS group (1.9%) compared to 2 patients in the placebo group (2.4%) withdrew due to a TEAE. The most common TEAEs causing patients to discontinue from the study drug are respiratory, thoracic, and mediastinal disorders.

The most common adverse experiences reported were respiratory disorders, consistent with the underlying disease in the patient population being evaluated and these were similarly distributed between both BETHKIS- and placebo-treated patients. The following adverse reactions were reported in at least 5% of Bethkis-treated patients and at rates ≥ 2% more common compared to the placebo-treated patients: decreased forced expiratory volume, rales, red blood cell sedimentation rate increased, and dysphonia (Table 1).

**Table 1: Patients with Selected Treatment-Emergent Adverse Reactions Occurring in ≥ 2% of BETHKIS Patients**

Adverse Reactions	BETHKIS N=190 (%)	Placebo N=115 (%)
Forced expiratory volume decreased	59 (31%)	33 (29%)
Rales	36 (19%)	18 (16%)
Red blood cell sedimentation rate increased	16 (8%)	6 (5%)
Dysphonia	11 (6%)	2 (2%)
Wheezing	10 (5%)	4 (4%)
Epistaxis	6 (3%)	0
Pharyngolaryngeal pain	5 (3%)	2 (2%)
Bronchitis	5 (3%)	1 (1%)

Tonsillitis	4 (2%)	0
Diarrhea	3 (2%)	1 (1%)
Eosinophilia	3 (2%)	0
Immunoglobulins increased	3 (2%)	0

## 6.2 Postmarketing Experience

The following adverse reactions have been identified during postapproval use of tobramycin inhalation solution. Because these reactions are reported voluntarily from a population of uncertain size, it is not always possible to reliably estimate their frequency or establish a causal relationship to drug exposure.

*Ear and labyrinth disorders:* Hearing loss, Tinnitus [see *Warnings and Precautions (5.1)*]

*Skin and subcutaneous tissue disorders:* Hypersensitivity, pruritus, urticaria, rash

*Nervous system disorders:* Aphonia, dysgeusia

*Respiratory, thoracic, and mediastinal disorders:* Bronchospasm [see *Warnings and Precautions (5.4)*], oropharyngeal pain

*Metabolism and Nutrition Disorders:* Decreased appetite

## 7 DRUG INTERACTIONS

### 7.1 Drugs with Neurotoxic, Nephrotoxic, or Ototoxic Potential

Concurrent and/or sequential use of BETHKIS with other drugs with neurotoxic, nephrotoxic, or ototoxic potential should be avoided.

### 7.2 Ethacrynic Acid, Furosemide, Urea, or Mannitol

Some diuretics can enhance aminoglycoside toxicity by altering antibiotic concentrations in serum and tissue. Therefore, BETHKIS should not be administered concomitantly with ethacrynic acid, furosemide, urea, or intravenous mannitol. The interaction between inhaled mannitol and BETHKIS has not been evaluated.

## 8 USE IN SPECIFIC POPULATIONS

### 8.1 Pregnancy

Teratogenic Effects-Pregnancy Category D

No reproduction toxicology studies have been conducted with inhaled tobramycin. However, subcutaneous administration of tobramycin at doses of 100 mg or 20 mg/kg/day during organogenesis was not teratogenic in rats or rabbits, respectively. Subcutaneous doses of tobramycin  $\geq$  40mg/kg/day were severely maternally toxic to rabbits and precluded the evaluation of teratogenicity. Aminoglycosides can cause fetal harm (e.g., congenital deafness) when administered to a pregnant woman. Ototoxicity was not evaluated in offspring during nonclinical reproduction toxicity studies with tobramycin. If tobramycin is used during pregnancy, or if the patient becomes pregnant while taking tobramycin, the patient should be apprised of the potential hazard to the fetus.

### 8.2 Labor and Delivery

The safety and efficacy of BETHKIS have not been studied in the puerperal patient.

### 8.3 Nursing Mothers

It is not known if tobramycin will reach sufficient concentrations after administration by inhalation to be excreted in human breast milk. Because of the potential for ototoxicity and nephrotoxicity in infants, a decision should be made whether to terminate nursing or discontinue tobramycin therapy, taking into account the importance of the drug to the mother.

### 8.4 Pediatric Use

The safety and efficacy of BETHKIS have not been studied in pediatric cystic fibrosis patients under six years of age.

### 8.5 Geriatric Use

Clinical studies of BETHKIS did not include patients aged 65 years and over. Tobramycin is known to be substantially excreted by the kidney, and the risk of adverse reactions to this drug may be greater in patients with impaired renal function. Because elderly patients are more likely to have decreased renal function, it may be useful to monitor renal function [see *Warnings and Precautions (5.2, 5.5)*].

### 8.6 Renal Impairment

Tobramycin is primarily excreted unchanged in the urine and renal function is expected to affect the exposure of tobramycin. The risk of adverse reactions to this drug may be greater in patients with impaired renal function. Patients with serum creatinine  $>$  2mg/dL and blood urea nitrogen (BUN)  $>$  40mg/dL have not been included in clinical studies and there are no data in this population to support a recommendation for or against dose adjustment [see *Warnings and Precautions (5.2, 5.5)*].

Serum concentrations of tobramycin in patients with renal dysfunction, or patients treated with concomitant parenteral tobramycin should be monitored at the discretion of the treating physician.

## 10 OVERDOSAGE

No overdoses have been reported with BETHKIS in clinical trials. Signs and symptoms of acute toxicity from overdosage of intravenous tobramycin might include dizziness, tinnitus, vertigo, loss of high-tone hearing acuity, respiratory failure, neuromuscular blockade, and renal impairment. Administration by inhalation results in low systemic bioavailability of tobramycin. Tobramycin is not significantly absorbed following oral administration. Tobramycin serum concentrations may be helpful in monitoring overdosage.

In all cases of suspected overdosage, physicians should contact the Regional Poison Control Center for information about effective treatment. In the case of any overdosage, the possibility of drug interactions with alterations in drug disposition should be considered.

## 11 DESCRIPTION

BETHKIS is a sterile, clear, colorless to pale yellow, non-pyrogenic, aqueous solution with pH and salinity adjusted. BETHKIS is administered by a compressed air driven reusable nebulizer. The chemical formula for tobramycin is  $C_{18}H_{37}N_5O_9$  and the molecular weight is 467.52. Tobramycin is O-3-amino-3-deoxy- $\alpha$ -D-glucopyranosyl-(1 $\rightarrow$ 4)-O-[2,6-diamino-2,3,6-trideoxy- $\alpha$ -D-ribo-hexopyranosyl-(1 $\rightarrow$ 6)]-2-deoxy-L-streptomine.

The structural formula for tobramycin is:

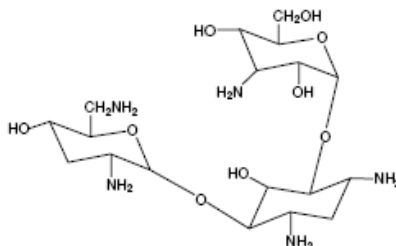

Each single-use 4 mL ampule of BETHKIS contains one 300 mg dose of tobramycin, with sodium chloride and sulfuric acid in water for injection. Sulfuric acid and sodium hydroxide are used to adjust the pH, as needed, to 5.0. Nitrogen is used for sparging, filling and pouching. The formulation contains no preservatives.

## 12 CLINICAL PHARMACOLOGY

### 12.1 Mechanism of Action

BETHKIS is an antibacterial drug [see *Clinical Pharmacology* (12.4)].

### 12.3 Pharmacokinetics

BETHKIS contains tobramycin, a cationic polar molecule that does not readily cross epithelial membranes.<sup>1</sup> The bioavailability of BETHKIS may vary because of individual differences in nebulizer performance and airway pathology.<sup>2</sup> Following administration of BETHKIS, tobramycin remains concentrated primarily in the airways.

*Sputum Concentrations:* Thirty minutes after inhalation of the first 300 mg dose of BETHKIS, the maximum geometric mean concentration of tobramycin was 814 mcg/g (ranging from 23 to 2843 mcg/g) in sputum. High variability of tobramycin concentration in sputum was observed. Three hours after inhalation started, sputum tobramycin concentrations declined to approximately 15% of those observed at 30 minutes. After four weeks of therapy with BETHKIS average mean sputum tobramycin concentrations obtained 10 minutes following administration were 717 mcg/g.

*Elimination:* The elimination half-life of tobramycin from serum is approximately two hours after intravenous (IV) administration. The elimination half-life following the inhalation of BETHKIS is approximately 4.4 hours. Assuming tobramycin absorbed following inhalation behaves similarly to tobramycin following intravenous administration, systemically absorbed tobramycin is eliminated principally by glomerular filtration. Unabsorbed tobramycin following inhalation is likely eliminated in expectorated sputum.

### 12.4 Microbiology

#### Mechanism of Action

Tobramycin, an aminoglycoside antimicrobial, acts primarily by disrupting protein synthesis in the bacterial cell which eventually leads to death of the cell. Tobramycin has activity against a wide range of gram-negative bacteria including *P. aeruginosa*. It is bactericidal at or above the minimal inhibitory concentration (MIC) needed to inhibit growth of bacteria.

#### Mechanism of Resistance

The predominant mechanism of resistance to tobramycin in *P. aeruginosa* isolated from CF patients is impermeability and to a lesser extent enzymatic modification and other mechanisms which cumulatively lead to decreased susceptibility of *P. aeruginosa* to tobramycin.

#### Cross Resistance

Cross resistance between aminoglycosides exists but the cross resistance is variable.

#### Development of Resistance

Treatment for six months with BETHKIS in one clinical trial did not affect the susceptibility of the majority of *P. aeruginosa* isolates tested; however, increases in minimal inhibitory concentrations (MIC) were noted in some patients. The clinical significance of this information has not been clearly established in the treatment of cystic fibrosis patients.

#### Susceptibility Testing

The clinical microbiology laboratory should provide cumulative results of the *in vitro* susceptibility test results for antimicrobial drugs used in local hospitals and practice areas to the physicians as periodic reports that describe the susceptibility profile of nosocomial and community-acquired pathogens. These reports should aid the physician in selecting the most effective antimicrobial.

## Susceptibility Testing Techniques

### Dilution Techniques

Quantitative methods can be used to determine the minimum inhibitory concentration (MIC) of tobramycin that will inhibit the growth of the bacteria being tested. The MIC provides an estimate of the susceptibility of bacteria to tobramycin. The MIC should be determined using a standardized procedure.<sup>3,5</sup> Standardized procedures are based on a dilution method (broth or agar) or equivalent with standardized inoculum concentrations and standardized concentrations of tobramycin powder.

### Diffusion Techniques

Quantitative methods that require measurement of zone diameters also provide reproducible estimates of the susceptibility of bacteria to antimicrobial compounds. One such standardized procedure requires the use of standardized inoculum concentrations.<sup>4,5</sup> This procedure uses paper disks impregnated with 10 mcg of tobramycin to test the susceptibility of bacteria to tobramycin.

### Susceptibility Test Interpretive Criteria

*In vitro* susceptibility test interpretive criteria for inhaled tobramycin have not been determined. The relation of the *in vitro* MIC and/or disk diffusion susceptibility test results to clinical efficacy of inhaled tobramycin against the bacteria tested should be monitored.

### Quality Control Parameters for Susceptibility Testing

*In vitro* susceptibility test quality control parameters exist for tobramycin so that laboratories that test the susceptibility of bacterial isolates to tobramycin can determine if the susceptibility test is performing correctly. Standardized dilution techniques and diffusion methods require the use of laboratory control bacteria to monitor the technical aspects of the laboratory procedures. Standard tobramycin powder should provide the following MIC and a 10 mcg tobramycin disk should produce the following zone diameters with the indicated quality control strains (Table 2).

Table 2: Acceptable Quality Control Ranges for Tobramycin

Bacteria	MIC Range (mcg/mL)	Disk Diffusion Zone Diameter (mm)
<i>Pseudomonas aeruginosa</i> ATCC 27853	0.25-1	19-25

### Other

No trends in the treatment-emergent isolation of other bacterial respiratory pathogens such as *Burkholderia cepacia*, *Stenotrophomonas maltophilia*, *Achromobacter xylosoxidans*, or *Staphylococcus aureus* were observed in clinical trials of BETHKIS relative to placebo. There was a slight increase in isolation of *Candida spp* in sputum at the end of the BETHKIS treatment cycle in clinical trials.

## 13 NONCLINICAL TOXICOLOGY

### 13.1 Carcinogenesis, Mutagenesis, Impairment of Fertility

A two-year rat inhalation toxicology study to assess carcinogenic potential of an inhaled solution of tobramycin has been completed. Rats were exposed to tobramycin for up to 1.5 hours per day for 95 weeks. Serum levels of tobramycin up to 35 mcg/mL were measured in rats, 35x the average 1 mcg/mL exposure levels observed in cystic fibrosis patients in clinical trials. There was no drug-related increase in the incidence of any variety of tumors.

Additionally, tobramycin has been evaluated for genotoxicity in a battery of *in vitro* and *in vivo* tests. The Ames bacterial reversion test, conducted with five tester strains, failed to show a significant increase in revertants with or without metabolic activation in all strains. Tobramycin was negative in the mouse lymphoma forward mutation assay, did not induce chromosomal aberrations in Chinese hamster ovary cells, and was negative in the mouse micronucleus test.

Subcutaneous administration of up to 100 mg/kg of tobramycin did not affect mating behavior or cause impairment of fertility in male or female rats.

## 14 CLINICAL STUDIES

Two, double-blind, randomized, placebo-controlled, parallel group clinical studies (Study 1 and Study 2), which randomized and dosed 306 patients, were conducted in cystic fibrosis patients with *P. aeruginosa*. The osmolality of the drug formulation used in these studies differed from the to-be-marketed product. To rely upon the efficacy and safety established in the placebo-controlled studies, an additional study was conducted as a bridge to the to-be-marketed drug. The bridging study assessed the efficacy and tolerability of aerosolized Tobramycin Inhalation Solution with osmolality similar to BETHKIS over a 4-week treatment in 324 patients with cystic fibrosis. Results of this study showed that the Tobramycin Inhalation Solution in this study had similar efficacy as that seen in the placebo-controlled studies.

The compressors in the placebo-controlled studies and the bridging study differed from the PARI VIOS compressor to be used with BETHKIS. *In vitro* cascade impaction studies demonstrated that the various compressors used in the clinical trials delivered equivalent doses and respirable fractions of the to-be-marketed BETHKIS and TOBI with the marketed compressor (PARI VIOS) when used with the same nebulizer (PARI LC Plus Reusable nebulizer).

All subjects enrolled in both efficacy studies had baseline FEV<sub>1</sub> % predicted  $\geq 40\%$  and  $\leq 80\%$  (mean baseline FEV<sub>1</sub> of 60% of predicted normal) and infected with *P. aeruginosa*. Subjects who were less than 6 years of age, or who had a baseline creatinine of  $\geq 1.5$  mg/dL, or who had *Burkholderia cepacia* isolated from sputum were excluded. A total of 190 patients, 29 in Study 1 and 161 in Study 2, received BETHKIS therapy on an outpatient basis. Of these, 55% were males and 45% were females. Eighty-two (43.2%) patients were between 6 and 12 years of age, 54 (28.4%) patients were between 13 and 17 years of age, and the remaining 54 (28.4%) patients were greater than 17 years of age. Of the patients who received BETHKIS, only 89.7% of patients in Study 1 had at least one concomitant medication, while all patients in Study 2 also received at

least one concomitant medication. These concomitant medications include mucolytics, steroidal and nonsteroidal anti-inflammatory drugs, bronchodilators, rehabilitative physiotherapies and if necessary, antibiotics for bacterial infections other than *P. aeruginosa*.

### Study 1

Study 1 was a double-blind, single cycle study that randomized 59 patients to receive BETHKIS (n=29) or placebo (n=30) for one cycle of treatment (28 days on treatment followed by 28 days off treatment). All patients were  $\leq 30$  years of age (mean age 12.6 years) and 46% were females. All randomized patients were included in the primary analysis except for one patient who had missing baseline information.

BETHKIS significantly improved lung function compared with placebo as measured by the absolute change in FEV<sub>1</sub> % predicted from baseline to the end of Cycle 1 dosing in the primary analysis population. Treatment with BETHKIS and placebo resulted in absolute increases in FEV<sub>1</sub> % predicted of 16% and 5%, respectively (LS mean difference = 11%; 95% CI: 3, 19; p=0.003). This analysis is adjusted for the covariate of baseline FEV<sub>1</sub> % predicted, using multiple imputation for missing data. Figure 1 shows the average change in FEV<sub>1</sub> % predicted over eight weeks.

### Study 2

Study 2 was a randomized, double-blind, 3-cycle, placebo-controlled trial. A total of 247 eligible patients were randomized 2:1 to receive three cycles of BETHKIS (n=161) or placebo (n=86). As in Study 1, each cycle comprised 28 days on treatment followed by 28 days off treatment. All patients were  $\leq 46$  years of age (mean age 14.8 years) and 44.9% were females. In this study, two randomized patients in the placebo group were not included in the primary efficacy analysis; one withdrew consent without taking any trial medication and the other withdrew due to an adverse drug reaction.

BETHKIS significantly improved lung function compared with placebo as measured by the absolute change in FEV<sub>1</sub> % predicted from baseline to the end of Cycle 3 "ON" period. Treatment with BETHKIS and placebo resulted in absolute increases in FEV<sub>1</sub> % predicted of 7% and 1%, respectively (LS mean difference = 6%; 95% CI: 3, 10; p<0.001). This analysis is adjusted for the covariate of baseline FEV<sub>1</sub> % predicted, using multiple imputation for missing data. Figure 1 shows the average change in FEV<sub>1</sub> % predicted over 24 weeks from Study 2.

**Figure 1: FEV<sub>1</sub>% of Predicted Normal – Absolute Change from Baseline (Adjusted mean) – ITT Population**



In Study 2, 9.9% of patients treated with BETHKIS and 24.7% of patients who received placebo had unplanned hospitalizations due to the disease.

Also in Study 2, 6.2% of patients treated with BETHKIS and 16.5% of placebo patients received parenteral tobramycin.

## 15 REFERENCES

1. Neu HC. Tobramycin: an overview. [Review]. J Infect Dis. 1976;Suppl 134:S3-19.
2. Weber A, Smith A, Williams-Warren J, et al. Nebulizer delivery of tobramycin to the lower respiratory tract. Pediatr Pulmonol. 1994;17(5):331-9.
3. Clinical and laboratory Standards Institute (CLSI) Methods for Dilution Antimicrobial Susceptibility Tests for Bacteria that Grow Aerobically: Approved Standard -9<sup>th</sup> edition. CLSI document M07-A9. CLSI 940 West Valley Rd. Suite 1400, Wayne PA 19087-1898. 2012
4. CLSI Performance Standards for Antimicrobial Susceptibility Testing: 22<sup>nd</sup> Informational supplement CLSI document M100-S22. CLSI 2012.
5. CLSI Performance standards for Antimicrobial Disk Susceptibility Tests: Approved standard -11<sup>th</sup> ed. CLSI document M02-A11. CLSI 2012.
6. PARI Vios Aerosol Delivery System with LC Plus Nebulizer: Instructions for Use. PARI Respiratory Equipment, Inc. 2010; 310D0028 Rev A 6-10.

## 16 HOW SUPPLIED/STORAGE AND HANDLING

BETHKIS 300 mg/4 mL is a clear, colorless to pale yellow solution and is available as follows:

- NDC 10122-820-56: 4 mL single-use ampule (carton of 14 foil pouches each containing four ampules)
- NDC 10122-820-28: 4 mL single-use ampule (carton of 7 foil pouches each containing four ampules)

**Storage**

BETHKIS should be stored under refrigeration at 36-46 °F/2-8 °C. Upon removal from the refrigerator, or if refrigeration is unavailable, BETHKIS pouches (opened or unopened) may be stored at room temperature (up to 77 °F/25 °C) for up to 28 days. BETHKIS should not be used beyond the expiration date stamped on the ampule when stored under refrigeration (36-46 °F/2-8 °C) or beyond 28 days when stored at room temperature (77 °F/25 °C).

BETHKIS ampules should not be exposed to intense light. BETHKIS is light sensitive; unopened ampules should be returned to the foil pouch. The solution in the ampule is colorless to pale yellow, but may darken with age if not stored in the refrigerator; however, the color change does not indicate any change in the quality of the product as long as it is stored within the recommended storage conditions.

**17 PATIENT COUNSELING INFORMATION**

Advise the patient to read the FDA-approved patient labeling (Patient Information and Instructions for Use).

**Information for Patients**

Information on the long term efficacy and safety of BETHKIS is limited. There is no information in patients with severe cystic fibrosis (FEV<sub>1</sub> < 40% predicted).

Patients should be advised to complete a full 28-day course of BETHKIS, even if they are feeling better. After 28 days of therapy, patients should stop BETHKIS therapy for the next 28 days, and then resume therapy for the next 28 day on and 28 day off cycle.

For patients taking several different inhaled medications and/or performing chest physiotherapy, advise the patient regarding the order they should take the therapies. It is recommended that BETHKIS be taken last.

BETHKIS is to be used with the PARI LC PLUS reusable nebulizer and the PARI VIOS air compressor. Refer to the manufacturer's instructions for care and use of the nebulizer and compressor.

**17.1 Ototoxicity**

Inform patients that ototoxicity, as measured by complaints of hearing loss or tinnitus, was reported by patients treated with tobramycin. Physicians should consider an audiogram at baseline, particularly for patients at increased risk of auditory dysfunction.

If a patient reports tinnitus or hearing loss during BETHKIS therapy, the physician should refer that patient for audiological assessment.

Patients should be reminded that vestibular toxicity may manifest as vertigo, ataxia, or dizziness.

**17.2 Bronchospasm**

Inform patients that bronchospasm can occur with inhalation of tobramycin.

**17.3 Risks Associated with Aminoglycosides**

Inform patients of adverse reactions associated with aminoglycosides such as nephrotoxicity and neuromuscular disorders.

**17.4 Laboratory Tests**

Inform patients of the need to monitor hearing, serum concentrations of tobramycin, or renal function as necessary during treatment with BETHKIS.

**17.5 Pregnancy**

Inform patients that aminoglycosides can cause fetal harm when administered to a pregnant woman. Advise them to inform their doctor if they are pregnant, become pregnant, or plan to become pregnant.

**17.6 Storage Instructions**

You should store BETHKIS ampules in a refrigerator (36-46 °F or 2-8 °C). However, when you don't have a refrigerator available (e.g., transporting your BETHKIS), you may store the foil pouches (opened or unopened) at room temperature (up to 77 °F/25 °C) for up to 28 days.

BETHKIS is light sensitive; unopened ampules should be returned to the foil pouch. Avoid exposing BETHKIS ampules to intense light. Unrefrigerated BETHKIS, which is normally colorless to pale yellow, may darken with age; however, the color change does not indicate any change in the quality of the product.

You should not use BETHKIS if it is cloudy, if there are particles in the solution, or if it has been stored at room temperature for more than 28 days. You should not use BETHKIS beyond the expiration date stamped on the ampule.

**17.7 Additional Information**

Nebulizers and Compressors: 1-800-327-8632

BETHKIS: 1-888-661-9260

**R** Only

U.S. Patent 6,987,094.

Manufactured for Chiesi USA, Inc.  
by Catalent Pharma Solutions, LLC  
Woodstock, Illinois 60098



This label may not be the latest approved by FDA.  
For current labeling information, please visit <https://www.fda.gov/drugsatfda>

© Chiesi USA, Inc. 2017  
Printed in USA  
CTB-004-0416-04A-W

## Patient Information

**BETHKIS<sup>®</sup>**

**(BETH kiss)**

**(tobramycin inhalation solution)**

Read this Patient Information before you start taking BETHKIS and each time you get a refill. There may be new information. This information does not take the place of talking with your healthcare provider about your medical condition or your treatment.

### What is BETHKIS?

BETHKIS is a prescription medicine used to treat people with cystic fibrosis who have a bacterial infection called *Pseudomonas aeruginosa*. BETHKIS contains an antibacterial medicine called tobramycin (an aminoglycoside).

It is not known if BETHKIS is safe and effective:

- in children under 6 years of age
- in people who have decreased lung volume or an FEV<sub>1</sub> less than 40% of predicted
- in people who are colonized with a bacterium called *Burkholderia cepacia*
- when used for more than 3 cycles

### Who should not take BETHKIS?

Do not take BETHKIS if you are allergic to tobramycin, any of the ingredients in BETHKIS, or to any other aminoglycoside antibacterial.

### What should I tell my healthcare provider before taking BETHKIS?

#### Before you take BETHKIS, tell your healthcare provider if you:

- have or have had hearing problems (including noises in your ears)
- have dizziness
- have or have had kidney problems
- have or have had problems with muscle weakness such as myasthenia gravis or Parkinson's disease
- have or have had breathing problems such as wheezing, coughing, or chest tightness
- have had an organ transplant
- are pregnant or plan to become pregnant.
- are breastfeeding or plan to breastfeed. It is not known if BETHKIS passes into your breast milk.

**Tell your healthcare provider about all the medicines you take**, including prescription and non-prescription medicines, vitamins, and herbal supplements.

Taking BETHKIS with certain other medicines can cause serious side effects.

If you are taking BETHKIS, you should discuss with your healthcare provider if you should take:

- other medicines that may harm your nervous system, kidneys, or hearing
- “water pills” (diuretics) such as Edecrin (ethacrynic acid), Lasix (furosemide), or intravenous mannitol
- urea

Ask your healthcare provider or pharmacist for a list of these medicines, if you are not sure.

Know the medicines you take. Keep a list of them and show it to your healthcare provider and pharmacist when you get a new medicine.

### **How should I take BETHKIS?**

- See the step-by-step Instructions for Use at the end of this Patient Information leaflet about the right way to take BETHKIS.
- Take BETHKIS exactly as your healthcare provider tells you to. Ask your healthcare provider or pharmacist if you are not sure.
- The usual dose of BETHKIS for adults and children over 6 years of age is:
  - 1 ampule of BETHKIS inhaled by mouth in the morning and 1 ampule of BETHKIS inhaled by mouth in the evening using your hand-held PARI LC PLUS Reusable Nebulizer with a PARI Vios air compressor.
- Each dose of BETHKIS should take about 15 minutes to finish.
- Each dose of BETHKIS should be taken as close to 12 hours apart as possible.
- You should not take your dose of BETHKIS less than 6 hours apart.
- After taking BETHKIS for 28 days, you should stop taking it and wait 28 days. After you have stopped taking BETHKIS for 28 days, you should start taking BETHKIS again for 28 days. It is important that you keep to the 28-day on, 28-day off cycle.
- Do not mix BETHKIS with dornase alfa (Pulmozyme) in your nebulizer.
- If you are taking other medicines inhaled through your mouth (bronchodilators), you should take them before you take BETHKIS.
- If you take too much BETHKIS, tell your healthcare provider right away.

### **What are the possible side effects of BETHKIS?**

#### **BETHKIS can cause serious side effects, including:**

- hearing loss or ringing in the ears (ototoxicity). Tell your healthcare provider right away if you have hearing loss or hear noises in your ears (such as ringing or hissing), or if you develop vertigo, dizziness, or difficulty with balance
- worsening kidney problems (nephrotoxicity). Your healthcare provider may do a blood test and urine test to check how your kidneys are working while you are taking BETHKIS.
- worsening muscle weakness. BETHKIS can cause muscle weakness to get worse in people who already have problems with muscle weakness (myasthenia gravis or Parkinson's disease).
- Tobramycin is in a class of drugs which may cause harm to an unborn baby.
- severe breathing problems (bronchospasm). Tell your healthcare provider right away if you get any of these symptoms of bronchospasm while taking BETHKIS:
  - shortness of breath with wheezing
  - coughing and chest tightness

#### **The most common side effects of BETHKIS include:**

- worsening of lung problems or cystic fibrosis
- noisy breathing (rales)
- abnormal red blood cell activity

- changes in your voice (hoarseness)

Tell your healthcare provider about any side effect that bothers you or that does not go away.

These are not all of the possible side effects of BETHKIS. For more information, ask your healthcare provider or pharmacist.

Call your doctor for medical advice about side effects. You may report side effects to FDA at 1-800-FDA-1088.

**General information about the safe and effective use of BETHKIS.**

Medicines are sometimes prescribed for purposes other than those listed in a patient information leaflet. Do not use BETHKIS for a condition for which it was not prescribed. Do not give BETHKIS to other people, even if they have the same symptoms that you have. It may harm them.

This leaflet summarizes the most important information about BETHKIS. If you would like more information, talk with your healthcare provider. You can ask your healthcare provider or pharmacist for information about BETHKIS that is written for health professionals.

For more information, call 1-888-661-9260.

**What are the ingredients in BETHKIS?**

**Active ingredient:** tobramycin

**Inactive ingredients:** sodium chloride, sulfuric acid, and sodium hydroxide (for pH adjustment)

## Instructions for Use

**BETHKIS®**

**(BETH kiss)**

**(tobramycin inhalation solution)**

Follow the instructions below for taking BETHKIS. If you have any questions, ask your healthcare provider or pharmacist.

BETHKIS is available as a 28-day supply containing 56 ampules including 14 foil pouches and as a 14-day supply containing 28 ampules including 7 foil pouches. Each foil pouch contains 4 BETHKIS ampules.

Supplies you will need to take BETHKIS (See Figure A):

- 1 ampule of BETHKIS
- PARI LC PLUS reusable nebulizer
- PARI Vios compressor
- tubing to connect the nebulizer and compressor
- clean paper or cloth towels
- nose clips (optional)

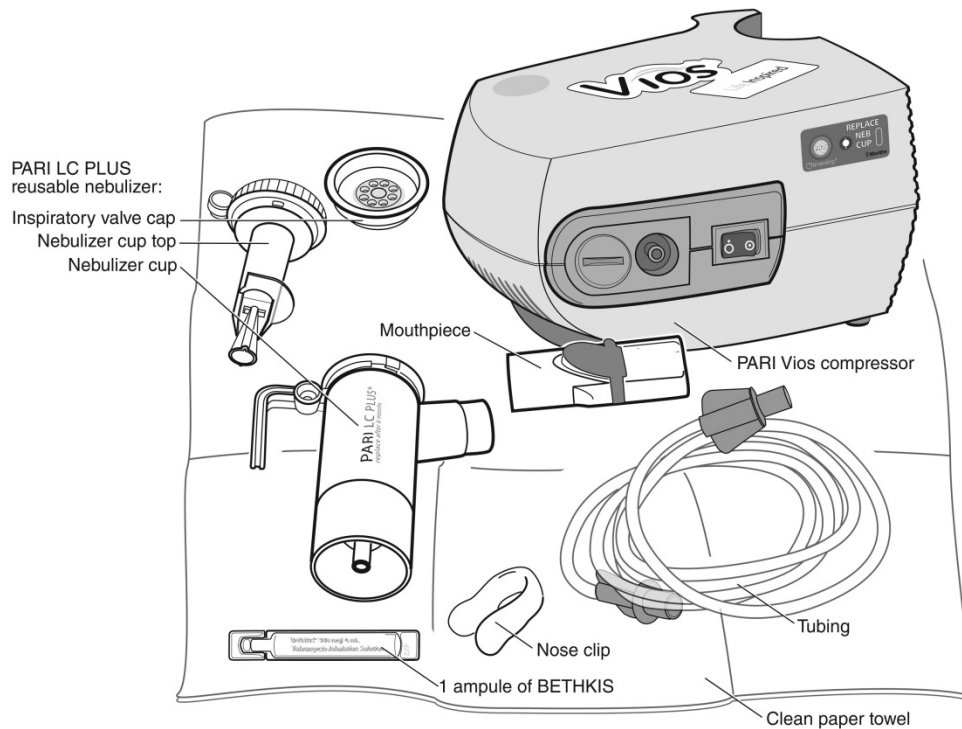

(Figure A)

**BETHKIS is used only in a PARI LC PLUS re-usable Nebulizer connected to a PARI LC PLUS Vios air compressor. Make sure you know how to use your nebulizer machine before you use it to breathe in BETHKIS.**

**Do not mix BETHKIS with other medicines in your nebulizer.**

BETHKIS comes in a sealed foil pouch. Do not open a sealed pouch until you are ready to use a dose of BETHKIS. After opening the pouch, unused ready-to-use ampoules should be returned to, and stored in, the pouch.

**Getting ready:**

- Put your PARI LC PLUS Reusable Nebulizer Top and Bottom (Nebulizer Cup) Assembly, Inspiratory Valve Cap, Mouthpiece with Valve, and Tubing on a clean and dry surface.
- Wash your hands with soap and water.

**Preparing your BETHKIS dose:**

**Step 1:** Open foil pouch. (See Figure B)

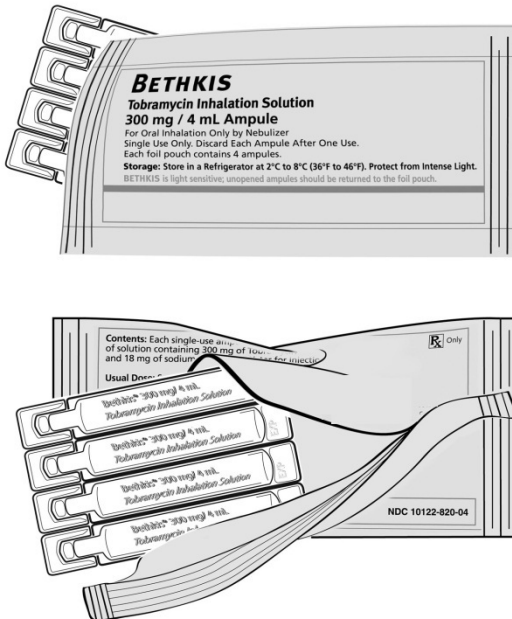

(Figure B)

**Step 2:** Separate 1 ampule by gently pulling apart at the bottom tabs (See Figure C) and use it right away.

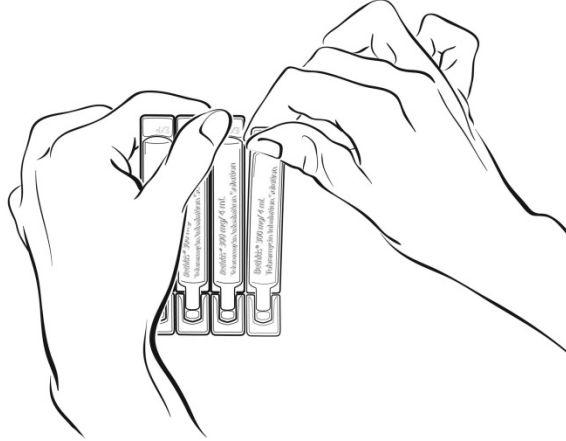

(Figure C)

**Step 3:** Hold the bottom tab on the BETHKIS ampule with 1 hand (See Figure D). With your other hand, hold the top of the ampule and twist off the top of the ampule (See Figure D).

- Do not squeeze the ampule until you are ready to squeeze all the medicine into the Nebulizer Cup.

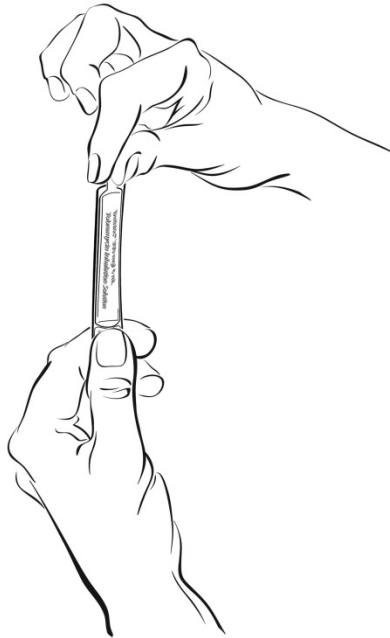

(Figure D)

**Step 4:** Hold the Nebulizer Cup and twist off the Nebulizer Cup Top in a counter-clockwise direction (See Figure E). Set the Top aside on a clean, dry surface.

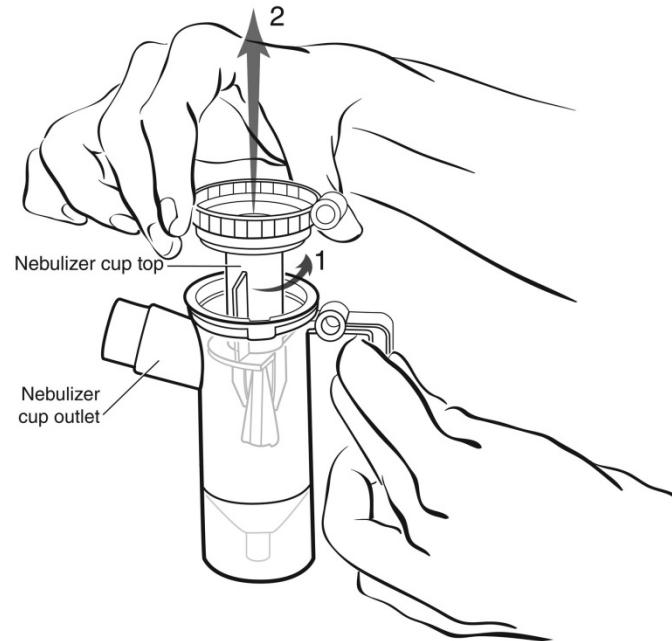

(Figure E)

**Step 5:** Squeeze all of the medicine from the ampule into the Nebulizer Cup (See Figure F).



(Figure F)

**Step 6:** Line up the semi-circle on the Nebulizer Cup Top with the Nebulizer Cup Outlet and twist on the Nebulizer Cup Top in a clock-wise direction until it is tight. (See Figure G).

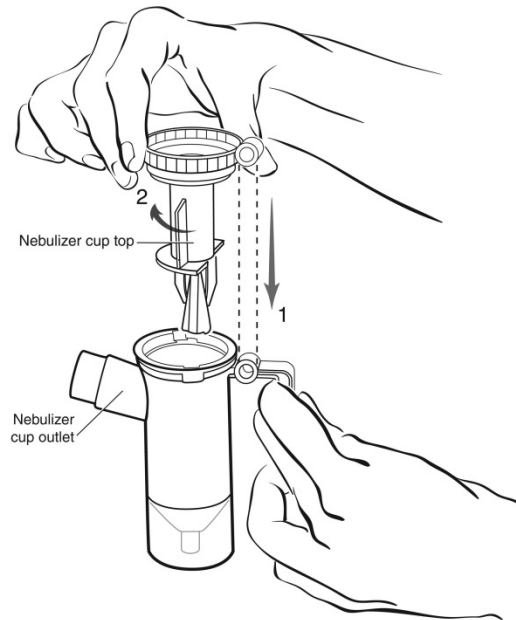

(Figure G)

**Step 7:** Push the mouthpiece straight onto the Nebulizer Cup Outlet (See Figure H).

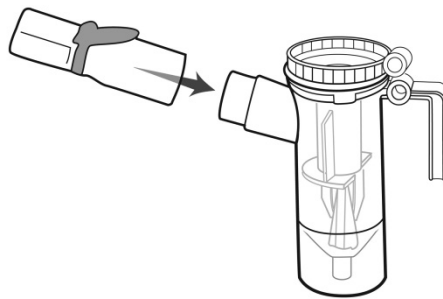

(Figure H)

- Step 8:** Firmly push the Inspiratory Valve Cap straight down onto the Nebulizer Cup Top (See Figure I). The Inspiratory Valve Cap should fit tightly.

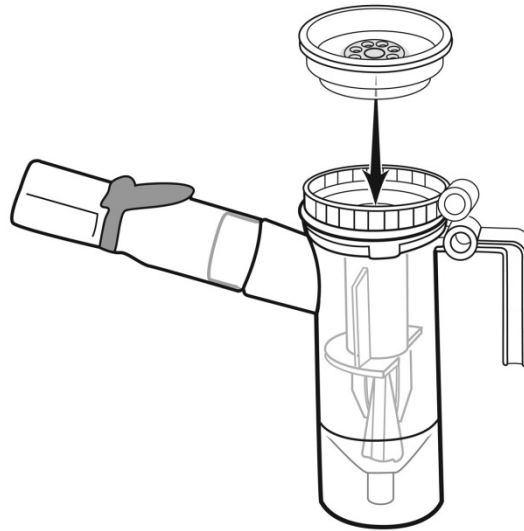

(Figure I)

- Step 9:** Connect 1 end of the tubing to the compressor air outlet. The tubing should fit tightly (See Figure J).



(Figure J)

**Step 10:** Plug your compressor plug into an electrical outlet (See Figure K).

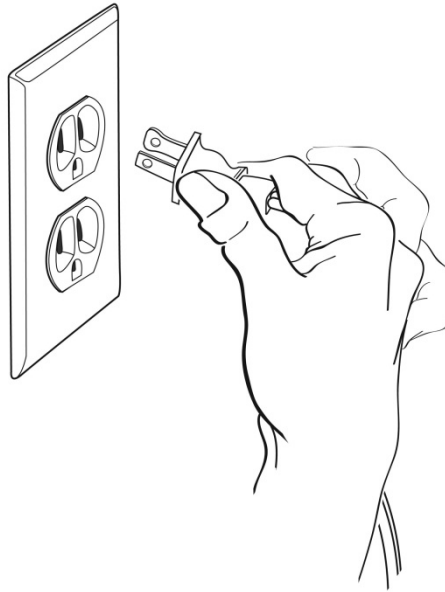

(Figure K)

**Step 11:** Hold the Nebulizer Cup upright and firmly push the free end of the tubing straight up onto the Air Intake on the bottom of the Nebulizer Cup (See Figure L). **Make sure to keep the Nebulizer Cup upright.**

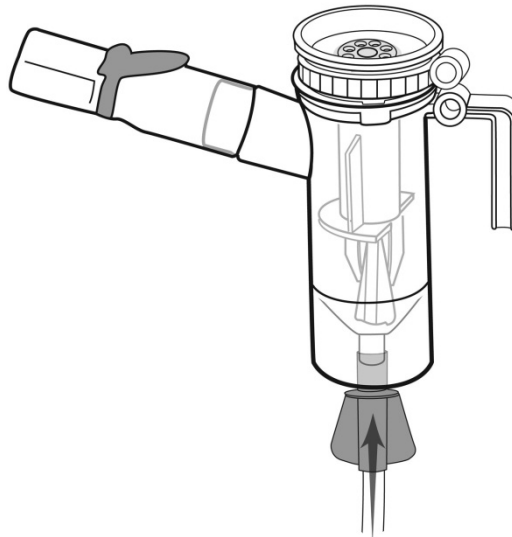

(Figure L)

**Giving your BETHKIS dose:**

**Step 12:** Turn on the compressor (Figure M) and check the Mouthpiece. You should see a steady mist coming from the Mouthpiece (Figure N).

- If you do not see a steady mist coming from the mouthpiece, check all tubing connections and make sure that the compressor is working the right way.



(Figure M)

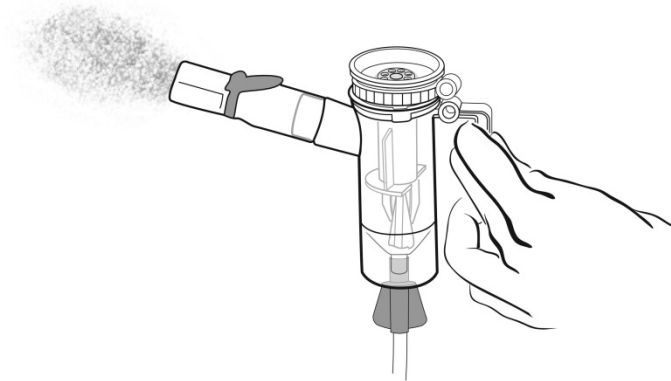

(Figure N)

- Step 13:** Sit or stand in a comfortable, upright position that will let you breathe normally. Place the Mouthpiece between your teeth and on top of your tongue and breathe normally only through your mouth (See Figure O).
- Nose clips may help you breathe only through your mouth and not through your nose.

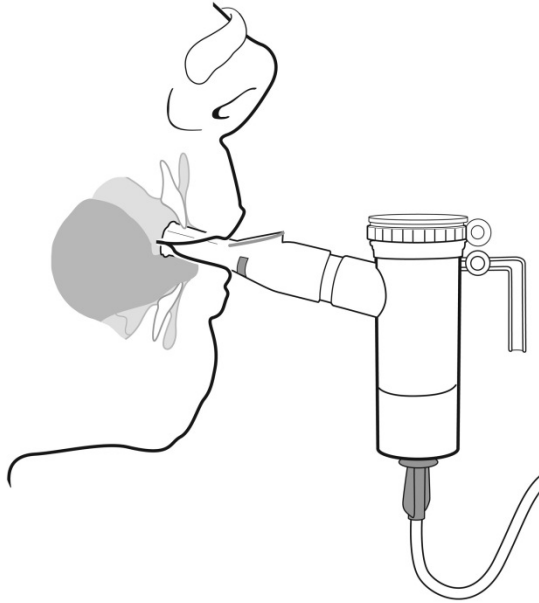

(Figure O)

- Step 14:** Keep breathing in your BETHKIS dose for at least 15 minutes. You will know that you have received your full dose of medicine when you hear a “spitting noise” coming from the Mouthpiece for at least 1 minute and the Nebulizer Cup is empty.

**After your BETHKIS Dose:**

- Step 15:** Clean and disinfect your nebulizer (see manufacturer’s instructions).

**Care and Use of Your PARI Vios® Compressor**

**Follow the manufacturer’s instructions for care and use of your compressor.**

**How should I store BETHKIS?**

- Store BETHKIS in the refrigerator at 36°F to 46°F (2°C to 8°C) until needed.
- BETHKIS may be stored at room temperature between 66°F to 77°F (20°C to 25°C) for up to 28 days.
- Do not use BETHKIS after the expiration date printed on the ampule.
- Keep BETHKIS ampules in the foil pouch and away from light.
- Keep BETHKIS and all medications out of the reach of children.

This label may not be the latest approved by FDA.  
For current labeling information, please visit <https://www.fda.gov/drugsatfda>

This Patient Information and Instructions for Use have been approved by the U.S. Food and Drug Administration.

Manufactured for Chiesi USA, Inc.  
by Catalent Pharma Solutions, LLC  
Woodstock, Illinois 60098



All trademarks referenced herein are the property of their prospective owners.

Issued: 5/2017

CTB-006-0416-03A-W