

HIGHLIGHTS OF PRESCRIBING INFORMATION

These highlights do not include all the information needed to use SIGNIFOR LAR safely and effectively. See full prescribing information for SIGNIFOR LAR.

SIGNIFOR® LAR (pasireotide) for injectable suspension, for intramuscular use

Initial U.S. Approval: 2012

INDICATIONS AND USAGE

SIGNIFOR LAR is a somatostatin analog indicated for the treatment of patients with acromegaly who have had an inadequate response to surgery and/or for whom surgery is not an option. (1.1)

DOSAGE AND ADMINISTRATION

- The initial dose is 40 mg by intramuscular injection once every 4 weeks (every 28 days). (2.2)
- Adjust dose based on biochemical response and tolerability. (2.3)
- Evaluate fasting plasma glucose, hemoglobin A1c, liver enzyme tests, electrocardiogram (ECG), serum magnesium and serum potassium prior to starting. (2.5)
- Optimize glucose control in patients with poorly controlled diabetes mellitus prior to starting. (2.5)
- Patients with Hepatic Impairment:
 - Child-Pugh B*: Recommended initial dose is 20 mg every 4 weeks and maximum dose is 40 mg every 4 weeks (2.4, 8.6)
 - Child-Pugh C*: Avoid use in these patients (2.4, 8.6)
- Follow reconstitution and administration instructions. (2.6)

DOSAGE FORMS AND STRENGTHS

SIGNIFOR LAR for injectable suspension: 20 mg, 40 mg, and 60 mg, powder in a vial to be reconstituted with the provided 2mL diluent. (3)

CONTRAINDICATIONS

None. (4)

WARNINGS AND PRECAUTIONS

- Hyperglycemia and Diabetes*: Sometimes severe. Monitor glucose levels periodically during therapy. Monitor glucose levels more

frequently in the months that follow initiation or discontinuation of SIGNIFOR LAR therapy and following SIGNIFOR LAR dose adjustment. Use antidiabetic treatment if indicated per standard of care. (2.5, 5.1)

- Bradycardia and QT Prolongation*: Use with caution in at-risk patients; Evaluate ECG and electrolytes prior to dosing and periodically while on treatment. (2.5, 5.2, 7.1)
- Liver Test Elevations*: Evaluate liver enzyme tests prior to and during treatment. (2.5, 5.3)
- Cholelithiasis*: Monitor periodically. (5.4)
- Pituitary Hormone Deficiency(ies)*: Monitor for occurrence periodically and treat if clinically indicated. (5.5)

ADVERSE REACTIONS

Adverse drug reactions associated with SIGNIFOR LAR and occurring in $\geq 20\%$ of patients were diarrhea, cholelithiasis, hyperglycemia, and diabetes mellitus. (6)

To report SUSPECTED ADVERSE REACTIONS, contact Novartis Pharmaceuticals Corporation at 1-888-669-6682 or FDA at 1-800-FDA-1088 or www.fda.gov/medwatch.

DRUG INTERACTIONS

- Drugs that Prolong QT*: Use with caution in patients who are at significant risk of developing QTc prolongation. (5.2, 7.1)
 - Cyclosporine*: Consider additional monitoring. (7.2)
- Bromocriptine*: Consider bromocriptine dose reduction. (7.2)

USE IN SPECIFIC POPULATIONS

- Females and Males of Reproductive Potential: Advise premenopausal females of the potential for an unintended pregnancy (8.3)

See 17 for PATIENT COUNSELING INFORMATION and FDA-approved patient labeling

Revised: 03/2018

FULL PRESCRIBING INFORMATION: CONTENTS*

1 INDICATIONS AND USAGE

1.1 Acromegaly

2 DOSAGE AND ADMINISTRATION

- 2.1 Important Administration Instructions
- 2.2 Recommended Initial Dose
- 2.3 Dose Adjustment and Monitoring
- 2.4 Dose in Patients with Hepatic Impairment
- 2.5 Recommended Baseline Evaluations Prior to Initiation of SIGNIFOR LAR
- 2.6 Reconstitution and Intramuscular Injection Instructions
- 2.7 Missed Dose

3 DOSAGE FORMS AND STRENGTHS

4 CONTRAINDICATIONS

5 WARNINGS AND PRECAUTIONS

- 5.1 Hyperglycemia and Diabetes
- 5.2 Bradycardia and QT Prolongation
- 5.3 Liver Test Elevations
- 5.4 Cholelithiasis
- 5.5 Pituitary Hormone Deficiency(ies)

6 ADVERSE REACTIONS

- 6.1 Clinical Trials Experience

7 DRUG INTERACTIONS

- 7.1 Effect of Other Drugs on SIGNIFOR LAR
- 7.2 Effect of SIGNIFOR LAR on Other Drugs

8 USE IN SPECIFIC POPULATIONS

- 8.1 Pregnancy
- 8.2 Lactation
- 8.3 Females and Males of Reproductive Potential
- 8.4 Pediatric Use
- 8.5 Geriatric Use
- 8.6 Hepatic Impairment
- 8.7 Renal Impairment

10 OVERDOSAGE

11 DESCRIPTION

12 CLINICAL PHARMACOLOGY

- 12.1 Mechanism of Action
- 12.2 Pharmacodynamics
- 12.3 Pharmacokinetics

13 NONCLINICAL TOXICOLOGY

- 13.1 Carcinogenesis, Mutagenesis, Impairment of Fertility

14 CLINICAL STUDIES

- 14.1 Drug-Naïve Patients with Acromegaly
- 14.2 Patients with Acromegaly Inadequately Controlled on Other Somatostatin Analogs

16 HOW SUPPLIED/STORAGE AND HANDLING

17 PATIENT COUNSELING INFORMATION

* Sections or subsections omitted from the full prescribing information are not listed

FULL PRESCRIBING INFORMATION

1 INDICATIONS AND USAGE

1.1 Acromegaly

SIGNIFOR LAR is a somatostatin analog indicated for the treatment of patients with acromegaly who have had an inadequate response to surgery and/or for whom surgery is not an option.

2 DOSAGE AND ADMINISTRATION

2.1 Important Administration Instructions

SIGNIFOR LAR must be reconstituted by a trained healthcare professional immediately before use. Illustrations on reconstitution are found in Instructions for Use [*see Dosage and Administration (2.6)*].

SIGNIFOR LAR must be inspected visually before use. The suspension should appear free of foreign particulates and should be homogeneous after mixing.

SIGNIFOR LAR must be administered by a trained healthcare professional only by intramuscular injection in the right or left gluteus immediately after reconstitution. SIGNIFOR LAR must never be administered intravenously.

2.2 Recommended Initial Dose

The recommended initial dose of SIGNIFOR LAR is 40 mg administered by intramuscular injection once every 4 weeks (every 28 days) [*see Dosage and Administration (2.6)*].

2.3 Dose Adjustment and Monitoring

The dose may be increased to a maximum of 60 mg for patients who have not normalized growth hormone (GH) and/or age and sex adjusted insulin-like growth factor-1 (IGF-1) levels after 3 months of treatment with SIGNIFOR LAR at 40 mg and who tolerate this dose [*see Adverse Reactions (6) and Clinical Studies (14)*].

Management of SIGNIFOR LAR-related adverse reactions or over-response to treatment (age and sex adjusted IGF-1 less than the lower limit of normal) may require dose reduction. The dose may be decreased, either temporarily or permanently, by 20 mg decrements [*see Warnings and Precautions (5)*].

2.4 Dose in Patients with Hepatic Impairment

The recommended initial dose for patients with moderately impaired hepatic function (Child-Pugh B) is 20 mg every 4 weeks and the maximum recommended dose is 40 mg every 4 weeks. Avoid use in patients with severe hepatic impairment (Child-Pugh C) [*see Use in Specific Populations (8.6)*].

2.5 Recommended Baseline Evaluations Prior to Initiation of SIGNIFOR LAR

Prior to the initiation of SIGNIFOR LAR, it is recommended that patients have the following baseline evaluations:

- Fasting plasma glucose and hemoglobin A1c [*see Warnings and Precautions (5.1)*]
- Liver tests [*see Warnings and Precautions (5.3)*]
- Electrocardiogram, serum potassium and serum magnesium levels [*see Warnings and Precautions (5.2)*]

Patients with poorly controlled diabetes mellitus who have inadequate glucose control should have antidiabetic therapy optimized prior to starting SIGNIFOR LAR [*see Warnings and Precautions (5.1)*].

2.6 Reconstitution and Intramuscular Injection Instructions

After reconstitution of the 20 mg, 40 mg, or 60 mg SIGNIFOR LAR vials with the provided 2 mL diluent, the injectable suspension will have a final concentration of 10 mg/mL, 20 mg/mL and 30 mg/mL and should be delivered in its entirety.

PAY PARTICULAR ATTENTION:

There are 2 critical steps in the reconstitution of SIGNIFOR LAR. **Not following these 2 steps could result in failure to deliver the drug appropriately.**

- 1) **The injection kit must reach room temperature (see Step 1 in Instructions for Use).** Remove the SIGNIFOR LAR injection kit from refrigerated storage and let stand at room temperature for a minimum of 30 minutes before reconstitution, but do not exceed 24 hours.
- 2) After adding the diluent solution, **shake the vial moderately** in a horizontal direction for a minimum of 30 seconds **until uniform suspension is formed (see Step 4 in Instructions for Use).**

The following items are included in the injection kit:

- a) One vial containing SIGNIFOR LAR powder
- b) One prefilled syringe containing the diluent solution for reconstitution
- c) One vial adapter for drug product reconstitution
- d) One safety injection needle (20G x 1.5”)

Figure 1: Items Included in Injection Kit

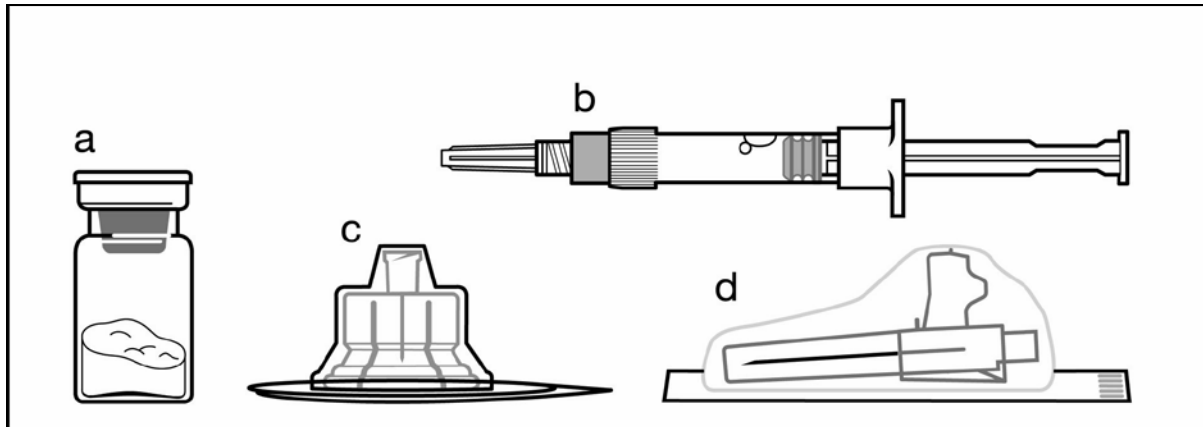

SIGNIFOR LAR suspension must only be reconstituted **immediately** before administration.

Follow the directions in the Instructions for Use to ensure proper reconstitution of SIGNIFOR LAR before intramuscular injection.

SIGNIFOR LAR should only be administered by a trained healthcare professional.

Instructions for Use

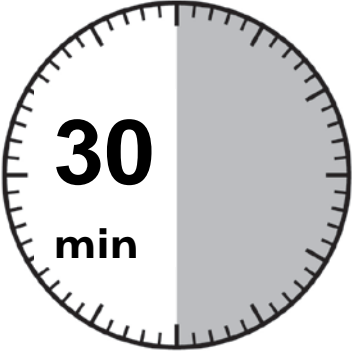
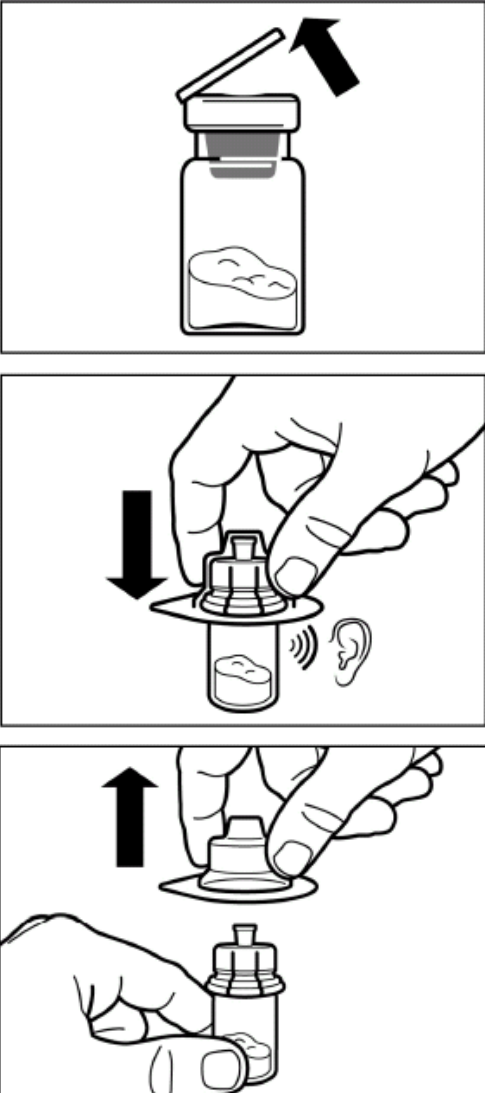
<p>Step 1</p> <p>Remove the SIGNIFOR LAR for injectable suspension kit from refrigerated storage.</p> <p>PAY PARTICULAR ATTENTION: It is essential to start the reconstitution process only after the injection kit has reached room temperature. Let the kit stand at room temperature for at least 30 minutes before starting reconstitution, but not more than 24 hours.</p> <p>Note: The kit can be re-refrigerated if needed.</p>	
<p>Step 2</p> <p>Remove the plastic cap from the vial and clean the rubber stopper with an alcohol wipe.</p> <p>Remove the lid film of the vial adapter packaging, but do NOT remove the vial adapter from its packaging.</p> <p>Holding the vial adapter packaging, position the vial adapter on top of the vial and push it fully down so that it snaps in place. You will hear an audible “click” when the vial adapter snaps in place.</p> <p>Lift the packaging off the vial adapter with a vertical movement.</p>	

Step 3

Remove the cap from the syringe prefilled with diluent solution and **screw** the syringe onto the vial adapter.

Slowly push the plunger all the way down to transfer all the diluent solution in the vial.

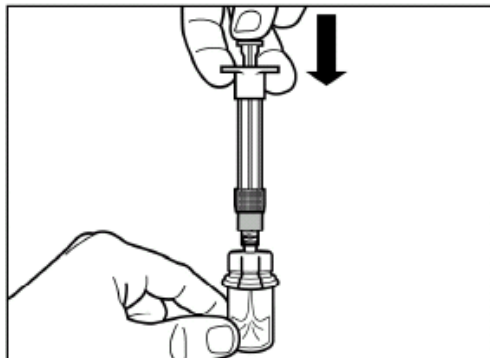
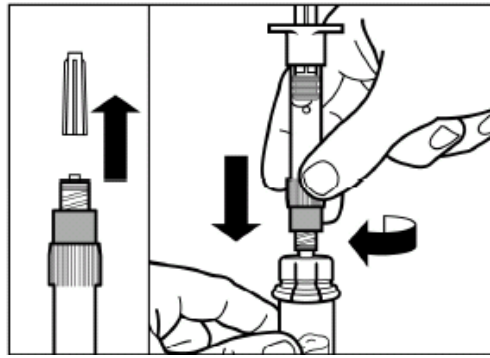

Step 4

ATTENTION: Keep the plunger pressed and shake the vial **moderately** in a horizontal direction for a **minimum of 30 seconds** so that the powder is completely suspended. **Repeat moderate shaking for another 30 seconds if the powder is not completely suspended.**

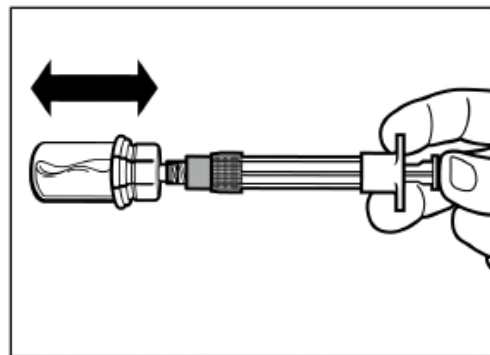

Step 5

Turn the syringe and vial upside down, **slowly** pull the plunger back and draw the entire content from the vial into the syringe.

Unscrew the syringe from the vial adapter.

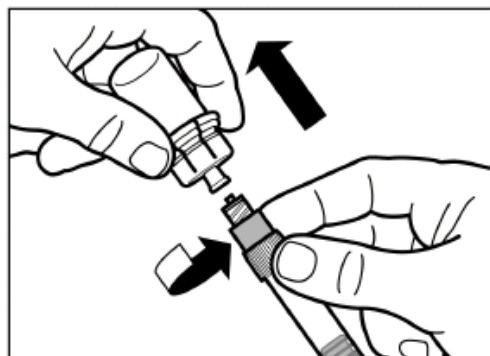
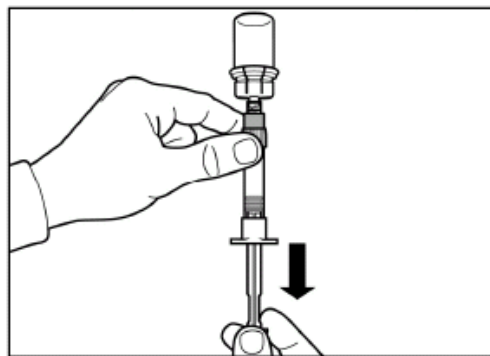

Step 6

Screw the safety injection needle onto the syringe.

Pull the protective cover straight off the needle.

To avoid sedimentation and maintain a uniform suspension, you may gently shake the syringe.

Gently tap the syringe to remove any visible bubbles and expel them from the syringe.

The reconstituted SIGNIFOR LAR is now ready for **immediate** administration.

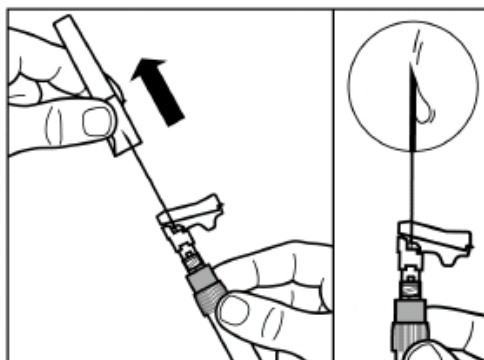
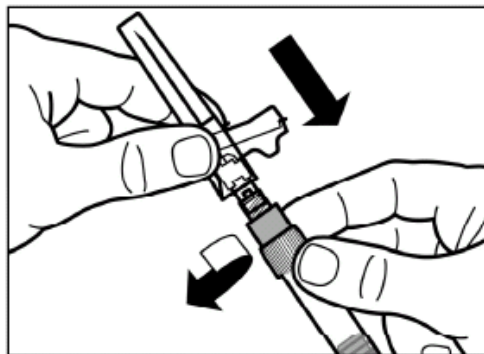

Step 7

SIGNIFOR LAR must only be given by intramuscular injection and **NEVER** intravenously.

Prepare the injection site by wiping with an alcohol wipe.

Insert the needle fully into the left or right gluteus at a 90° angle to the skin.

Slowly pull back the plunger to check that no blood vessel has been penetrated (reposition if a blood vessel has been penetrated).

Slowly depress the plunger until the syringe is empty. Withdraw the needle from the injection site and activate the safety guard (as shown in Step 8).

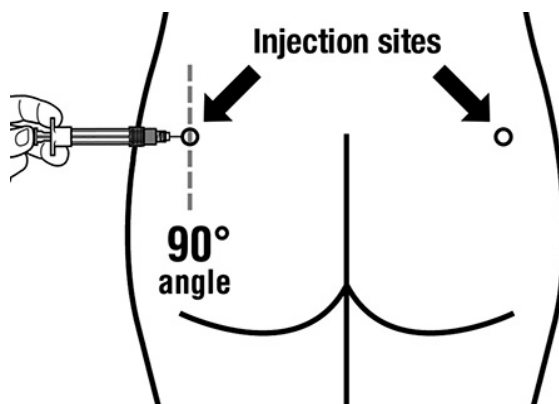

Step 8

Activate the safety guard over the needle using 1 of the 2 methods shown:

- either press the hinged section of the safety guard down onto a hard surface (figure A),
- or push the hinge forward with your finger (figure B).

An audible “click” will confirm proper activation of the safety guard.

Dispose of syringe immediately in a sharps container.

Any unused product or waste material should be disposed of in accordance with local requirements.

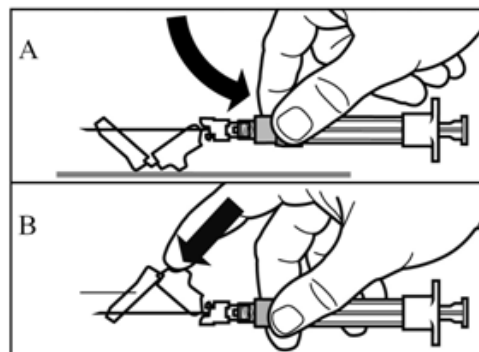

2.7 Missed Dose

If a dose is missed and the patient returns prior to the next scheduled dose, a dose may be given up to but no later than 14 days prior to the next dose.

3 DOSAGE FORMS AND STRENGTHS

SIGNIFOR LAR for injectable suspension: 20 mg, 40 mg, or 60 mg of pasireotide powder in a vial to be reconstituted with the provided 2 mL diluent.

4 CONTRAINDICATIONS

None.

5 WARNINGS AND PRECAUTIONS

5.1 Hyperglycemia and Diabetes

SIGNIFOR LAR can cause increases in blood glucose levels which are sometimes severe. In the study of patients with acromegaly, 5 patients naïve to drug therapy exposed to SIGNIFOR LAR (2 of whom were normoglycemic at baseline) were hospitalized for blood glucose in the range of 359–506 mg/dL and none in the active comparator group. Two additional patients who had received active comparator in the main trial were switched to SIGNIFOR LAR in the extension trial were hospitalized for elevated glucose levels while on SIGNIFOR LAR treatment during the extension; 1 of those patients developed diabetic ketoacidosis. Patients with poor baseline glycemic control are at higher risk of developing severe hyperglycemia [*see Dosage and Administration (2.5)*].

In the clinical development program, treatment with SIGNIFOR LAR caused an increase in the incidence of diabetes and prediabetes. A majority of patients, including those with normal glucose tolerance, prediabetes and diabetes, experienced increased glucose levels within the first 2 to 3 months of treatment with SIGNIFOR LAR [*see Adverse Reactions (6.1)*]. In the drug-naïve patient trial, the prevalence of diabetes increased from 30% at baseline to 60% at month 12. In the trial evaluating patients previously treated with somatostatin analogs, the prevalence of diabetes increased from 71% at baseline to 87% at month 6 in patients treated with SIGNIFOR LAR 40 mg and from 60% to 84% in patients treated with SIGNIFOR LAR 60 mg.

Fasting plasma glucose and hemoglobin A1c should be assessed prior to starting treatment with SIGNIFOR LAR. In patients with poorly controlled diabetes mellitus, antidiabetic treatment should be optimized before SIGNIFOR LAR treatment is started. Blood glucose monitoring should be done weekly for the first 3 months after initiating SIGNIFOR LAR and the first 4 to 6 weeks after dose increases. Periodic monitoring should continue thereafter, as clinically appropriate.

Patients who develop significant hyperglycemia on SIGNIFOR LAR may require initiation of antidiabetic therapy(ies) or adjustment in the dose or type of antidiabetic therapy(ies) per standard of care. The optimal treatment for the management of SIGNIFOR LAR-induced hyperglycemia is not known. If hyperglycemia cannot be controlled despite medical management, the dose of SIGNIFOR LAR should be reduced or SIGNIFOR LAR should be discontinued.

After treatment discontinuation, fasting plasma glucose and hemoglobin A1c should be assessed if indicated. Patients on antidiabetic therapy discontinuing SIGNIFOR LAR may require more frequent blood glucose monitoring and antidiabetic drug therapy dose adjustment to mitigate the risk of hypoglycemia.

5.2 Bradycardia and QT Prolongation

Bradycardia

Bradycardia has been reported with the use of SIGNIFOR LAR [*see Adverse Reactions (6.1)*]. Patients with cardiac disease and/or risk factors for bradycardia, such as history of clinically significant bradycardia, high-grade heart block, or concomitant use of drugs associated with bradycardia, should be monitored. Adjustments

in the dose of drugs known to slow the heart rate (e.g., beta-blockers, calcium channel blockers) and correction of electrolyte disturbances may be necessary when initiating or during the course of SIGNIFOR LAR treatment.

QT Prolongation

In cardiac electrophysiology studies (i.e., thorough QT studies) with pasireotide via subcutaneous route, QT prolongation occurred at therapeutic and supra-therapeutic doses [see *Clinical Pharmacology (12.2)*].

In the phase 3 trials, a corrected QT interval (i.e., QTcF) of greater than 480 ms was reported in 4 patients and an increase in the QTcF from baseline of greater than 60 ms was reported for 2 patients in the SIGNIFOR LAR arm. No patient on SIGNIFOR LAR had a QTcF value of greater than 500 ms [see *Adverse Reactions (6.1)* and *Clinical Pharmacology (12.2)*].

SIGNIFOR LAR should be used with caution in patients who are at significant risk of developing prolongation of the QT interval, such as those:

- with congenital long QT prolongation.
- with uncontrolled or significant cardiac disease including recent myocardial infarction, congestive heart failure, unstable angina or clinically significant bradycardia.
- on antiarrhythmic therapy or other substances that are known to lead to QT prolongation.
- with hypokalemia and/or hypomagnesemia.

A baseline ECG is recommended prior to initiating therapy with SIGNIFOR LAR. Monitoring for an effect on the QT interval at the time of maximum drug concentration (21 days after injection) should be obtained in patients at risk. Hypokalemia or hypomagnesemia must be corrected prior to initiating SIGNIFOR LAR and should be monitored periodically during therapy.

5.3 Liver Test Elevations

Increases in liver enzymes have been observed with SIGNIFOR LAR. Overall, in both phase 3 studies and across all doses, ALT or AST elevation greater than 3 times the upper limit of normal (ULN) were observed in 3% of patients and ALT or AST elevation greater than 5 times the upper limit of normal (ULN) were observed in 1% of patients treated with SIGNIFOR LAR.

Assessment of liver function is recommended prior to treatment with SIGNIFOR LAR, and after the first 2 to 3 weeks, then monthly for 3 months. Thereafter, liver function should be monitored as clinically indicated. Patients who develop increased transaminase levels should be monitored until values return to pretreatment levels. Treatment with SIGNIFOR LAR should be discontinued if signs or symptoms suggestive of clinically significant liver impairment develop. Following discontinuation of treatment with SIGNIFOR LAR, patients should be monitored until resolution. Treatment should not be restarted, if the liver function abnormalities are suspected to be related to SIGNIFOR LAR.

5.4 Cholelithiasis

Cholelithiasis was reported in 33% of drug-naïve and 10% of inadequately controlled (40 mg dose) acromegaly patients treated with SIGNIFOR LAR in clinical trials [see *Adverse Reactions (6)*]. Patients should be monitored periodically.

5.5 Pituitary Hormone Deficiency(ies)

Suppression of pituitary hormones other than GH/IGF-1, may occur on SIGNIFOR LAR. Monitoring pituitary function (e.g., thyroid, adrenal, gonadal) prior to initiation of therapy with SIGNIFOR LAR, as well as periodically during treatment, as clinically appropriate, is recommended. Patients should be monitored for and instructed on the signs and symptoms of adrenal insufficiency during therapy. If adrenal insufficiency is suspected it should be confirmed and treated per standard of care with exogenous glucocorticoids at replacement doses.

6 ADVERSE REACTIONS

Clinically significant adverse reactions that appear in other sections of the labeling include:

- Hyperglycemia and Diabetes [see Warnings and Precautions (5.1)]
- Bradycardia and QT Prolongation [see Warnings and Precautions (5.2)]
- Liver Test Elevations [see Warnings and Precautions (5.3)]
- Cholelithiasis [see Warnings and Precautions (5.4)]
- Pituitary Hormone Deficiency(ies) [see Warnings and Precautions (5.5)]

6.1 Clinical Trials Experience

Because clinical trials are conducted under widely varying conditions, adverse reaction rates observed in clinical trials of a drug cannot be directly compared to rates in clinical trials of another drug and may not reflect the rates observed in practice.

Drug-Naïve Patients with Acromegaly

The data described in Table 1 are derived from an active-controlled trial in patients with acromegaly naïve to previous drug therapy [see Clinical Studies (14.1)]. The data reflect exposure of 178 patients with acromegaly to SIGNIFOR LAR for a mean duration of 43 weeks. In the overall study population, 52% were female and the average age of patients was 45 years. Additional information on design and demographics of this trial are described below [see Clinical Studies (14.1)].

Table 1 presents common adverse reactions associated with SIGNIFOR LAR. These adverse reactions were not present at baseline or, if present, worsened from baseline and occurred in at least 5% of patients treated with SIGNIFOR LAR.

Table 1 - Adverse Reactions Occurring in \geq 5% of Patients Exposed to SIGNIFOR LAR in Patients with Acromegaly Naïve to Drug Therapy

Adverse Reaction Type	SIGNIFOR LAR (40-60 mg) % N=178	Active Comparator % N=180
Hyperglycemia Related Adverse Reactions		
Hyperglycemia	29	8
Diabetes mellitus*	26	4
Blood glucose increased	8	2
Glycosylated hemoglobin increased	6	2
Hypoglycemia	5	7
Gastrointestinal Related Adverse Reactions		
Diarrhea	39	45
Abdominal pain	18	22
Nausea	14	22
Abdominal distension	12	12
Vomiting	8	7
Abdominal pain upper	6	8
Hepatobiliary Related Adverse Reactions		
Cholelithiasis	26	36
Cardiac Related Adverse Reactions		
Sinus bradycardia**	10	7
Hypertension	8	7
Nervous System Related Adverse Reactions		
Headache	19	26
Dizziness	10	11

Skin Related Adverse Reactions		
Alopecia	18	19
Infections Related Adverse Reactions		
Nasopharyngitis	16	16
Influenza	8	4
Upper respiratory tract infection	7	3
Cough	5	8
Laboratory Related Adverse Reactions		
Blood creatine phosphokinase increased	13	12
Alanine aminotransferase increased	8	4
Aspartate aminotransferase increased	6	4
Weight decreased	5	4
General and Injection Site Related Adverse Reactions		
Fatigue	10	10
Injection site reaction***	7	7
Musculoskeletal and Connective Tissue Related Adverse Reactions		
Arthralgia	10	12
Back pain	8	11
Pain in extremity	7	4
Blood Related Adverse Reactions		
Anemia	6	6
* Diabetes mellitus includes the following PTs: Diabetes mellitus and type 2 diabetes mellitus ** Sinus bradycardia includes the following PTs: Bradycardia and sinus bradycardia *** Injection site reaction related AEs includes the following PTs: Injection site pain, Injection site reaction, Injection site haematoma, Injection site pruritus, Injection site swelling, Injection site erythema		

Other notable adverse reactions which occurred with a frequency of 5% or less for SIGNIFOR LAR were: adrenal insufficiency (3%); glucose tolerance impaired (1%); QT-prolongation (4%); blood amylase increased (2%).

Patients with Acromegaly Inadequately Controlled on other Somatostatin Analogs at Baseline

The data described in Table 2 are derived from an active-controlled study in patients with acromegaly inadequately controlled at baseline on other somatostatin analogs [see *Clinical Studies (14.2)*]. These data reflect exposure of 63 and 62 patients to SIGNIFOR LAR 40 mg and 60 mg, respectively, for a mean duration of 24 weeks.

In the overall study population, 56% were female and the average age of patients was 45 years. Additional information on design and demographics of this trial are described below [see *Clinical Studies (14.1)*].

Table 2 presents common adverse reactions associated with SIGNIFOR LAR. These common adverse reactions were not present at baseline or, if present, worsened from baseline and occurred in at least 5% of patients treated with SIGNIFOR LAR.

Table 2 – Adverse Reactions Occurring in ≥ 5% of Patients Exposed to SIGNIFOR LAR in Patients with Acromegaly Previously Treated with Other Somatostatin Analogs

Adverse Drug Reactions	SIGNIFOR LAR	SIGNIFOR LAR	Active Comparators
	40 mg % N=63	60 mg % N=62	% N=66
Hyperglycemia Related Adverse Reactions			
Hyperglycemia	33	30	14
Diabetes mellitus*	21	31	9
Blood glucose increased	5	7	0
Hypoglycemia	3	7	0

Gastrointestinal Related Adverse Reactions			
Diarrhea	16	19	5
Abdominal pain	8	8	3
Nausea	3	7	3
Hepatobiliary Related Adverse Reactions			
Cholelithiasis	10	13	14
Cardiac Related Adverse Reactions			
Atrioventricular block first degree	6	0	0
Nervous System Related Adverse Reactions			
Headache	14	3	5
Dizziness	8	2	3
Skin and Subcutaneous Tissue Related Adverse Reactions			
Alopecia	2	7	0
Infections Related Adverse Reactions			
Nasopharyngitis	6	11	3
Blood Related Adverse Reactions			
Anemia	6	3	3

* Diabetes mellitus includes the following PTs: diabetes mellitus and type 2 diabetes mellitus

Other notable adverse reactions which occurred with a frequency of 5% or less in the SIGNIFOR LAR 40 mg, SIGNIFOR LAR 60 mg arm, respectively, were adrenal insufficiency (2% and 0%) and glucose tolerance impaired (3% and 5%).

Hyperglycemia

The average fasting plasma glucose levels in patients with acromegaly naïve to drug therapy study [see *Clinical Studies (14.1)*] across visits is shown in Figure 2.

Figure 2. Mean Fasting Plasma Glucose (mg/dL) by Visit in the Study of Patients with Acromegaly Naïve to Drug Therapy*

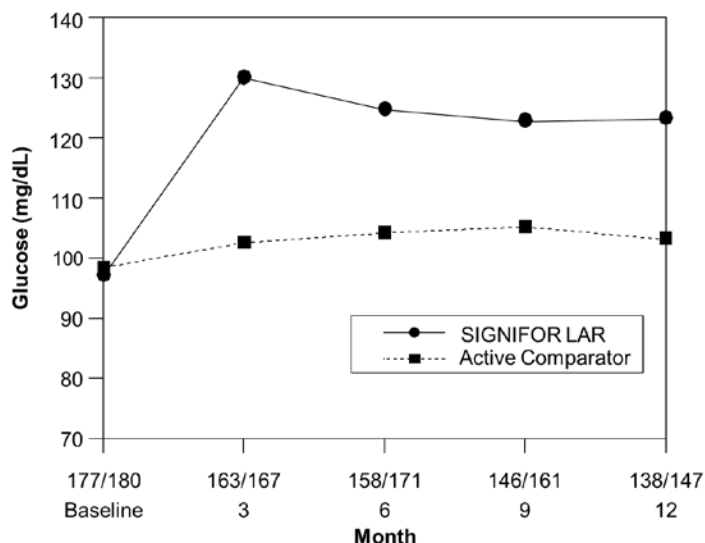

* Numbers of patients with a glucose value at the given timepoint in the SIGNIFOR LAR/Active comparator arms are displayed as xxx/xxx on the x axis

Pancreatic Enzyme Elevation and Pancreatitis

Asymptomatic, elevations in lipase and alpha amylase were observed in 30% and 20% of patients receiving SIGNIFOR LAR in the drug naïve study [see *Clinical Studies (14.1)*] and in 1% and 3% of patients receiving SIGNIFOR LAR in the study of patients previously treated [see *Clinical Studies (14.2)*]. In the drug-naïve

study, 2 patients receiving SIGNIFOR LAR developed pancreatitis. Pancreatitis is a potential adverse reaction associated with the use of SIGNIFOR LAR due to the association between cholelithiasis and acute pancreatitis.

7 DRUG INTERACTIONS

7.1 Effect of Other Drugs on SIGNIFOR LAR

Drugs that Prolong QT

Coadministration of drugs that prolong the QT interval with SIGNIFOR LAR may have additive effects on the prolongation of the QT interval. Monitor effects on QT interval at 21 days is recommended [*see Warnings and Precautions (5.2)*].

7.2 Effect of SIGNIFOR LAR on Other Drugs

Cyclosporine

Concomitant administration of cyclosporine with SIGNIFOR LAR may decrease the relative bioavailability of cyclosporine and, therefore, dose adjustment of cyclosporine to maintain therapeutic levels may be necessary.

Bromocriptine

Coadministration of SIGNIFOR LAR with bromocriptine may increase the blood levels of bromocriptine. Dose reduction of bromocriptine may be necessary.

8 USE IN SPECIFIC POPULATIONS

8.1 Pregnancy

Risk Summary

The limited data with SIGNIFOR LAR in pregnant women are insufficient to inform a drug-associated risk for major birth defects and miscarriage. In embryofetal development studies in rabbits, findings indicating a developmental delay were observed with subcutaneous administration of pasireotide during organogenesis at doses less than the exposure in humans at the highest recommended dose; maternal toxicity was not observed at this dose [*see Data*].

The estimated background risk of major birth defects and miscarriage for the indicated population is unknown. In the U.S. general population, the estimated background risk of major birth defects and miscarriage in clinically recognized pregnancies is 2-4% and 15-20%, respectively.

Data

Animal Data

In embryofetal development studies in rats given 1, 5, and 10 mg/kg/day subcutaneously throughout organogenesis, maternal toxicity was observed at all doses, including the lowest dose tested which had exposures 12 times higher than that at the maximum therapeutic dose based on AUC comparisons across species. An increased incidence of early/total resorptions and malrotated limbs was observed in rats at 10 mg/kg/day. At 10 mg/kg/day in rats, the maternal systemic exposure (AUC) was 42179 ng*hr/mL, approximately 106 times the exposure in humans at the highest recommended dose of 60 mg SIGNIFOR LAR administered as an intramuscular injection once every 4 weeks.

In embryofetal development studies in rabbits given 0.05, 1, and 5 mg/kg/day subcutaneously through organogenesis, maternal toxicity was observed at 1 mg/kg/day, at a maternal systemic exposure (AUC) of 1906 ng*hr/mL, approximately 5 times higher than the maximum human therapeutic exposure. An increased incidence of unossified forepaw phalanx, indicative of a developmental retardation, was observed in rabbits at 0.05 mg/kg/day, with maternal systemic exposures less than the systemic exposure in humans at the highest recommended dose.

In pre- and post-natal developmental studies in rats given subcutaneous doses of 2, 5, and 10 mg/kg/day during gestation through lactation and weaning, maternal toxicity was observed at all doses including the lowest dose

(9 times higher than the maximum therapeutic dose based on surface area comparisons across species). Retardation of physiological growth, attributed to GH inhibition was observed at 2 mg/kg/day during a pre- and post-natal study in rats. After weaning, body weight gains in the rat pups (F1 generation) exposed to pasireotide were comparable to controls, showing reversibility of this developmental delay.

8.2 Lactation

Risk Summary

There is no information available on the presence of SIGNIFOR LAR in human milk, the effects of the drug on the breastfed infant, or the effects of the drug on milk production. Studies show that pasireotide administered subcutaneously passes into the milk of lactating rats; however, due to species-specific differences in lactation physiology, animal data may not reliably predict drug levels in human milk [see Data]. The developmental and health benefits of breastfeeding should be considered along with the mother's clinical need for SIGNIFOR LAR and any potential adverse effects on the breast-fed child from SIGNIFOR LAR or from the underlying maternal condition.

Data

Available data in animals have shown excretion of pasireotide in milk. After a single 1 mg/kg [¹⁴C]-pasireotide subcutaneous dose to lactating rats, the transfer of radioactivity into milk was observed. The overall milk:plasma (M/P) exposure ratio of total radioactivity was 0.28, based on AUC_{0-∞} values.

8.3 Females and Males of Reproductive Potential

Discuss the potential for unintended pregnancy with premenopausal women as the therapeutic benefits of a reduction in growth hormone (GH) levels and normalization of insulin-like growth factor (IGF-1) in acromegalic females treated with pasireotide may lead to improved fertility.

8.4 Pediatric Use

Safety and effectiveness of SIGNIFOR LAR have not been established in pediatric patients.

8.5 Geriatric Use

Clinical studies of SIGNIFOR LAR did not include sufficient numbers of subjects aged 65 and over to determine whether they respond differently from younger subjects. Other reported clinical experience has not identified differences in responses between the elderly and younger patients. In general, dose selection for an elderly patient should be cautious, usually starting at the low end of the dosing range, reflecting the greater frequency of decreased hepatic, renal, or cardiac function, and of concomitant disease or other drug therapy.

8.6 Hepatic Impairment

Dose adjustment is not required in patients with mild impaired hepatic function (Child-Pugh A), but is required for patients with moderately impaired hepatic function (Child-Pugh B). The safety and efficacy of SIGNIFOR LAR have not been established in patients with severe hepatic impairment (Child-Pugh C). No dosage recommendation can be given for patients with severe hepatic impairment (Child-Pugh C) [see Dosage and Administration (2.3) and Clinical Pharmacology (12.3)].

8.7 Renal Impairment

Clinical studies of SIGNIFOR LAR in patients with renal impairment have not been conducted. On the basis of studies with pasireotide given subcutaneously, dosage adjustment is not needed in patients with renal impairment [see Clinical Pharmacology (12.3)].

10 OVERDOSAGE

In the event of overdosage, it is recommended that appropriate supportive treatment be initiated, as dictated by the patient's clinical status, until resolution of the symptoms.

Up-to-date information about the treatment of overdose can be obtained from a certified Regional Poison Center. In the event of an overdose, contact the National Capital Poison Center at 1-800-222-1222 or www.poison.org.

11 DESCRIPTION

SIGNIFOR LAR (pasireotide) for injectable suspension is a long-acting release form of pasireotide pamoate, as powder to be suspended in the provided diluent immediately prior to intramuscular injection. SIGNIFOR LAR is a somatostatin analog. Pasireotide pamoate, chemically known as (2-Aminoethyl) carbamic acid (2R,5S,8S,11S,14R,17S,19aS)-11-(4-aminobutyl)-5-benzyl-8-(4-benzyloxybenzyl)-14-(1H-indol-3-ylmethyl)-4,7,10,13,16,19-hexaoxo-17-phenyloctadecahydro-3a,6,9,12,15,18-hexaazacyclopentacyclooctadecen-2-yl ester pamoic acid salt, is a cyclohexapeptide with pharmacologic properties mimicking those of the natural hormone somatostatin.

The molecular formula of pasireotide pamoate is $C_{58}H_{66}N_{10}O_9 \cdot C_{23}H_{16}O_6$ and the molecular weight is 1435.58.

The structural formula is:

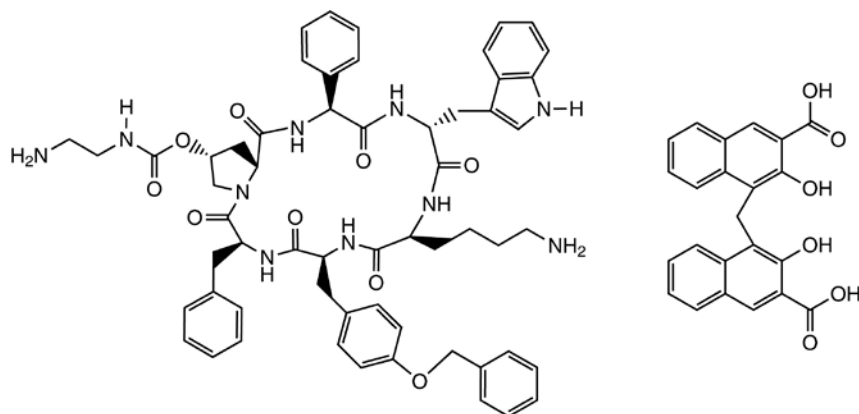

The drug product consists of pasireotide pamoate uniformly distributed within microspheres which are made of biodegradable copolymers of poly (D,L-lactide-co-glycolide) acids (PLGA).

SIGNIFOR LAR is available in a vial containing the sterile pasireotide pamoate, PLGA microspheres powder, 20 mg, 40 mg and 60 mg to be reconstituted with the provided 2 mL sterile diluent. The product should be prepared immediately prior to use for intramuscular injection given once every 4 weeks.

Each vial contains:

	20 mg	40 mg	60 mg
Pasireotide pamoate	27.42 mg*	54.84 mg*	82.26 mg*
Poly(D,L-lactide-co-glycolide) [50-60:40-50]	26.29 mg	52.58 mg	78.87 mg
Poly(D,L-lactide-co-glycolide) [50:50]	26.29 mg	52.58 mg	78.87 mg

*Corresponds to 20 mg, 40 mg and 60 mg of pasireotide base, respectively.

Each diluent prefilled syringe contains:

Mannitol	90 mg
Carboxymethylcellulose sodium	14 mg
Poloxamer 188	4 mg
Water for injections	add to 2 mL

12 CLINICAL PHARMACOLOGY

12.1 Mechanism of Action

SIGNIFOR LAR is an injectable cyclohexapeptide, somatostatin analog. Pasireotide exerts its pharmacological activity via binding to somatostatin receptors (SSTR). There are 5 known human somatostatin receptor

subtypes: SSTR 1, 2, 3, 4, and 5. These receptor subtypes are expressed in different tissues under normal physiological conditions. Somatostatin analogs bind to SSTRs with different potencies. Pasireotide binds with high affinity to 4 of the 5 SSTRs (see Table 3).

Table 3 – Binding Affinities of Somatostatin (SRIF-14) Pasireotide to the Five Human SSTR Subtypes (SSTR 1-5)

Compound	SSTR1	SSTR2	SSTR3	SSTR4	SSTR5
Somatostatin (SRIF-14)	0.93±0.12	0.15±0.02	0.56±0.17	1.5±0.4	0.29±0.04
Pasireotide	9.3±0.1	1.0±0.1	1.5±0.3	>100	0.16±0.01

Results are the mean±SEM of IC₅₀ values expressed as nmol/l (nM).

12.2 Pharmacodynamics

Somatostatin receptors are expressed in many tissues including neuroendocrine tumors (e.g., growth hormone secreting pituitary adenomas). Pasireotide binds to SSTR2 and SSTR5 subtype receptors which may be relevant for inhibition of GH secretion. In vivo studies show that SIGNIFOR LAR lowers GH and IGF-1 levels in patients with acromegaly.

Cardiac Electrophysiology

Individually corrected QT (QTcI) interval was evaluated in a randomized, blinded, crossover study in healthy subjects investigating pasireotide subcutaneous doses of 0.6 mg and 1.95 mg twice daily, respectively. The maximum mean (95% upper confidence bound) placebo-subtracted QTcI change from baseline was 12.7 (14.7) ms and 16.6 (18.6) ms, respectively. Both pasireotide doses decreased heart rate, with a maximum mean (95% lower confidence bound) placebo-subtracted change from baseline of -10.9 (-11.9) beats per minute (bpm) observed at 1.5 hours for pasireotide 0.6 mg twice daily, and -15.2 (-16.5) bpm at 0.5 hours for pasireotide 1.95 mg twice daily.

The predicted peak concentrations for the SIGNIFOR LAR dose of 60 mg in acromegaly patients are similar to the observed peak concentration (24.3 mg/mL) of the subcutaneous SIGNIFOR 0.6 mg twice daily dose and below the observed peak concentration (80.6 ng/mL) of the subcutaneous SIGNIFOR 1.95 mg twice daily dose.

12.3 Pharmacokinetics

Absorption and Distribution:

No studies have been conducted to evaluate the absolute bioavailability of pasireotide in humans. Food effect is unlikely to occur since SIGNIFOR LAR is administered via a parenteral route.

In healthy volunteers, pasireotide administered as SIGNIFOR LAR is widely distributed with large apparent volume of distribution ($V_z/F > 100$ L). Distribution between blood and plasma is concentration-independent and shows that pasireotide is primarily located in the plasma (91%). Plasma protein binding is moderate (88%) and independent of concentration.

Pasireotide has low passive permeability and is likely to be a substrate of P-gp (P-glycoprotein), but the impact of P-gp on the ADME (absorption, distribution, metabolism, excretion) of pasireotide is expected to be low. In clinical testing in healthy volunteers, P-gp inhibition did not affect the rate or extent of pasireotide availability [see *Drug Interactions (7.1)*]. At therapeutic dose levels, pasireotide is not expected to be a substrate of BCRP (breast cancer resistance protein), OCT1 (organic cation transporter 1), or OATP (organic anion-transporting polypeptides) 1B1, 1B3, or 2B1.

Metabolism and Excretion:

Pasireotide was shown to be highly metabolically stable in human liver and kidney microsomes. In healthy volunteers, pasireotide in its unchanged form is the predominant form found in plasma, urine and feces. Somatropin may increase CYP450 enzymes and, therefore, suppression of growth hormone secretion by somatostatin analogs including pasireotide may decrease the metabolic clearance of compounds metabolized by CYP450 enzymes.

Pasireotide is eliminated mainly via hepatic clearance (biliary excretion) with a small contribution of the renal route. In a human ADME study with subcutaneous SIGNIFOR with a single dose 0.6 mg, $55.9 \pm 6.63\%$ of the radioactivity dose was recovered over the first 10 days post dosing, including $48.3 \pm 8.16\%$ of the radioactivity in feces and $7.63 \pm 2.03\%$ in urine.

The apparent clearance (CL/F) of SIGNIFOR LAR in healthy volunteers is on average 4.5–8.5 liters/hour.

Steady-State Pharmacokinetics:

PK steady-state for SIGNIFOR LAR is achieved after 3 months. Following multiple intramuscular doses every 4 weeks (every 28 days), SIGNIFOR LAR demonstrates approximately dose-proportional PK exposures in the dose range of 20 mg to 60 mg every 4 weeks in patients with acromegaly.

Special Populations:

Population PK analyses of SIGNIFOR LAR suggest that race, gender and body weight do not have clinically relevant influence on circulating levels of pasireotide. No dose adjustment is required for demographics.

Pediatric Patients

No studies have been performed in pediatric patients [*see Use in Specific Populations (8.4)*].

Geriatric Patients

Age is not a significant covariate in the population PK analysis of patients with acromegaly. Therefore age is not expected to significantly impact circulating levels of pasireotide.

Efficacy and safety data on patients with acromegaly older than 65 years are limited [*see Use in Specific Populations (8.5)*].

Hepatic Impairment

In a clinical study with a single subcutaneous dose of 600 µg pasireotide in subjects with impaired hepatic function (Child-Pugh A, B and C), subjects with moderate and severe hepatic impairment (Child-Pugh B and C) showed significantly higher exposures than subjects with normal hepatic function. Upon comparing with the control group, AUC_{inf} was increased by 12%, 56%, and 42% and C_{max} was increased by 3%, 46%, and 33% respectively, in the mild, moderate, and severe hepatic impairment groups [*see Use in Specific Populations (8.6) and Dosage and Administration (2.3)*].

Renal Impairment

Renal clearance has a minor contribution to the elimination of pasireotide in humans. In a clinical study with a single subcutaneous dose of 900 µg pasireotide in subjects with impaired renal function, renal impairment of mild, moderate, or severe degree or end stage renal failure did not have a significant impact on the pharmacokinetics of pasireotide [*see Use in Specific Populations (8.7)*].

13 NONCLINICAL TOXICOLOGY

13.1 Carcinogenesis, Mutagenesis, Impairment of Fertility

Carcinogenesis

A lifetime carcinogenicity study was conducted in rats and transgenic mice. Rats were given daily subcutaneous doses of pasireotide at 0.01, 0.05, and 0.3 mg/kg/day for 104 weeks. There were no drug-related tumors in rats at exposures up to 5 times higher than the maximum recommended clinical exposure of the pasireotide LAR 60 mg dose. Mice were given subcutaneous doses of pasireotide at 0.5, 1.0, and 2.5 mg/kg/day for 26 weeks and did not identify any carcinogenic potential.

Mutagenesis

Pasireotide was not genotoxic in a battery of in vitro assays (Ames mutation test in *Salmonella* and *E. coli*. and mutation test in human peripheral lymphocytes). Pasireotide was not genotoxic in an in vivo rat bone marrow nucleus test.

Impairment of Fertility

Subcutaneous dosing at 0.1 mg/kg/day before mating and continuing into gestation in rats at exposures less than the human clinical exposure based on body surface area comparisons across species resulted in statistically significant increased implantation loss and decreased viable fetuses, corpora lutea, and implantation sites. Abnormal cycles or acyclicity were observed at 1 mg/kg/day (4-fold higher than the maximum therapeutic exposure of pasireotide LAR based on surface area, comparisons across species).

14 CLINICAL STUDIES

14.1 Drug-Naïve Patients with Acromegaly

A multicenter, randomized, double-blind study was conducted to assess the safety and efficacy of SIGNIFOR LAR in patients with active acromegaly. A total of 358 patients naïve to drugs used to treat acromegaly were randomized in a 1:1 ratio to SIGNIFOR LAR or another somatostatin analog active comparator. Randomization was stratified based on previous pituitary surgical status (e.g., at least 1 prior pituitary surgery versus no prior pituitary surgery).

In the overall study population, 52% were female and the average age of patients was 45 years. Sixty percent of patients were Caucasian, 23% Asian, 12% Other, 3% American Indian and 2% were Black. Forty-two percent of patients had previous pituitary surgery and 1 patient had a history of pituitary radiation therapy. Median time between diagnosis and trial participation was 6 months. Median GH was 8.8 mcg/L (range: 0.8–200 mcg/L) and 10.1 mcg/L (range: 0.6–169.6 mcg/L) for SIGNIFOR LAR and active comparator, respectively at baseline. Median standardized IGF-1, defined as IGF-1 value divided by the ULN (i.e., fold above the ULN), was 2.9 (range: 0.9–6.9) and 2.9 (range: 0.8–7.3), for SIGNIFOR LAR and active comparator, respectively, at baseline.

The starting dose of SIGNIFOR LAR was 40 mg. Dose increase was allowed in both arms, at the discretion of investigators, after 3 and 6 months of treatment if mean GH was greater than or equal to 2.5 mcg/L and/or IGF-1 was greater than the ULN for age and sex. The maximum allowed dose for SIGNIFOR LAR was 60 mg. The maximum dose of the active comparator was not used in this trial because the trial was multi-national and the maximum dose approved in the US was not approved in all participating countries.

The efficacy endpoint was the proportion of patients with a mean GH level less than 2.5 mcg/L and a normal IGF-1 levels at month 12 (age- and sex-adjusted) (see Table 4, Figure 3 and Figure 4). The proportion of patients achieving this level of control was 31.3% and 19.2% for SIGNIFOR LAR and active comparator, respectively. The changes in mean GH and IGF-1 levels by study visits in subjects with a measurement at these visits (observed cases) are shown in Figures 3 and 4.

Table 4 – Results at Month 12 in Drug-Naïve Patients Study

	SIGNIFOR LAR (40–60 mg) % N=176	Active Comparator ^{&} % N=182
GH<2.5mcg/L and normalized IGF-1*	31.3**	19.2
GH<2.5mcg/L and IGF-1 ≤ULN	35.8	20.9
Normalized IGF-1	38.6**	23.6
GH<2.5 mcg/L	48.3	51.6

* Primary endpoint (patients with IGF-1<lower limit of normal (LLN) were not considered as “responders”)
ULN = Upper limit of normal
** p-value <0.01 for treatment difference
& The maximum dose approved for use in the United States was not used in this trial but the majority of patients were receiving the dose most commonly used in the United States to treat acromegaly

Figure 3: Mean GH (mcg/L) Levels by Visit in Drug Naïve Patient Study*

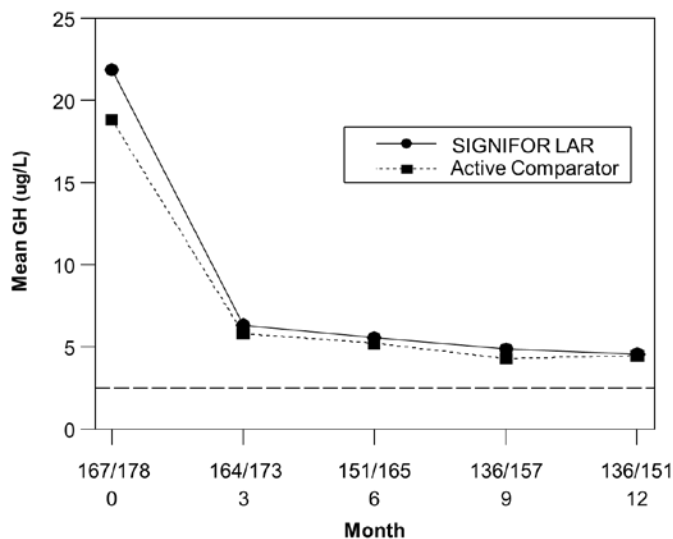

* Numbers of patients with a GH value at the given timepoint for SIGNIFOR LAR/Active comparator arm are displayed as xxx/xxx on the x axis.

Figure 4: Mean Standardized IGF-1 Levels* by Visit in Drug Naïve Patient Study**

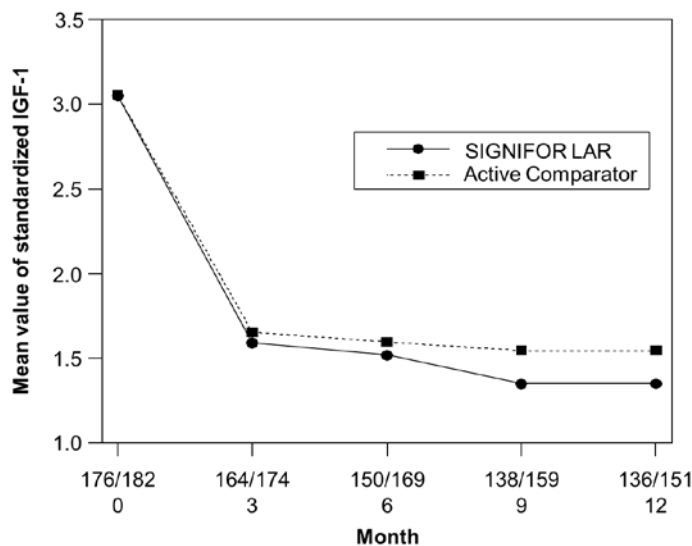

*Fold above the upper limit of normal for the assay

** Numbers of patients with an IGF-1 value at the given timepoint for SIGNIFOR LAR/Active comparator arm are displayed as xxx/xxx on the x axis.

Biochemical control was achieved by Month 3 in 30.1% of patients in the SIGNIFOR LAR arm. Ninety-eight percent of patients treated with SIGNIFOR LAR had either a reduction or no change in tumor volume from baseline assessed by MRI at month 12. The median (range) change in tumor volume was a reduction of 39.8% (-97.6% to 16.9%).

Additionally, ring size and acromegaly symptoms score (i.e. headache, fatigue, perspiration, paresthesia, and osteoarthralgia) were followed. At month 12, reductions in ring size and in symptom severity scores in both treatment groups compared to baseline were noted.

14.2 Patients with Acromegaly Inadequately Controlled on Other Somatostatin Analogs

A multicenter, randomized, 3-arm trial was conducted in patients with acromegaly inadequately controlled on somatostatin analogs. Patients were randomized to double-blind SIGNIFOR LAR 40 mg (n=65) or SIGNIFOR LAR 60 mg (n=65) or to continued open-label pretrial somatostatin analog therapies at maximal or near maximal doses (n=68). A total of 181 patients completed the 6 month trial.

Inadequate control was defined as a GH concentration of greater than 2.5 mcg/L (i.e., mean of 5 samples over 2 hours) and a sex- and age-adjusted IGF-1 level greater than 1.3 times the upper limit of normal. Patients were required to have been treated with other somatostatin analogs for at least 6 months prior to randomization. Note that the maximum dose for one of the active comparators approved for use in the United States was not used in this multinational trial; approximately 75% of the population in the comparator group was receiving this active comparator.

In the overall study population, 56% were female and the average age of patients was 45 years. Eighty-one percent of patients were Caucasian, 7% Other, 8% Black, 2% American Indian and 2% Asian. The percentage of patients with previous pituitary surgery in the SIGNIFOR LAR 40 mg and 60 mg arms and in the active control arm was 77%, 63% and 60%, respectively. Three percent (3%) of patients in the SIGNIFOR LAR groups and 7% of patients in the active control arm had prior radiation therapy. Median (range) time from diagnosis to participation in this trial was 50 (10–337) months, 55 (8–357) months, and 54 (8–357) months in the SIGNIFOR LAR 40 mg, 60 mg and the pretrial therapy arms, respectively. At baseline, median (range) GH was 7.1 (1.0–200) mcg/L, 5.3 (1.4–113.8) mcg/L and 6.1 (1.0–92.4) mcg/L in the SIGNIFOR LAR 40 mg, 60 mg and the pretrial therapy arms, respectively. Baseline median standardized IGF-1 (defined as IGF-1 value divided by the ULN) values were 2.3, 2.6 and 2.9 in the SIGNIFOR LAR 40 mg, 60 mg and the pretrial therapy arms, respectively.

The efficacy endpoint was the proportion of patients with a mean GH level less than 2.5 mcg/L and normal IGF-1 levels at week 24. The primary analysis compared SIGNIFOR LAR 60 mg and 40 mg to continued pretrial therapy (i.e., no change in treatment). The proportion of patients achieving biochemical control was 15.4% and 20.0% for SIGNIFOR LAR 40 mg and 60 mg, respectively, at 6 months.

Biochemical control was achieved by Month 3 in 15.4% and 18.5% of patients in the SIGNIFOR LAR 40 mg and 60 mg arms, respectively.

Table 5 – Results at 6 Months in Inadequately Controlled Patient Study

	SIGNIFOR LAR 40 mg	SIGNIFOR LAR 60 mg	Continued Pretrial Therapy Control Arm ^{&}
	%	%	%
	N=65	N=65	N=68
GH<2.5 mcg /L and normalized IGF-1*	15.4	20.0	0
Normalization of IGF-1	24.6	26.2	0
GH<2.5 mcg /L	35.4	43.1	13.2

* Primary endpoint (patients with IGF-1< lower limit of normal (LLN) were not considered as “responders”).

[&] For one of the active comparators, the maximum dose approved for use in the United States was not used in this trial but the majority of patients were receiving the dose most commonly used in the United States to treat acromegaly.

Eighty-one percent and 70 percent of patients treated with SIGNIFOR LAR 40 mg and 60 mg, respectively, had either a reduction or no change in tumor volume from baseline assessed by MRI at month 6. The median (range) change in tumor volume was a reduction of -10.4% (-74.5% to 19.4%) and -6.3% (-66.7% to 14.5%) from baseline for SIGNIFOR LAR 40 mg and 60 mg, respectively.

16 HOW SUPPLIED/STORAGE AND HANDLING

SIGNIFOR LAR (pasireotide) for injectable suspension is supplied in a single-use kit containing the following:

- One 6-mL brownish glass vial with a grey rubber stopper of SIGNIFOR LAR containing slightly yellow to yellow powder capped with 20 mg (gray flip-off cap), 40 mg (red flip-off cap), or 60 mg (orange flip-off cap)
- One 3-mL glass barrel/grey rubber stopper prefilled syringe containing 2 mL of clear, colorless to slightly yellow/brown diluent solution for reconstitution
- One sterile 20G x 1.5” stainless steel, polypropylene safety injection needle
- One vial adapter made of polycarbonate for drug product reconstitution

After reconstitution of the 20 mg, 40 mg, or 60 mg SIGNIFOR LAR vials with the provided 2 mL diluent, the injectable suspension will have a final concentration of 10 mg/mL, 20 mg/mL and 30 mg/mL and should be delivered in its entirety.

Drug Product Kits:

20 mg kit	NDC 0078-0641-81
40 mg kit	NDC 0078-0642-81
60 mg kit	NDC 0078-0643-81

Store at 2°C–8°C (36°F–46°F). Do not freeze.

SIGNIFOR LAR should be stored at refrigerated temperatures between 2°C–8°C (36°F–46°F) until the time of use. SIGNIFOR LAR drug product kit should remain at room temperature for a minimum of 30 minutes before reconstitution, but should not exceed 24 hours at room temperature. However, after preparation of the drug suspension, it must be administered immediately.

17 PATIENT COUNSELING INFORMATION

See FDA-approved patient labeling (*Patient Information*).

Counsel patients on the following possible significant adverse reactions:

- Hyperglycemia and Diabetes [*see Warnings and Precautions (5.1)*]
- Bradycardia and QT Prolongation [*see Warnings and Precautions (5.2)*]
- Liver Test Elevations [*see Warnings and Precautions (5.3)*]
- Cholelithiasis [*see Warnings and Precautions (5.4)*]
- Pituitary Hormone Deficiency(ies) [*see Warnings and Precautions (5.5)*]
- Pregnancy: Inform female patients that treatment with SIGNIFOR LAR may result in unintended pregnancy [*see Females and Males of Reproductive Potential (8.3)*].

Instruct patients on the importance of adhering to their return visit schedule.

Advise patients that SIGNIFOR LAR should only be administered by a trained healthcare professional.

This label may not be the latest approved by FDA.
For current labeling information, please visit <https://www.fda.gov/drugsatfda>

Distributed by:
Novartis Pharmaceuticals Corporation
East Hanover, NJ 07936

T2016-XX
Month Year

Patient Information
SIGNIFOR® LAR (sig-na-for L.A.R.)
(pasireotide)
for injectable suspension, for intramuscular use

Read this Patient Information before you start receiving SIGNIFOR LAR, and each time you receive it. There may be new information. This leaflet does not take the place of talking to your healthcare provider about your medical condition or your treatment.

What is SIGNIFOR LAR?

SIGNIFOR LAR is a prescription medicine used to treat people with acromegaly for whom surgery has not worked well enough or who cannot have surgery.

It is not known if SIGNIFOR LAR is safe and effective for use in children.

What should I tell my healthcare provider before receiving SIGNIFOR LAR?

Before you receive SIGNIFOR LAR, tell your healthcare provider if you:

- have high blood sugar (hyperglycemia)
- have diabetes
- have or have had heart problems, including an abnormal heart rate or rhythm or problems with the electrical system of your heart (QT prolongation)
- have a low level of potassium or magnesium in your blood
- have liver problems
- have gallstones (cholelithiasis)
- have any other medical conditions
- are pregnant or planning to become pregnant. SIGNIFOR LAR may harm your unborn baby.
- are breastfeeding or planning to breastfeed. It is not known if SIGNIFOR LAR passes into your breast milk. You and your healthcare provider should decide if you will receive SIGNIFOR LAR or breastfeed. You should not do both.

Tell your healthcare provider about all the medicines you take, including prescription and over-the-counter medicines, vitamins, and herbal supplements.

SIGNIFOR LAR and other medicines may affect each other, causing side effects. SIGNIFOR LAR may affect the way other medicines work, and other medicines may affect how SIGNIFOR LAR works. Your healthcare provider may need to change your dose of SIGNIFOR LAR. Especially tell your healthcare provider if you take:

- medicines to control your heart beat (antiarrhythmics)
- medicines to control your blood pressure (such as beta-blockers or calcium channel blockers)
- medicines to control the potassium and magnesium (electrolytes) levels in your body
- medicines that may affect the way the electrical system of your heart works (QT prolongation)
- cyclosporine
- bromocriptine

Ask your healthcare provider for a list of these medicines if you are not sure.

Know the medicines you take. Keep a list of them to show to your healthcare provider and pharmacist when you get a new medicine.

How will I receive SIGNIFOR LAR?

- SIGNIFOR LAR must be given by a trained healthcare provider as an injection into the muscle of your buttocks (intramuscularly).
- Your healthcare provider will tell you how much SIGNIFOR LAR you will receive and when you will receive it.
- Your healthcare provider may change your dose of SIGNIFOR LAR or the length of time between your injections. Your healthcare provider will tell you how long you need to receive SIGNIFOR LAR.
- Before you receive SIGNIFOR LAR for the first time, your healthcare provider should do a blood test to check your fasting blood sugar level, electrolyte levels, and your liver function.

Before you receive SIGNIFOR LAR for the first time and during your treatment, your healthcare provider should do a test to check your heart (electrocardiogram).

What are the possible side effects of SIGNIFOR LAR?

SIGNIFOR LAR may cause serious side effects, including:

- **high blood sugar (hyperglycemia) and diabetes.** Your healthcare provider should check your blood sugar level before you start receiving SIGNIFOR LAR and while you receive it. Tell your healthcare provider if you have any of these symptoms:
 - feel very thirsty
 - urinate more than usual
 - increased appetite with weight loss
 - tiredness

If you get hyperglycemia while receiving SIGNIFOR LAR, your healthcare provider may give you another medicine to lower your blood sugar. Your healthcare provider may also change your dose of SIGNIFOR LAR or advise you to stop receiving it.

- **slow heart rate (bradycardia).** SIGNIFOR LAR can cause your heart to beat slower. People who have, or have had heart problems, or take certain medicines used to treat slow heart rate or that may cause a slow heart rate, are at higher risk for bradycardia. Tell your healthcare provider if you get any of these symptoms:
 - weakness
 - dizziness
 - fainting or near fainting spells
- **changes in the electrical system of your heart (QT interval prolongation).** Tell your healthcare provider if you get any of these symptoms:
 - weakness
 - dizziness
 - fainting or near fainting spells
- **higher than normal liver function tests.** Your healthcare provider should do blood tests to check your liver while you receive SIGNIFOR LAR.

- **gallstones (cholelithiasis)**. Tell your healthcare provider if you get any of these symptoms:
 - sudden pain in your upper right stomach area (abdomen)
 - sudden pain in your right shoulder or between your shoulder blades
 - yellowing of your skin and whites of your eyes
 - fever with chills
 - nausea
- **low levels of pituitary hormones (pituitary insufficiency)**. SIGNIFOR LAR may reduce the pituitary hormones in your body. Your healthcare provider should do a blood test to check your pituitary hormone levels before you start receiving SIGNIFOR LAR and while you receive it. Tell your healthcare provider if you get any of these symptoms:
 - nausea and vomiting
 - tiredness
 - dizziness
 - diarrhea
 - low blood glucose levels
 - loss of appetite
 - weight loss

The most common side effects of SIGNIFOR LAR include:

- diarrhea
- gallstones (cholelithiasis)
- high blood sugar (hyperglycemia)
- diabetes mellitus

Tell your healthcare provider if you have any side effect that bothers you or that does not go away.

These are not all the possible side effects of SIGNIFOR LAR. For more information, ask your healthcare provider or pharmacist.

Call your doctor for medical advice about side effects. You may report side effects to FDA at 1–800–FDA–1088.

How should I store SIGNIFOR LAR?

- Store SIGNIFOR LAR in the refrigerator between 36°F to 46°F (2°C to 8°C).
- Take SIGNIFOR LAR out of the refrigerator at least **30 minutes** before you will receive it to allow it to come to room temperature.
- **Do not** use SIGNIFOR LAR if it has been out of the refrigerator and at room temperature for more than 24 hours.
- Your healthcare provider should give you SIGNIFOR LAR right away after it is mixed.

Keep SIGNIFOR LAR and all medicines out of the reach of children.

General information about the safe and effective use of SIGNIFOR LAR.

Medicines are sometimes prescribed for purposes other than those listed in a Patient Information leaflet. Do not use SIGNIFOR LAR for a condition for which it was not prescribed. Do not give SIGNIFOR LAR to other people, even if they have the same symptoms that you have. It may harm them.

This Patient Information leaflet summarizes the most important information about SIGNIFOR LAR. If you would like more information, talk to your healthcare provider. You can ask your pharmacist or healthcare provider for information about SIGNIFOR LAR that is written for health professionals.

For more information go to www.SIGNIFORLAR.com or call 1-888-NOW-NOVA.

What are the ingredients in SIGNIFOR LAR?

Active ingredient: pasireotide

Inactive ingredients:

Vial: Poly(D,L-lactide-co-glycolide)

Prefilled syringe: Mannitol, carboxymethylcellulose sodium, poloxamer 188, water for injections

This Patient Information has been approved by the U.S. Food and Drug Administration.

Distributed by:
Novartis Pharmaceuticals Corporation
East Hanover, NJ 07936

T2016-XX/T2016-XX
Month Year