

HIGHLIGHTS OF PRESCRIBING INFORMATION

These highlights do not include all the information needed to use VARITHENA™ safely and effectively. See full prescribing information for VARITHENA™.

Varithena™ (polidocanol injectable foam), for intravenous use
Initial U.S. Approval: 2013

INDICATIONS AND USAGE

Varithena™ (polidocanol injectable foam) is a sclerosing agent indicated for the treatment of incompetent great saphenous veins, accessory saphenous veins and visible varicosities of the great saphenous vein system above and below the knee. Varithena™ improves the symptoms of superficial venous incompetence and the appearance of visible varicosities. (1)

DOSAGE AND ADMINISTRATION

For intravenous use under ultrasound guidance only. Use up to 5 ml per injection and 15 ml per treatment session (2)
Separate treatments sessions by a minimum of 5 days (2)

DOSAGE FORMS AND STRENGTHS

Injectable foam delivering a 1% polidocanol solution. (3)
Each mL of Varithena™ injectable foam contains 1.3 mg of polidocanol. (3)

CONTRAINDICATIONS

- Known allergy to polidocanol (4)

- Acute thromboembolic disease (4)

WARNINGS AND PRECAUTIONS

- Be prepared to treat anaphylaxis. (5.1)
- Tissue ischemia and necrosis: Do not inject intra-arterially. (5.2)
- Venous Thrombosis (5.3)

ADVERSE REACTIONS

In clinical trials, the most common related adverse events (occurring in $\geq 3\%$ of patients treated with Varithena™) were pain/discomfort in extremity, infusion site thrombosis (retained coagulum), injection site hematoma or pain, thrombophlebitis superficial, and extravasation.(6.1)

To report SUSPECTED ADVERSE REACTIONS, contact Biocompatibles Inc. at 1-855-971-VEIN or FDA at 1-800-FDA-1088 or www.fda.gov/medwatch.

DRUG INTERACTIONS

There are no known drug interactions with Varithena™. (7)

USE IN SPECIFIC POPULATIONS

Do not use Varithena in pregnant women. (8.1)

See 17 for PATIENT COUNSELING INFORMATION

Revised: 11/2013

FULL PRESCRIBING INFORMATION: CONTENTS*

1	INDICATIONS AND USAGE
2	DOSAGE AND ADMINISTRATION
3	DOSAGE FORMS AND STRENGTHS
4	CONTRAINDICATIONS
5	WARNINGS AND PRECAUTIONS
5.1	Anaphylaxis
5.2	Tissue Ischemia and Necrosis
5.3	Venous Thrombosis
6	ADVERSE REACTIONS
6.1	Clinical Trials Experience
7	DRUG INTERACTIONS
8	USE IN SPECIFIC POPULATIONS
8.1	Pregnancy
8.2	Labor and Delivery
8.3	Nursing Mothers
8.4	Pediatric Use
8.5	Geriatric Use

10	OVERDOSAGE
11	DESCRIPTION
12	CLINICAL PHARMACOLOGY
12.1	Mechanism of Action
12.2	Pharmacodynamics
12.3	Pharmacokinetics
13	NONCLINICAL TOXICOLOGY
13.1	Carcinogenesis, Mutagenesis, Impairment of Fertility
13.2	Animal Toxicology and/or Pharmacology
14	CLINICAL STUDIES
16	HOW SUPPLIED/STORAGE AND HANDLING
16.1	How Supplied
16.2	Storage and Handling
17	PATIENT COUNSELING INFORMATION

*Sections or subsections omitted from the full prescribing information are not listed.

FULL PRESCRIBING INFORMATION

1 INDICATIONS AND USAGE

Varithena™ (polidocanol injectable foam) is indicated for the treatment of incompetent great saphenous veins, accessory saphenous veins and visible varicosities of the great saphenous vein (GSV) system above and below the knee. Varithena™ improves the symptoms of superficial venous incompetence and the appearance of visible varicosities.

2 DOSAGE AND ADMINISTRATION

For intravenous use only.

Varithena™ is intended for intravenous injection using ultrasound guidance, administered via a single cannula into the lumen of the target incompetent trunk veins or by direct injection into varicosities. Use up to 5 ml per injection and no more than 15 mL per session.

Physicians administering Varithena™ must be experienced with venous procedures, possess a detailed working knowledge of the use of the duplex ultrasound in venous disease and be trained in the administration of Varithena™.

Activate Varithena™ using the Varithena™ Oxygen Canister and Polidocanol Canister (*see Instructions for Use*). Once a Varithena™ Transfer Unit is in place, foam can be generated and transferred to a syringe. Discard the syringe contents if there are any visible bubbles. Administer the injectable foam within 75 seconds of extraction from the canister to maintain injectable foam properties. Use a new sterile syringe after each injection. Use a new Varithena™ Transfer Unit for each treatment session.

Local anesthetic may be administered prior to cannula insertion but neither tumescent anesthesia nor patient sedation is required. Cannulate the vein to be treated using ultrasound guidance to confirm venous access.

Inject freshly generated Varithena™ slowly (approximately 1 mL/second in the GSV and 0.5 mL/second in accessory veins or varicosities) while monitoring using ultrasound. Confirm venospasm of the treated vein using ultrasound.

When treating the proximal GSV, stop the injection when Varithena™ is 3-5 cm distal to the Saphenofemoral Junction (SFJ).

Apply compression bandaging and stockings and have the patient walk for at least 10 minutes, while being monitored. Maintain compression for 2 weeks after treatment.

Repeat treatment may be necessary if the size and extent of the veins to be treated require more than 15 mL of Varithena™. Separate treatment sessions by a minimum of 5 days.

Retained coagulum may be removed by aspiration (microthrombectomy) to improve comfort and reduce skin staining.

3 DOSAGE FORMS AND STRENGTHS

Polidocanol Solution, 180 mg/18 mL (10 mg/mL) must be activated before use.

Once activated, Varithena is a white, injectable foam delivering a 1% polidocanol solution. Each mL of Varithena™ injectable foam contains 1.3 mg of polidocanol.

4 CONTRAINDICATIONS

The use of Varithena™ is contraindicated in patients with:

- known allergy to polidocanol [*see Warnings and Precautions (5.1)*]
- acute thromboembolic disease

5 WARNINGS AND PRECAUTIONS

5.1 Anaphylaxis

Severe allergic reactions have been reported following administration of liquid polidocanol, including anaphylactic reactions, some of them fatal. Observe patients for at least 10 minutes following injection and be prepared to treat anaphylaxis appropriately.

5.2 Tissue Ischemia and Necrosis

Intra-arterial injection or extravasation of polidocanol can cause severe necrosis, ischemia or gangrene. Patients with underlying arterial disease, such as marked peripheral arteriosclerosis or thromboangiitis obliterans (Buerger's Disease) may be at increased risk for tissue ischemia. If intra-arterial injection of polidocanol occurs, consult a vascular surgeon immediately.

5.3 Venous Thrombosis

Varithena™ can cause venous thrombosis [*see Adverse Reactions (6)*]. Follow administration instructions closely and monitor for signs of venous thrombosis after treatment. Patients with reduced mobility, history of deep vein thrombosis or pulmonary embolism, or recent (within 3 months) major surgery, prolonged hospitalization or pregnancy are at increased risk for developing thrombosis.

6 ADVERSE REACTIONS

6.1 Clinical Trials Experience

Because clinical trials are conducted under controlled but widely varying conditions, adverse reaction rates observed in clinical trials of Varithena™ cannot be directly compared to rates in the clinical trials of other drugs or procedures and may not reflect the rates observed in practice.

A total of 1333 patients in 12 clinical trials were evaluated for safety when treated with Varithena™ at dose concentrations of 0.125%, 0.5%, 1.0% or 2.0%, including 437 patients treated with Varithena™ in placebo-controlled clinical trials.

Adverse reactions occurring in 3% more patients receiving Varithena™ 1% than receiving placebo are shown in [Table 1](#).

Table 1: Treatment-emergent adverse reactions (3% more on Varithena™ 1% than on placebo) through Week 8 (n=588)

Adverse Reaction	Placebo (N=151)	Varithena™ 1.0% (N=149)	Pooled ^a Varithena™ (N=437)
Pain in extremity	14 (9.3)	25 (16.8)	65 (14.9)
Infusion site thrombosis ^b	0	24 (16.1)	46 (10.5)
Contusion/injection site hematoma	9 (6.0)	23 (15.4)	38 (8.7)
Limb discomfort	5 (3.3)	18 (12.1)	32 (7.3)
Tenderness/injection site pain	5 (3.3)	16 (10.7)	30 (6.9)
Venous thrombosis limb ^c	0	12 (8.1)	24 (5.5)
Thrombophlebitis superficial	2 (1.3)	8 (5.4)	40 (9.2)
Deep vein thrombosis	0	7 (4.7)	10 (2.3)

^a Includes Varithena™ 0.125%, 0.5%, 1.0%, and 2.0% from the placebo-controlled trials.

^b Retained coagulum.

^c Common femoral vein thrombus extension (non-occlusive thrombi starting in the superficial vein and extending into the common femoral vein).

In Varithena™-treated patients, 80% of pain events in the treated extremity resolved within 1 week.

In the 1333 patients treated with Varithena™, the following venous thrombus adverse events occurred: common femoral vein thrombus extension (2.9%), proximal deep vein thrombosis (DVT) (1.7%), distal DVT (1.1%), isolated gastrocnemius and soleal vein thrombosis (1.4%).

Proximal symptomatic venous thrombi occurred in 0.9% of patients treated with Varithena™ 49% (n=35) of these patients required treatment with anticoagulants.

Since Varithena™ induces thrombosis in the treated superficial veins, D-dimer is commonly elevated post-treatment and is not useful diagnostically to assess patients for venous thrombus following treatment with Varithena™.

Neurologic adverse events (cerebrovascular accident, migraines) have been reported in patients following administration of physician compounded foam sclerosants. None of the 1333 patients in the Varithena™ trials experienced clinically important neurological or visual adverse events suggestive of cerebral gas embolism. The incidence of neurologic and visual adverse events within 1 day of treatment in the placebo-controlled studies was 2.7% in the pooled Varithena™ group and 4.0% in the placebo groups.

Skin discoloration adverse events were reported in 1.1% of the pooled Varithena™ group and 0.7% of the placebo group in the placebo-controlled studies.

7 DRUG INTERACTIONS

No specific drug interaction studies have been performed. There are no known drug interactions with Varithena™.

8 USE IN SPECIFIC POPULATIONS

8.1 Pregnancy

Pregnancy Category C.

There are no adequate and well-controlled studies of Varithena™ in pregnant women. Do not use Varithena™ during pregnancy.

Animal Studies

Developmental reproductive toxicity testing was performed in rats and rabbits using intravenous administration of polidocanol solution. In rabbits, dose levels up to and including 10 mg/kg/day (approximately 12 times the proposed maximum human dose of 15 mL of 1% Varithena™ based on body surface area) did not produce any indication of adverse effects on embryo-fetal mortality, fetal weight or the incidences of fetal abnormalities and variants. In rats administered 27 mg/kg/day of polidocanol solution (approximately 13.5 times the human dose based on body surface area), there were no adverse effects on pregnancy performance or fetal development. In a peri- and post-natal study in rats, dose levels of polidocanol up to 9 mg/kg/day (approximately 4.5 times the human dose based on body surface area) were without effects on the development of the conceptus and offspring, and at a dose level of 27 mg/kg/day of polidocanol solution (approximately 13.5 times the human dose based on body surface area), effects were confined to an equivocal reduction in body weights of first-generation males, and an associated equivocal delay in the age of preputial separation.

8.2 Labor and Delivery

The effects of Varithena™ on labor and delivery in pregnant women are unknown.

8.3 Nursing Mothers

It is not known whether polidocanol, the active pharmaceutical ingredient in Varithena™, is excreted in human milk. Because many drugs are excreted in human milk and because of the potential for serious adverse reactions in nursing infants, avoid administering Varithena™ to a nursing woman.

8.4 Pediatric Use

Safety and effectiveness in pediatric patients have not been established.

8.5 Geriatric Use

Of the 1333 subjects in clinical studies treated with Varithena™, 9.1% (n=121) were ≥65 years of age. No clinically important differences in safety or efficacy were observed between older and younger patients in all studies.

10 OVERDOSAGE

There are no known cases of overdosage with Varithena™. In clinical studies, total volumes of up to 60 mL of Varithena™ per treatment session have been administered.

11 DESCRIPTION

Varithena™ injectable foam contains the sclerosant, polidocanol. It is intended for intravenous use only.

Chemically, polidocanol is polyoxyl lauryl ether. The structural formula is represented below:

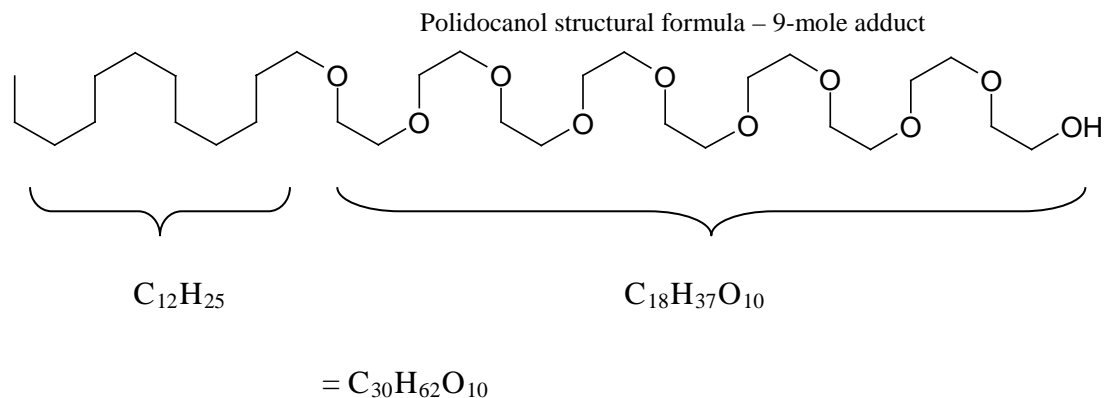

Polidocanol has the molecular formula $CH_3(CH_2)_{11}(OCH_2CH)_nOH$ and molecular weight 582.9 when the average ethylene glycol moieties is nine ($n = 9$). Polidocanol is a white to almost white, waxy, hygroscopic solid that is soluble in water and alcohol and melts at temperatures above 20°C.

Varithena™ is a sterile, injectable foam of an aqueous polidocanol solution (1%) containing the following inactive ingredients: ethanol (4.2% w/w), disodium hydrogen phosphate dihydrate (0.24% w/w), and potassium dihydrogen phosphate (0.085% w/w) with pH adjustment using 0.1 M sodium hydroxide solution and 0.1 M hydrochloric acid solution to achieve a pH of 6.0-7.5.

Activate the Varithena canister to enable foam generation from polidocanol solution, 180 mg/18 mL (10 mg/mL). Once activated, Varithena is a white, injectable foam delivering a 1% polidocanol solution. Each mL of Varithena™ injectable foam contains 1.3 mg of polidocanol. An activated canister of Varithena™ generates 90 mL of injectable foam which, following purging instructions contained in the IFU, is sufficient to yield 45 mL of usable injectable foam for intravenous injection. The polidocanol solution is stored under a carbon dioxide atmosphere in an aluminum canister prior to use.

The injectable foam is generated after activation of the polidocanol canister with oxygen from a second aluminum canister, resulting in a final gas mixture of oxygen:carbon dioxide in a ratio of 65:35 with low (<0.8%) nitrogen content. At the time of use, Varithena™ is generated as an injectable foam of controlled density and bubble size. The foam is then transferred to a syringe through the Varithena™ Transfer Unit. The injectable foam has a liquid to gas ratio of approximately 1:7 by volume. The median bubble diameter is less than 100 µm and no bubbles are greater than 500 µm.

12 CLINICAL PHARMACOLOGY

12.1 Mechanism of Action

Varithena™ is drug/device combination product that generates injectable foam. The injectable foam is composed of a liquid and gas phase, both of which are necessary to have its therapeutic effect.

Varithena™ is intended to act as follows: (1) the foam displaces blood from the vein to be treated, (2) the polidocanol then scleroses the endothelium.

The active pharmaceutical ingredient of Varithena™ is polidocanol, a non-ionic surfactant sclerosing agent. The hydrophobic pole of the polidocanol molecule attaches to the lipid cell membrane of the venous endothelium, resulting in disruption of the osmotic barrier, destruction of the venous endothelium, and vasospasm. Following exposure to polidocanol, the interior surface of the vein becomes thrombogenic, which leads to thrombus formation and venous occlusion. The occluded vein is eventually replaced by fibrous connective tissue. Polidocanol is deactivated upon contact with blood, thus limiting the sclerosant action to the endothelium near the site of injection.

12.2 Pharmacodynamics

The active pharmaceutical ingredient in Varithena™ is polidocanol. Polidocanol has a concentration dependent damaging effect on the endothelium of blood vessels.

12.3 Pharmacokinetics

The pharmacokinetics of Varithena™ (as a weighted sum of 4 oligomers: E5, E9, E12 and E14) were evaluated at two concentrations (1% and 2%) randomly assigned within gender in 20 patients with GSV incompetence.

When administered as an intravenous injectable foam as two fixed 5 mL doses separated by 10 minutes, polidocanol was rapidly detected in plasma, reaching maximum concentration of drug in the body after dosing (C_{max}) within 15 minutes of the first injection and within 5 mins of receiving the second injection of Varithena™ 1% or Varithena™ 2%. The mean volume of distribution (Vd) of polidocanol ranged from 35L to 82L.

Mean systemic clearance (CL) of polidocanol ranged from 0.2 to 0.4 L/min. The clearance of E5 was significantly greater than is that of longer oligomers. Mean terminal elimination half-life ($t_{1/2}$) ranged from 102 to 153 minutes, with most plasma samples below the limit of quantitation (BLQ) at the end of the 8 hour collection period. The increase in plasma polidocanol concentrations was less than proportional with increasing Varithena™ concentration. Weight normalized data demonstrated no consistent differences in C_{max} or AUC between males and females.

13 NONCLINICAL TOXICOLOGY

13.1 Carcinogenesis, Mutagenesis, Impairment of Fertility

Long term studies in animals have not been performed to evaluate carcinogenic potential of Varithena™. No mutagenic activity was observed in the *in vitro* bacterial reverse mutation assay at non-toxic concentrations. No mutagenic activity was observed in the *in vitro* mouse lymphoma assay in the absence of S9 mix and was weakly mutagenic in the presence of S9 close to the limit of acceptance for

the accompanying level of toxicity. No micronucleus induction was detected in the *in vivo* assay on mouse bone marrow cells up to the maximum tolerated dose of 80 mg/kg.

There was no adverse effect on fertility in both male and female rats at 27 mg/kg/day. This dose level is approximately 13.5 times the proposed maximum human dose based on body surface area.

13.2 Animal Toxicology and/or Pharmacology

The pharmacological effects of polidocanol solution on the renal function of the rat were evaluated and at the highest dose tested (10 mg/kg) hematuria occurred in 67% of animals. This dose is 5 times higher than the proposed maximum human dose based on body surface area. Blood was no longer detectable in urine 24 hours after dosing. In the 28 day repeated dose toxicity study in rat blood pigments were noted in the urine for animals in all treatment groups, including male controls, at the end of the 4 week treatment period with up to 27 mg polidocanol/kg/day. Following the 2 week recovery period there was still evidence that blood pigments were present in the urine but the incidence and severity was decreased when compared to the main study animals. There were no histopathological findings in the urinary bladder in any study animals.

In a cardiovascular pharmacology study in the anesthetized dog at 20 mg/kg (approximately 33 times the human dose based on body surface area) statistically significantly higher values for P-Q interval were measured before and during dosing and at all time points up to 30 minutes after dosing. An increase in QRS interval was also measured after dosing of 20 mg/kg and at 5 and 10 minutes after dosing. This effect was short lived and was no longer seen at 15 minutes after dosing. In addition, there was an increase in diastolic pressure with increasing dose of polidocanol. This increase became significantly greater ($p < 0.05$) than baseline before injection of the final and highest dose (20 mg/kg).

In a further cardiovascular pharmacology study conducted with a once weekly, for four weeks, intravenous bolus injection of Varithena™ in the conscious dog, dose levels of up to 8.0 mL/kg (approximately 17 times the human dose based on body surface area) to beagle dogs caused only a transient, but consistent, effect on respiration, evidenced by a decrease in tidal volume and RMV at 15 minutes post-dose, resolving by one hour post-dose. Histopathology of the lung at the end of the 3 month follow-up period showed no abnormalities.

14 CLINICAL STUDIES

Varithena™ was evaluated in two randomized, blinded, multicenter clinical trials designed to assess the efficacy and safety of VARITHENA 0.5%, 1.0% and 2.0% (VANISH-1) and Varithena™ 0.5% and 1.0% (VANISH-2) compared with placebo in the treatment of both symptoms and appearance in patients with SFJ incompetence as evidenced by reflux of the GSV or major accessory veins. In both studies, a Varithena™ 0.125% treatment group was included as a control for blinding of the duplex ultrasound assessment. Patients with history of deep vein thrombosis or pulmonary embolism, inability to comply with post-treatment compression due to severe peripheral arterial disease or leg obesity, incompetence of the small saphenous vein or deep venous reflux as a major source of reflux, or reduced mobility, or major surgery, pregnancy, or prolonged hospitalization within 3 months were excluded. Patients were randomized in an equal distribution to each treatment group; the primary time point for analyses of the primary, secondary and tertiary efficacy endpoints was Week 8.

In these clinical trials, the maximum volume of injectable foam or placebo to be administered per treatment session was 15 mL.

In VANISH-1, patients received one blinded treatment and in VANISH-2, patients received one blinded treatment with an option for a second blinded treatment 1 week later. In VANISH-2, patients in the Varithena™ 1.0% treatment group received an average of 1.4 blinded treatments. All patients received post-procedure compression therapy for 14 days following treatment.

Of the 519 patients randomized into VANISH-1 and VANISH-2, a total of 511 were treated with either Varithena™ 0.5% (n=111), 1.0% (n=110), or 2.0% (n=63), Varithena™ 0.125% as control (n=114), or placebo (n=113). Ninety-nine percent of the patients in VANISH-1 and VANISH-2 completed the blinded treatment period.

In the Varithena™ 1% group in VANISH-2, 23 of 58 patients received an additional blinded treatment. Two of these patients had retreatment of veins treated in the initial treatment session. The remaining 21 patients received treatment for additional veins not treated in the initial treatment session.

The mean age was approximately 50 years and approximately three-fourths of the patients were women. The mean BMI was similar in VANISH-1 and VANISH-2, at 28 kg/m² (range 16 to 44 kg/m²) and 30 kg/m² (range 17 to 48 kg/m²), respectively. The mean baseline GSV diameter was also similar in VANISH-1 and VANISH-2, at 7.6 mm (range 1.5 to 25.9 mm) and 8.7 mm (range 3.1 to 19.4 mm), respectively. Overall, 22% of patients in VANISH-1 and 25% of patients in VANISH-2 reported one or more prior varicose vein procedures in the leg to be treated.

For both clinical trials, the primary efficacy endpoint was improvement in patient symptoms, as measured by the change from baseline to Week 8 in the 7-day average electronic daily diary VVSymQ™ score. The VVSymQ™ score is a patient-reported outcome measure based on daily patient assessment of the varicose vein symptoms determined to be most important to patients: heaviness, achiness, swelling, throbbing, and itching. VVSymQ™ scores range from 0 to 25, where 0 represents no symptoms and 25 represents all 5 symptoms experienced all of the time. Results are shown in Table 2.

For both VANISH-1 and VANISH-2, treatment with 1.0% was superior to placebo in improving symptoms as measured by VVSymQ™, when either a duration or an intensity scale was used to measure patients' symptoms.

Table 2: Improvement in Symptoms of Varicose Veins as Measured by VVSymQ™ at Week 8, VANISH-1 and VANISH-2

	VVSymQ™					
	VANISH-1			VANISH-2		
	Placebo	Varithena™ 1.0%	Pooled Varithena™*	Placebo	Varithena™ 1.0%	Pooled Varithena™*
N	55	50	164	54	57	117
Baseline Score, mean	8.60	8.82	9.23	9.26	7.82	8.67
Adjusted Mean Change from baseline at Week 8	-2.13	-4.87	-5.44	-2.00	-5.06	-5.53

	VVSymQ™					
	VANISH-1			VANISH-2		
	Placebo	Varithena™ 1.0%	Pooled Varithena™*	Placebo	Varithena™ 1.0%	Pooled Varithena™*
Clinically meaningful improvement in Symptoms at Week 8**	5.4% (n=56)	64.7% (n=51)	76.4% (n=165)	19.6% (n=56)	75.9% (n=58)	79.7% (n=118)
Comparison vs. Placebo at Week 8, P-value, Adjusted Mean Change		<0.0001	<0.0001		<0.0001	<0.0001

*VANISH-1 Varithena™ (pooled): 0.5% + 1.0% + 2.0%; VANISH-2 Varithena™ (pooled): 0.5% + 1.0%.

**Percent of patients who reported their symptoms had “moderately improved” or “much improved” compared with baseline.

The co-secondary endpoints in VANISH-1 and VANISH-2 were the improvement in appearance of visible varicosities from baseline to Week 8 as measured by: 1) patients scoring the appearance of their varicose veins in the medial view of their study leg (PA-V³ score) from “Not at all noticeable” (a score of 0) to “Extremely noticeable” (a score of 4); and 2) an independent photography review panel rating the severity of the patient’s varicose vein appearance in standardized digital photographs of the medial view of each patient’s study leg (IPR-V³ score) from “None” (a score of 0) to “Very severe” (a score of 4). Results are shown in [Table 3](#).

Table 3: Improvement in Appearance of Visible Varicosities as Measured by IPR-V³ and PA-V³ at Week 8, VANISH-1 and VANISH-2

	VANISH-1			VANISH-2		
	Placebo	Varithena™ 1.0%	Pooled Varithena™*	Placebo	Varithena™ 1.0%	Pooled Varithena™*
IPR-V³						
n	55	49	161	56	57	117
Baseline Score, mean	1.82	1.98	2.07	2.18	2.02	2.11
Adjusted mean change from baseline at Week 8	-0.01	-0.76	-0.81	-0.07	-0.83	-0.86
Clinically meaningful improvement in Appearance at Week 8†	8.9% (n=56)	70.6% (n=51)	79.4% (n=165)	0 (n=56)	70.7% (n=58)	72.9% (n=118)
Comparison vs. Placebo, P-value at Week 8, Adjusted Mean Change		<0.0001	<0.0001		<0.0001	<0.0001

	VANISH-1			VANISH-2		
	Placebo	Varithena™ 1.0%	Pooled Varithena™*	Placebo	Varithena™ 1.0%	Pooled Varithena™*
PA-V³						
N	55	50	164	56	57	117
Baseline Score, mean	3.49	3.46	3.54	3.30	3.49	3.54
Adjusted mean change from baseline at Week 8	-0.15	-1.60	-1.58	-0.32	-1.79	-1.82
Clinically meaningful improvement in Appearance at Week 8†	3.6% (n=56)	54.9% (n=51)	64.2% (n=165)	7.1% (n=56)	69.0% (n=58)	74.6% (n=118)
Comparison vs. Placebo, <i>P</i> -value at Week 8, Adjusted Mean Change		<0.0001	<0.0001		<0.0001	<0.0001

*VANISH-1 Varithena™ (pooled): 0.5% + 1.0% + 2.0%; VANISH-2 Varithena™ (pooled): 0.5% + 1.0%.

†Percent who reported the appearance of varicose veins had “moderately improved” or “much improved” compared with baseline.

Tertiary endpoints in VANISH-1 and VANISH-2 included response to treatment as determined by change from baseline in Venous Clinical Severity Score (VCSS), by duplex ultrasound, and by change from baseline in Venous Insufficiency Epidemiologic and Economic Study – Quality of Life/Symptoms (VEINES-QOL) score.

VCSS is a clinician rating of severity of chronic venous insufficiency ranging from 0 to 30, where higher scores indicate more severe venous disease. In VANISH-1 and VANISH-2, the adjusted mean changes from baseline in VCSS in the 1% Varithena™ treatment groups were 3.70 and 5.05, respectively, at Week 8 compared with 0.75 and 1.52 points in the placebo groups, respectively. For both studies, the differences between these improvements are statistically significant ($P < 0.0001$).

The physiological response to treatment as measured by duplex ultrasound (duplex response) was defined as elimination of reflux through the SFJ and/or complete occlusion of all incompetent GSV and major accessory veins at baseline. The primary comparison for duplex response in both studies was the pooled Varithena™ groups versus the Varithena™ 0.125% (control) group. Results are shown in [Table 4](#).

Table 4: Response to Treatment as Measured by Duplex Ultrasound at Week 8, VANISH-1 and VANISH-2

Parameter	Treatment Group, %				Comparison of Pooled Varithena™* vs. Varithena™ 0.125% (control)
	Placebo	Varithena™ 0.125% (control)	Varithena™ 1.0%	Pooled Varithena™*	P-value
Responders, VANISH-1**	5.4% (n=56)	42.1% (n=57)	80.4% (n=51)	74.5% (n=165)	<0.0001
Responders, VANISH-2	1.8% (n=56)	59.6% (n=57)	86.2% (n=58)	84.7% (n=118)	0.0002

* VANISH-1 Varithena™ (pooled): 0.5% + 1.0% + 2.0%; VANISH-2 Varithena™ (pooled): 0.5% + 1.0%.

**In VANISH-1, a significant dose-response trend was evident between the percent of responders and the dose concentration of Varithena™ ($P < 0.0001$).

VEINES-QOL is a disease-specific quality of life instrument, ranging from 0 (worst possible quality of life) to 100 (best possible quality of life). In VANISH-1 and VANISH-2, the adjusted mean changes from baseline in VEINES-QOL in the pooled Varithena™ treatment groups were 21.2 and 21.6, respectively, at Week 8 compared with 7.7 and 7.4 points in the placebo groups, respectively. For both studies, the differences between these improvements are statistically significant ($P < 0.0001$).

For efficacy endpoints, Varithena™ treatment effects were consistent across subgroups of age, sex, BMI (up to 48 kg/m²), CEAP clinical class, GSV diameter (up to 25.9 mm) and VCSS.

16 HOW SUPPLIED/STORAGE AND HANDLING

16.1 How Supplied

Varithena™ is supplied in a convenience box (NDC 60635-133-01) that contains:

- A Tyvek pouch containing two sterile, connected 303 mL aluminum alloy canisters: one containing Polidocanol Solution, 180 mg/18 mL (10 mg/mL), under a carbon dioxide atmosphere, the second containing pressurized oxygen at approximately 5.4 bar absolute. The connector joins the two canisters and allows activation of the product. Once activated, Varithena injectable foam delivers a 1% polidocanol solution. Each mL of Varithena injectable foam contains 1.3 mg of polidocanol. One canister of Varithena generates 90 mL of foam which, following purging instructions in the IFU, is sufficient to yield 45 mL of usable foam for injection.
- Three Varithena™ Transfer Units to dispense injectable foam;
- Three administration boxes each containing:
 - Three 10 mL silicone-free Luer syringes;
 - A 20-inch manometer tube;

- Two compression pads.

16.2 Storage and Handling

Do not shake Varithena™ canisters.

Avoid contact with eyes.

Store the Varithena™ convenience box at 68° to 77°F (15° to 25°C); excursions are permitted to between 59° to 86°F (15° and 30°C). Do not refrigerate or freeze.

Unused, non-activated Varithena™ canisters may be stored in the flat or upright position.

Contains gas under pressure: May explode if heated. Store in a well-ventilated place. Store the canisters away from sources of heat including strong light conditions.

Pressurized Oxygen: May cause or intensify fire; oxidizer. Store away from combustible materials.

Once activated, the canister of Varithena™ must be used within seven (7) days.

Store activated canisters of Varithena™ upright, with the Varithena™ Transfer Unit attached, under the same temperature conditions as the Varithena™ convenience box. Use a new Varithena™ Transfer Unit for each treatment session.

Discard aerosol canisters after use in accordance with state and local requirements.

For more information, please refer to the IFU.

17 PATIENT COUNSELING INFORMATION

Advise the patient to keep post-treatment bandages dry and in place for 48 hours and to wear compression stockings on the treated legs continuously for 2 weeks. Compression stockings should be thigh or knee high depending upon the area treated in order to provide adequate coverage. Advise the patient to walk for at least 10 minutes immediately after the procedure and daily for the next month. Following treatment, advise the patient to avoid heavy exercise for 1 week and extended periods of inactivity for 1 month.

If you would like more information, please talk with your doctor. For more information about Varithena™ you can also call us at {1-855-971-VEIN} or go to www.varithena.com.

Manufactured for Provensis Ltd by:

Biocompatibles UK Ltd

Chapman House, Weydon Lane, Farnham, UK, GU9 8QL.



Distributed by:

Biocompatibles, Inc.

115 Hurley Road, Building 3, Oxford, CT 06478

This label may not be the latest approved by FDA.
For current labeling information, please visit <https://www.fda.gov/drugsatfda>

Provensis Ltd, Biocompatibles UK Ltd, and Biocompatibles, Inc. are BTG International group companies

Varithena™ is a trademark of Provensis Ltd

BTG and the BTG roundel logo are registered trademarks of BTG International Ltd

VarithenaTM

(polidocanol foam)

VarithenaTM Delivery System

Instructions for Use

Please read all prescribing information before using the product.

Always write the activation date and time on the canister and verify the product has not expired prior to use.

Once the polidocanol canister has been activated, the shelf-life for the product is seven (7) days.

Rx Only

A canister of VarithenaTM generates 90mL of foam which, following purging instructions contained in this IFU, is sufficient to yield 45mL of usable foam for injection. The gas mix of the foam is 65:35 O₂:CO₂.

WARNINGS:

As the foam fills the syringe and before injecting, inspect the syringe full of foam for any visible bubbles. If there are any present, the foam should be emptied into the VarithenaTM Transfer Unit waste chamber and the syringe refilled.

Do not shake VarithenaTM canisters.

A new VarithenaTM Transfer Unit must be used for each treatment session.

Notes: Use a new sterile syringe after each injection. Never fill a syringe until just before the foam is required.

The activated polidocanol canister should always be stored with a VarithenaTM Transfer Unit in place in the upright position at controlled room temperature.

Foam must be used within 75 seconds of generation.

Unpacking

Gather all the items needed for the generation of foam: the Varithena™ box (including: Varithena™ bi-canister pouch, Varithena™ Transfer Unit, low-silicone syringes, and manometer tubing) (Figure 1a), and the following items that are not supplied: scissors, pen, sterile alcoholic wipes, timer and gloves (Figure 1b).

Open the Varithena™ box containing all the components and remove the box containing the Varithena™ bi-canister pouch. Inspect the pouch and components for damage (discard product if there are any visible signs of damage to pouch or components). Discard the Varithena™ bi-canister box.

Figure 1a

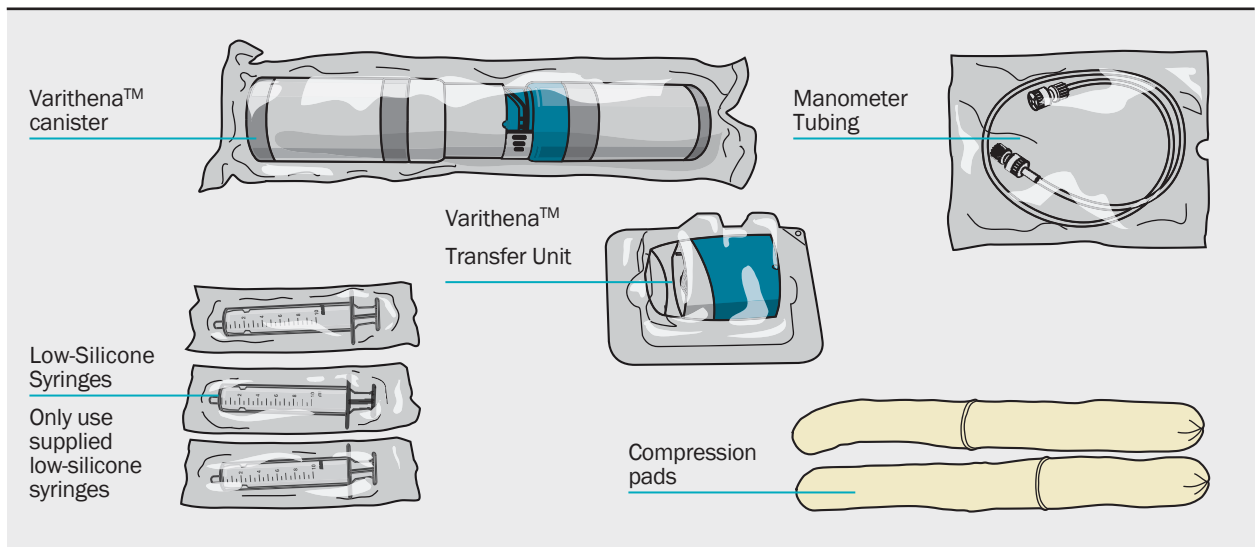
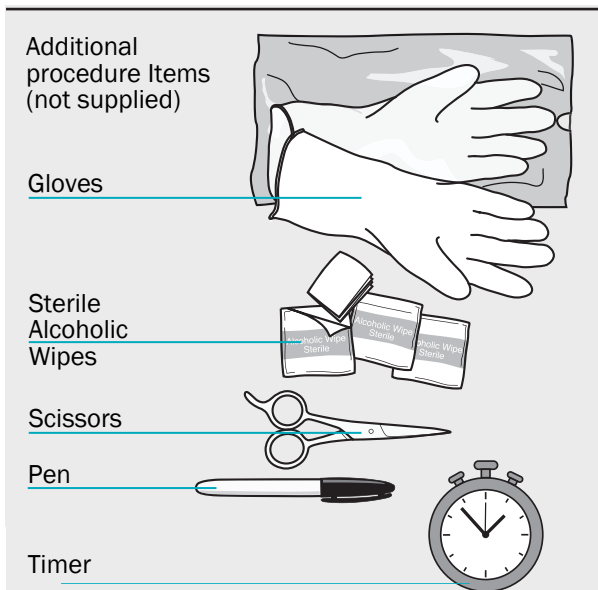

Figure 1b



■ Preparing the Patient

Preparations for treating the patient with Varithena™ should include the following steps:

- Position the patient comfortably on the treatment table in a supine position with their hip externally rotated to facilitate access to the GSV.
- Use ultrasound to find the best site for venous access.
- Using an aseptic technique, infiltrate the skin over the venous access point with local anesthetic.
- Obtain venous access under ultrasound guidance.
- IV catheters that are 16 to 22 gauge and 40- to 50-mm long or micropuncture sets are recommended for venous access.
- Prefill the manometer tube with sterile heparinized normal saline solution and connect to the IV catheter.
- Confirm venous access by aspirating with a syringe, blood should be dark and under low pressure.
- Flush the IV catheter and manometer tube with heparinized normal saline and secure it to the skin with adhesive tape, leave the saline syringe connected.
- With the IV catheter in place and secure, place the patient supine and elevate the leg to approximately 45 degrees.

All preparation of the patient and preparations for Varithena™ injectable foam injection must be completed before generation of the foam.

Varithena™ Preparation

1

Open bi-canister pouch using a pair of scissors. Place canisters upright on a clean stable surface with the white oxygen canister on top (Figure 2). Discard empty pouch.

2

Remove the safety clip by lifting one corner of the clip out (Figure 3). Discard the safety clip.

Figure 2

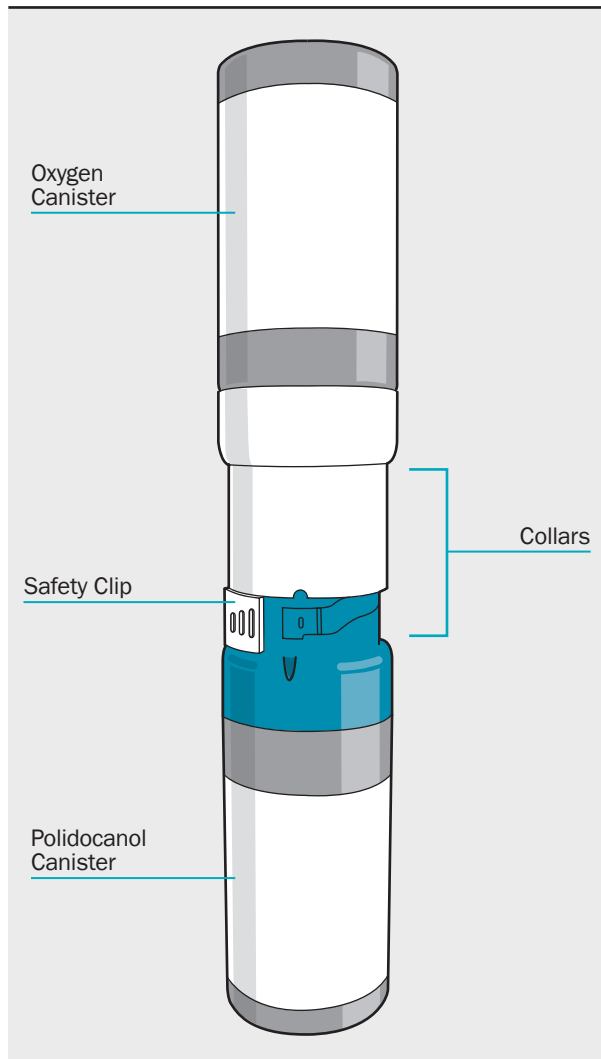
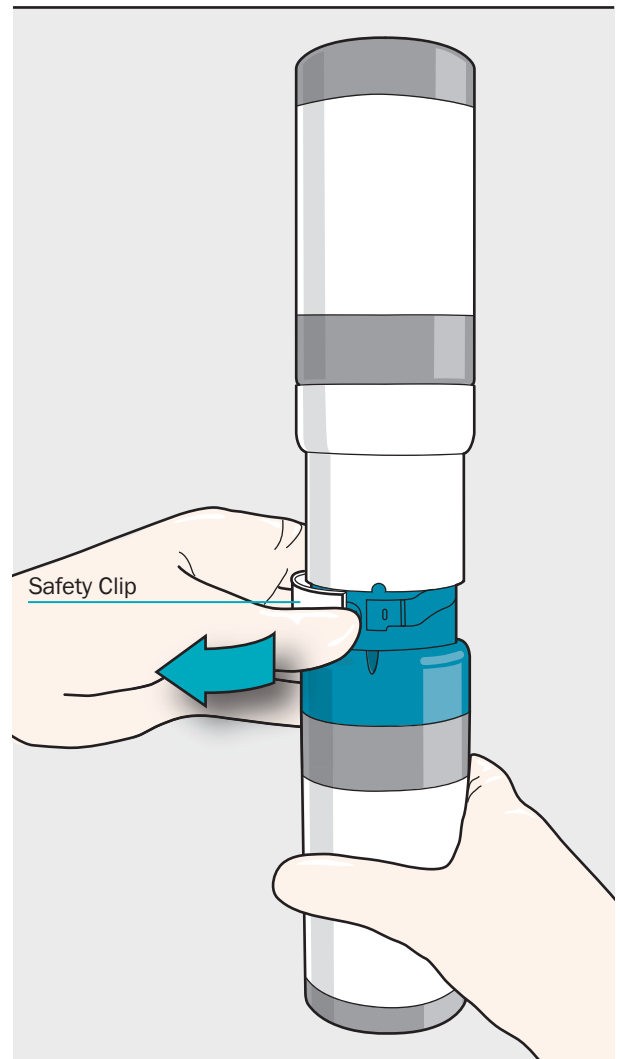

Figure 3



■ Gas Charging of the Varithena™ Canister

3

To begin the gas transfer, twist the canisters together clockwise (Figure 4) until they come to a stop and the small indicators/marks on the collars are aligned (Figure 5). You may hear a bubbling sound.

While the canisters are gassing, keep them upright on a clean flat surface for 1 minute. Use a timing device to keep track of the 1 minute time.

Figure 4

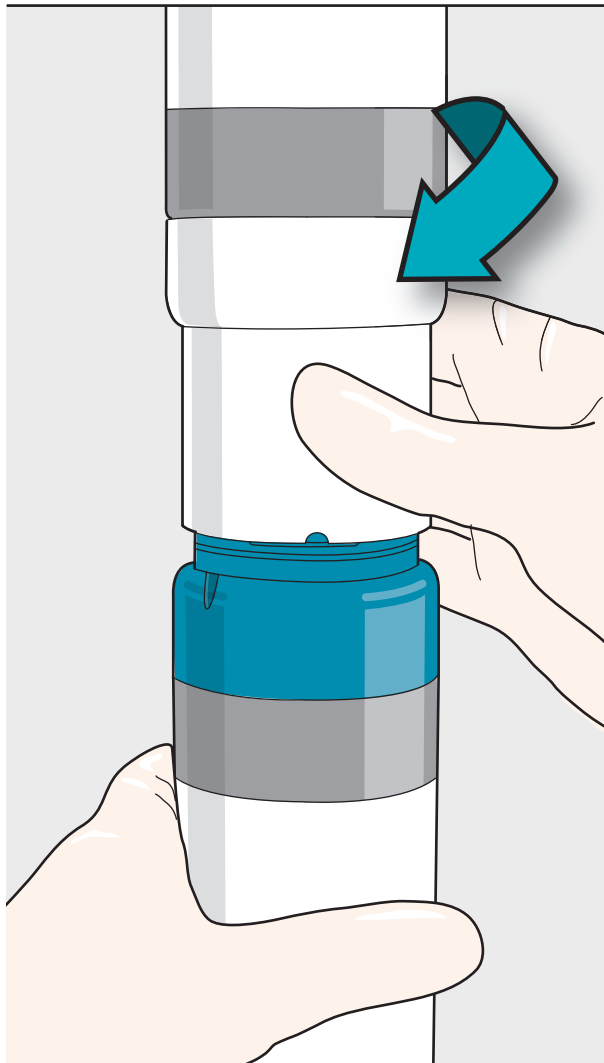
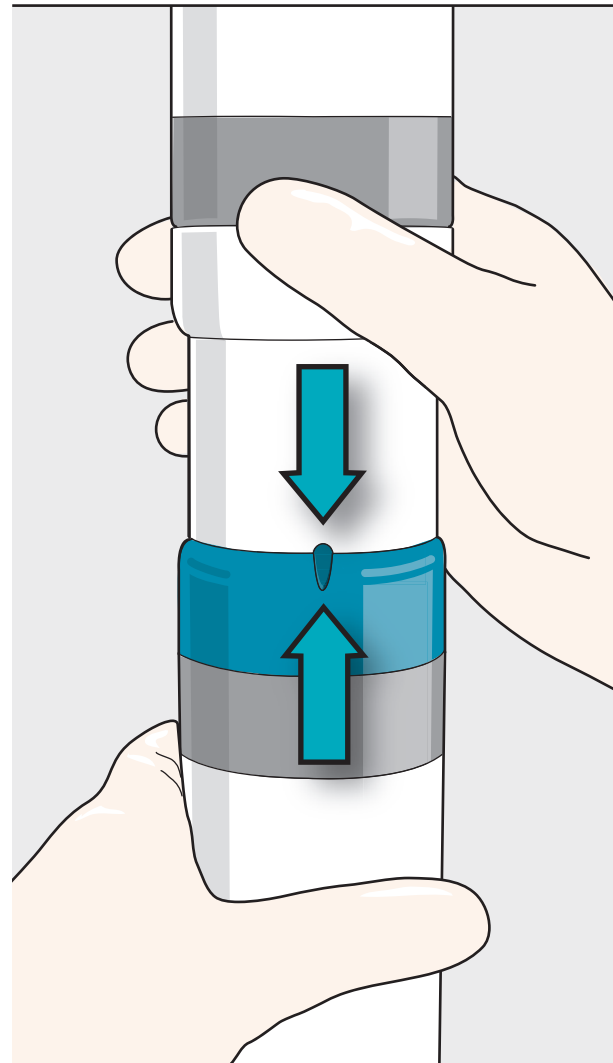

Figure 5



■ Gas Charging of the Varithena™ Canister

4

Note: In order to maintain sterility of the Varithena™ Transfer Unit, the following steps must be followed. While waiting 1 minute for the gas transfer, open a new Varithena™ Transfer Unit, blister pack, but leave the Varithena™ Transfer Unit, in the package (Figure 6).

The manometer tubing (20 inch) should have been previously filled with sterile heparinized normal saline solution.

Figure 6

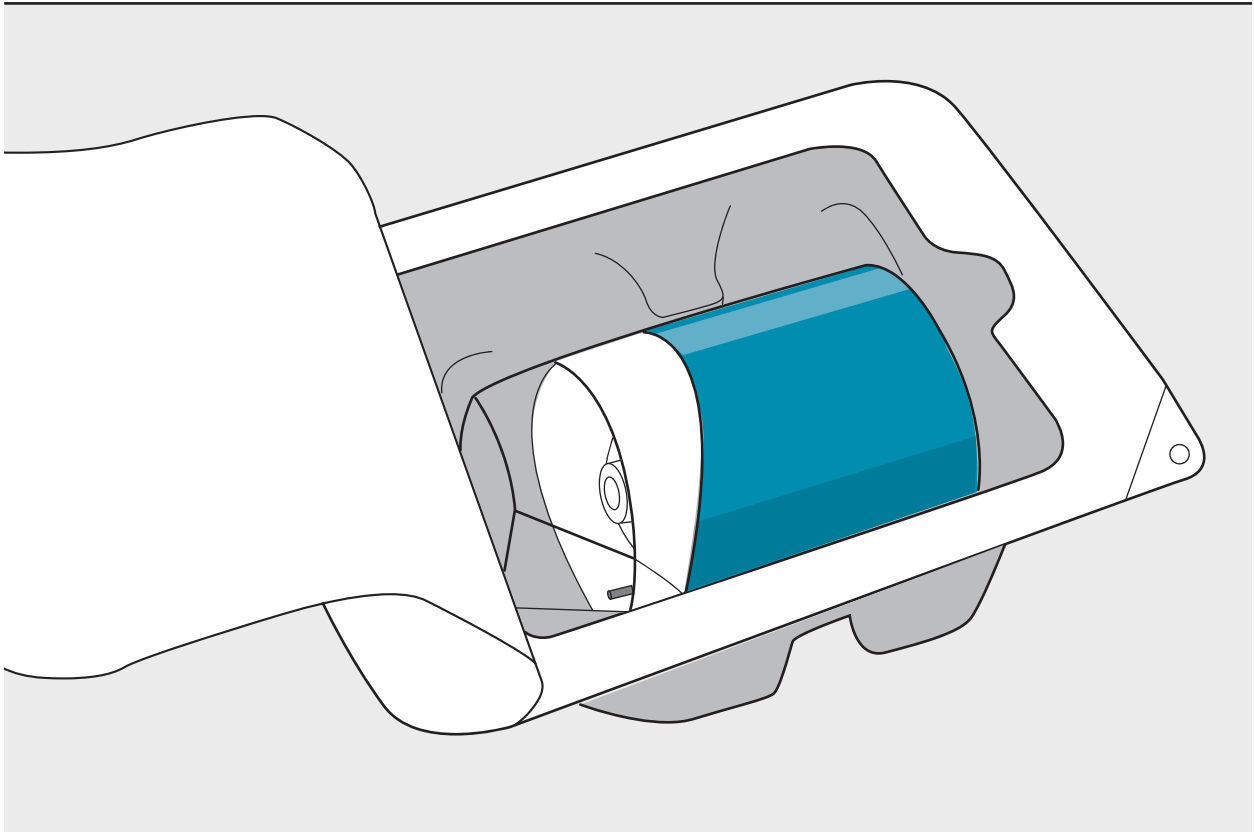

Gas Activating of the Varithena™ Canister

5

After 1 minute,

- Twist the two canisters by turning them in the opposite direction (counterclockwise) as before (Figure 7).
- Pull straight up to separate the oxygen canister from the polidocanol canister, as shown (Figure 8). Do not separate canisters until you have a Varithena™ Transfer Unit ready to place onto the polidocanol canister (See step 6).
- Put the oxygen canister (with white collar) aside.
- The polidocanol canister (with blue collar) should remain on a clean flat surface, in the upright position.

Figure 7

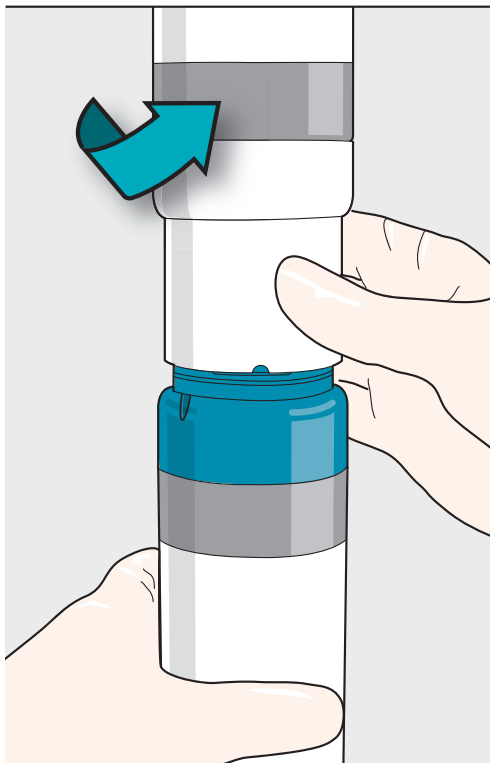
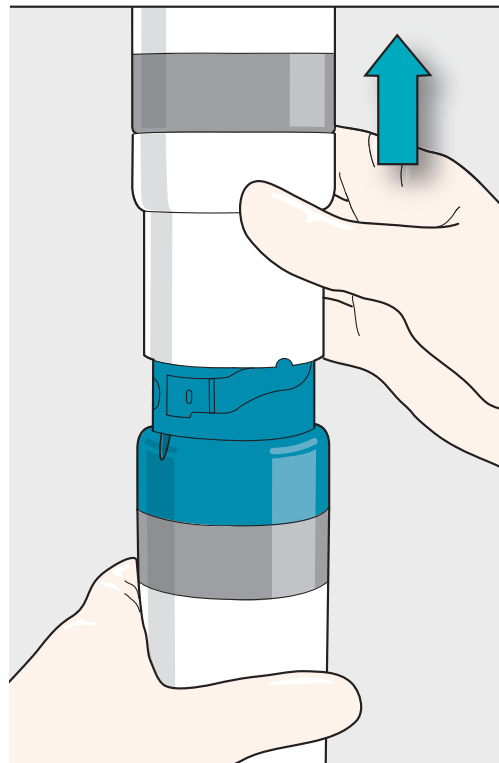

Figure 8



Write today's date and time in the "Date and Time of Activation" box on the Varithena™ canister label (Figure 9).

Figure 9



■ Connecting a new Varithena™ Transfer Unit and Syringe

6

Remove the Varithena™ Transfer Unit from the blister pack. Make sure not to touch the sterile underside of the Varithena™ Transfer Unit, (discard Varithena™ Transfer Unit, if contaminated).

Immediately place the Varithena™ Transfer Unit on top of the blue polidocanol canister. Gently rotate the Varithena™ Transfer Unit clockwise as indicated (Figure 10) until it drops into the collar threads then twist the Varithena™ Transfer Unit (clockwise) until it reaches a stop (Figure 11).

Figure 10

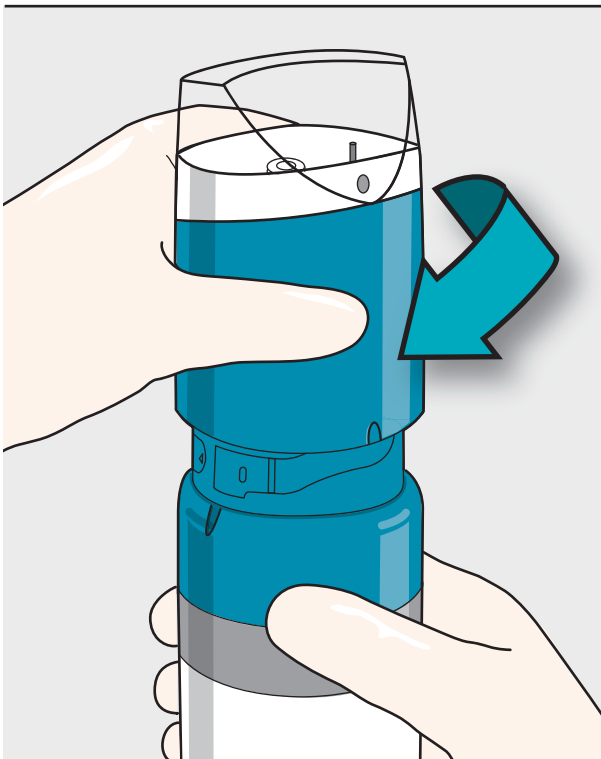
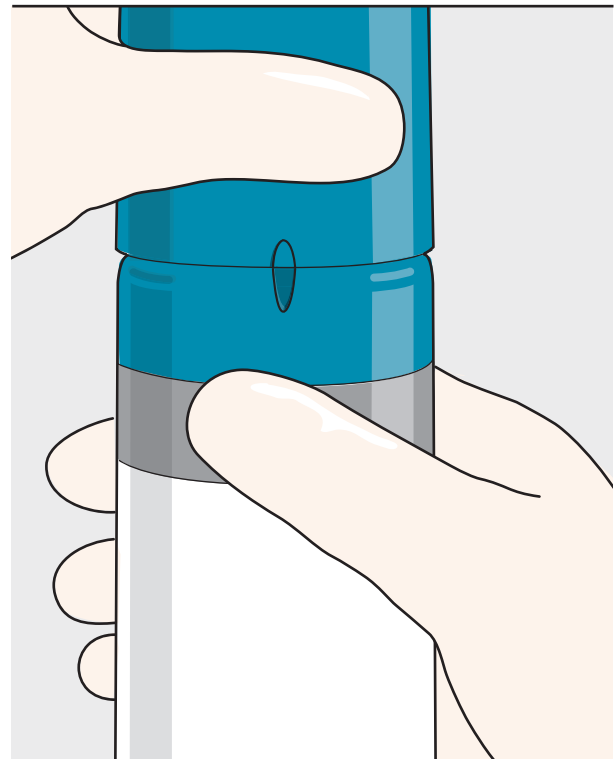

Figure 11



The system is now activated and ready for use.

■ Connecting a new Varithena™ Transfer Unit and Syringe

Change the Varithena™ Transfer Unit immediately before each new treatment session.

Once all preparations for injection are complete, i.e., cannula *in situ*, patient's leg elevated and a good ultrasound view of the saphenofemoral junction (SFJ) obtained, foam may be generated for immediate use.

7

Open a sterile 10mL low-silicone syringe packages and keep it in the package until needed. Remove the syringe from the package, and connect it to the Varithena™ Transfer Unit as shown (Figure 12).

Figure 12

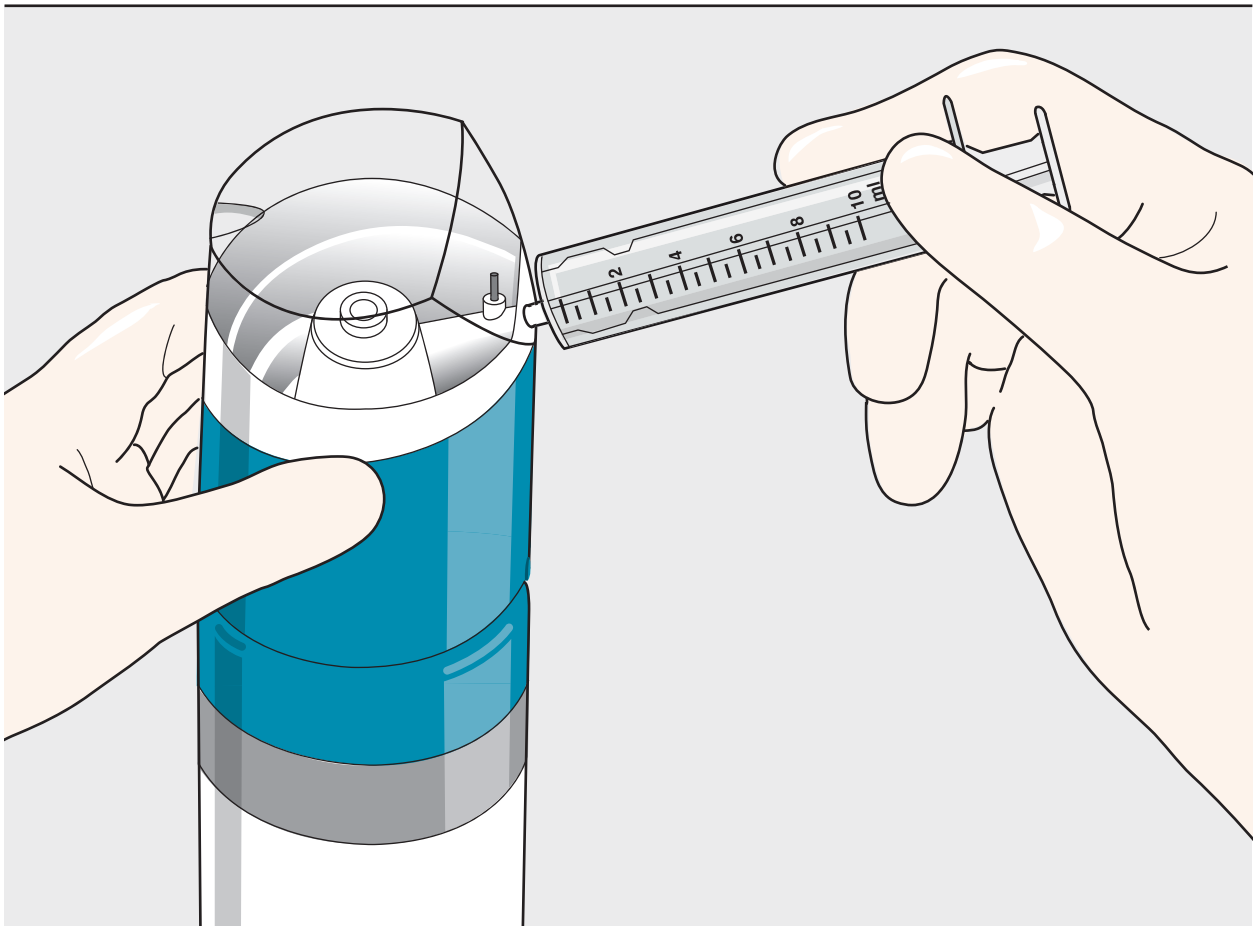

■ Priming a New Syringe

8

Gently press down the Varithena™ Transfer Unit to begin producing foam (Figure 13).

Using continuous pressure, allow the low-silicone syringe to fill between 3mL and 5mL.

Release the pressure on the Varithena™ Transfer Unit and leave the syringe connected.

Figure 13

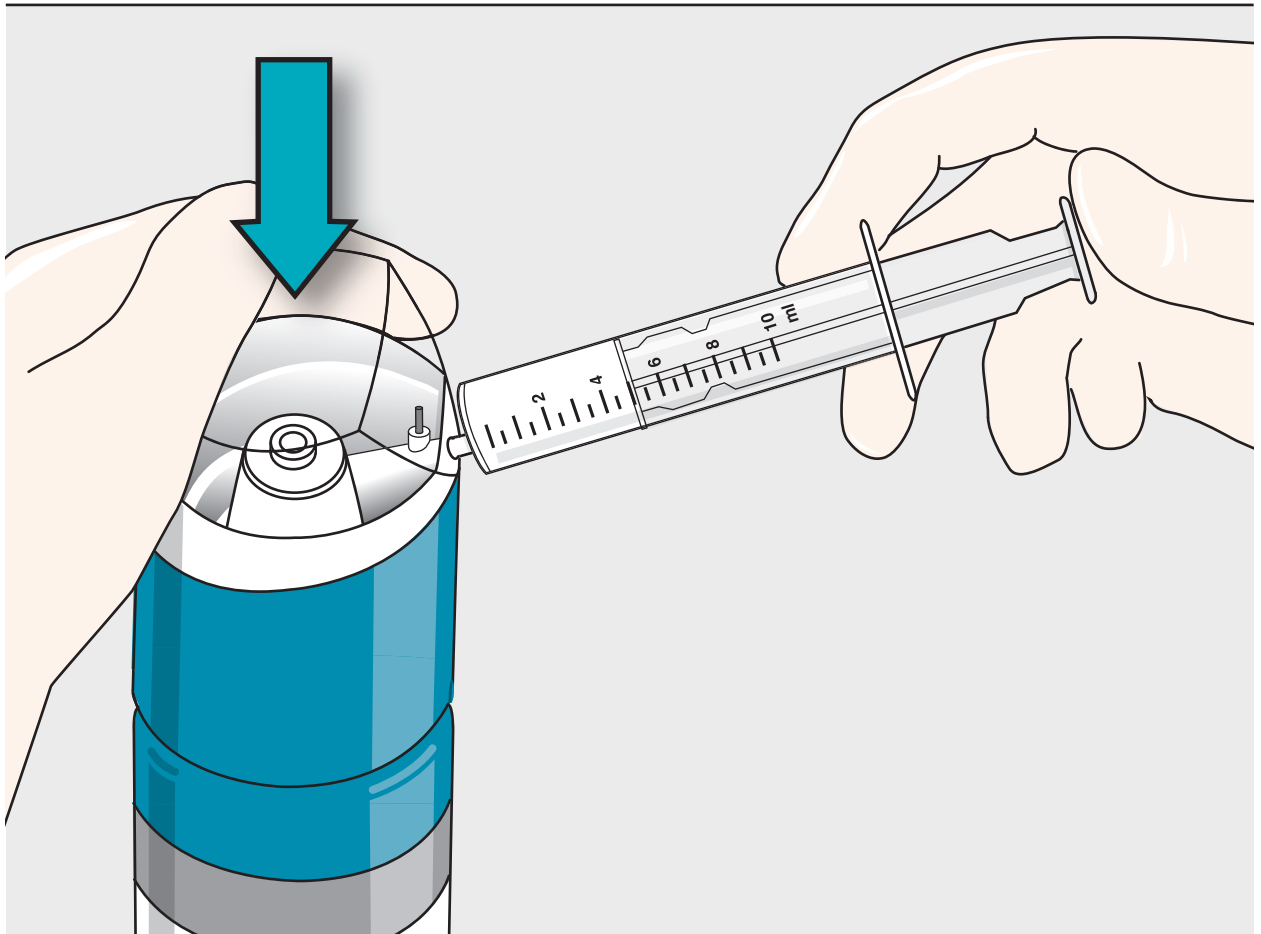

■ Priming a New Syringe

9

Push the low-silicone syringe plunger in fully to discard its contents (Figure 14). Do not disconnect the syringe.

Note: The foam will automatically be diverted into the waste chamber within the Varithena™ Transfer Unit (Figure 15). This process eliminates the small quantity of air in the syringe and Varithena™ Transfer Unit.

Figure 14

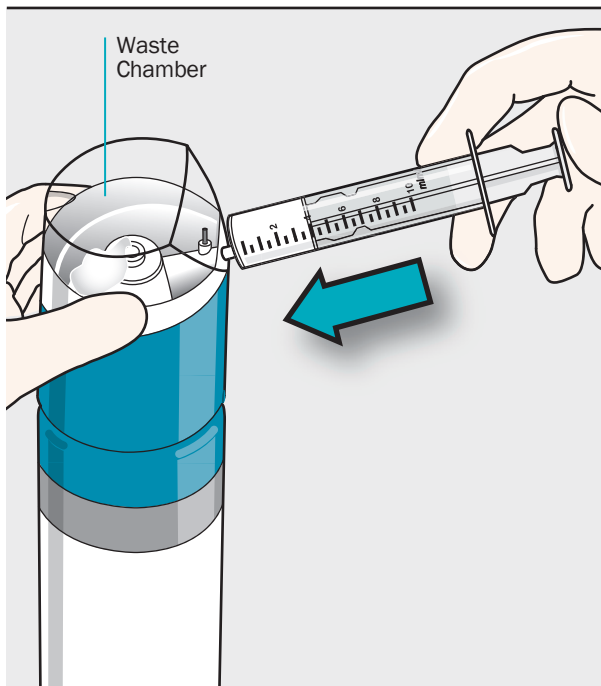
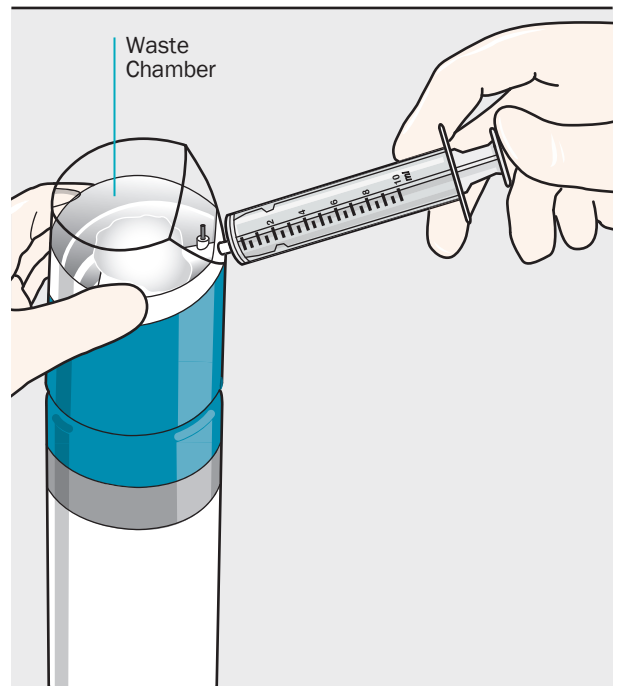

Figure 15



■ Generation of Foam

10

Foam Generation: The technique to produce usable foam requires a single purge cycle before filling the syringe, a process that takes less than 1 second.

Important Note: Foam must be generated by pushing down on the Varithena™ Transfer Unit continuously without pulling back on the plunger of the syringe (aspirating).

While holding the low-silicone syringe plunger in place, gently press down on the Varithena™ Transfer Unit to begin the purge cycle (Figure 16).

Visually inspect the flowing foam inside the Varithena™ Transfer Unit to make sure the visible air bubbles have been expelled (less than 1 second) before releasing the syringe plunger and allowing it to fill to the desired volume (Figure 17).

Draw up to 5mL of foam into the syringe.

Figure 16

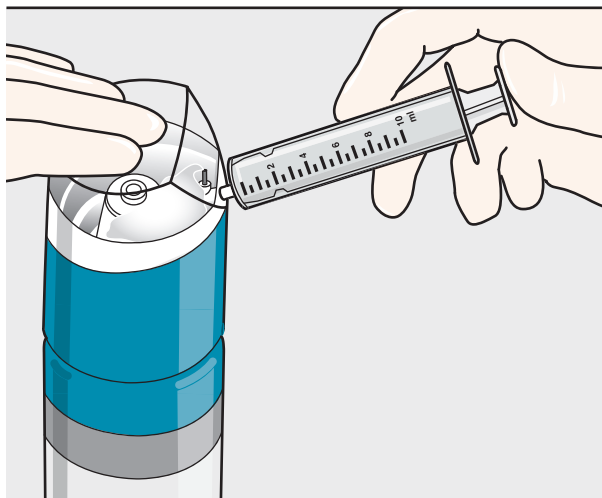
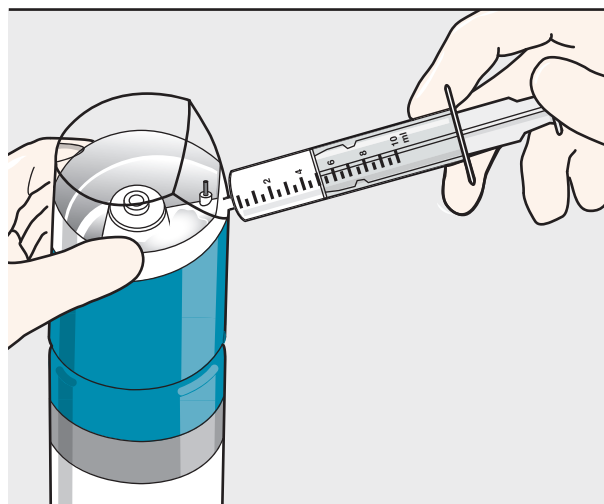

Figure 17



■ Inspecting and Injecting Foam

11

After the low-silicone syringe has filled to the desired volume, **wait 10 seconds** to allow the pressure to equalize before removing the syringe from the Varithena™ Transfer Unit (**Figure 18**).

WARNING: As the foam fills the syringe and before injecting, **inspect the syringe full of foam for any visible bubbles** (easily seen with the unaided eye at arm's length). If there are any present, the foam should be emptied into the Varithena™ Transfer Unit waste chamber and the syringe refilled.

Figure 18

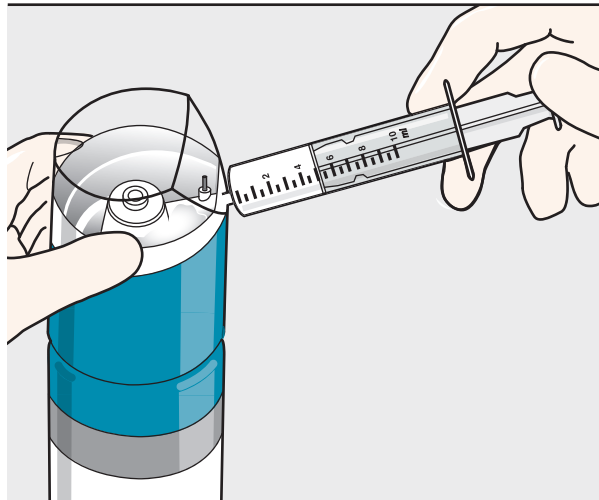

12

Remove the syringe from the Varithena™ Transfer Unit and **inspect it for visible bubbles** (**Figure 19**). If no visible bubbles are present then the foam is ready for use.

Foam must be used within 75 seconds of generation.

WARNING: The total amount of foam injected in any one treatment session must not exceed 15mL, comprised of individual injections of up to 5mL each.

Figure 19

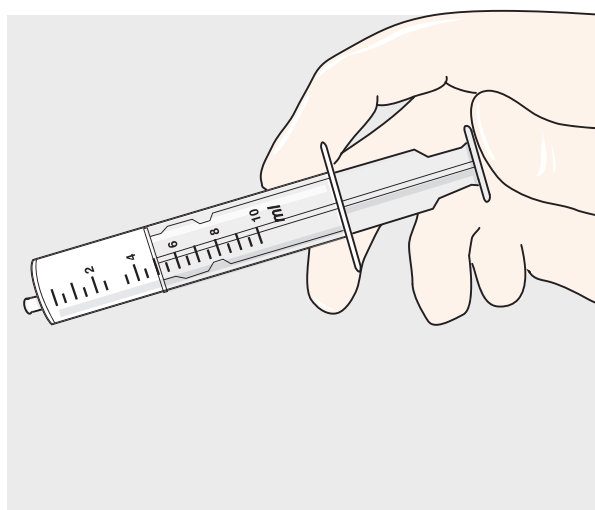

After each treatment session, mark-off on the canister label the number of aliquots of up to 5ml of usable foam drawn from the canister per step 11.

■ Inspecting and Injecting Foam

13

Connect a syringe of freshly generated foam to the manometer tubing, which is already connected to the cannula, in preparation for the initial injection.

The manometer tubing (20 inch) should have been previously filled with sterile heparinized normal saline solution.

14

Inject the foam at approximately 0.5mL to 1.0mL per second through the manometer tubing. Five (5) mLs of foam should be injected in approximately 10 seconds. Always inspect the foam as it passes through the manometer tubing for visible bubbles (Figure 20). If any visible bubbles are seen (easily seen with the unaided eye at arm's length) they should be aspirated back into the low-silicone syringe and the syringe contents discarded back into the Varithena™ Transfer Unit waste chamber, and a fresh syringe of foam generated.

Notes: Use a new sterile syringe after each injection.

Figure 20

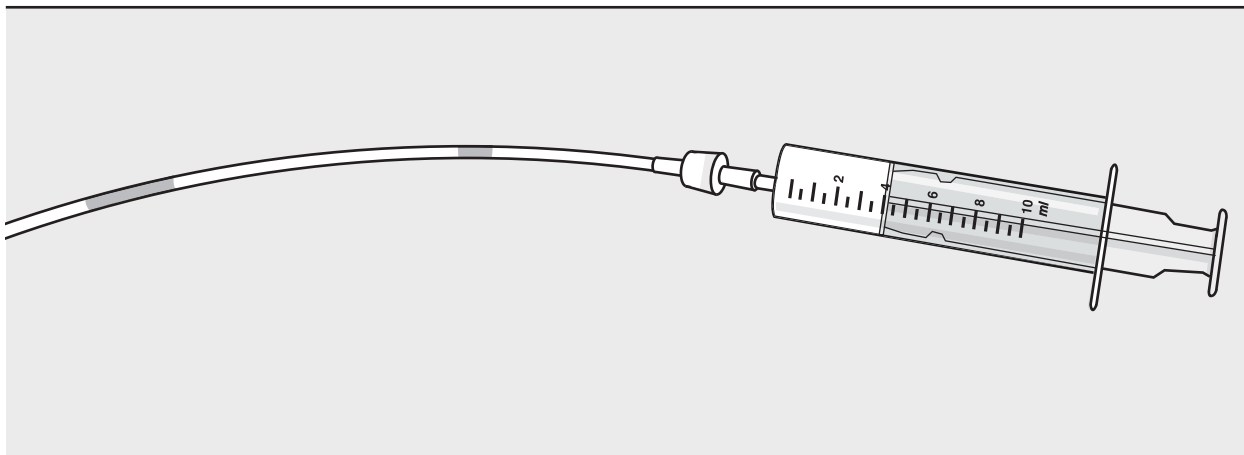

WARNING: The total amount of foam injected in any one treatment session must not exceed 15mL, comprised of individual injections of up to 5mL each

Do not remove the Varithena™ Transfer Unit if the Varithena™ canister is to be stored (see Storage).

■ Replacing the Varithena™ Transfer Unit

Important Note: Do not replace the Varithena™ Transfer Unit if the canister is to be stored for future use. The activated polidocanol canister should always be stored with a Varithena™ Transfer Unit in place in the upright position at controlled room temperature. Replace the Varithena™ Transfer Unit just prior to the next treatment session

15

While holding the Varithena™ canister, twist the Varithena™ Transfer Unit counterclockwise then pull up to separate from the polidocanol canister (Figure 21).

16

Discard the old Varithena™ Transfer Unit and open a new Varithena™ Transfer Unit. Make sure not to touch the sterile underside of the Varithena™ Transfer Unit.

Figure 21

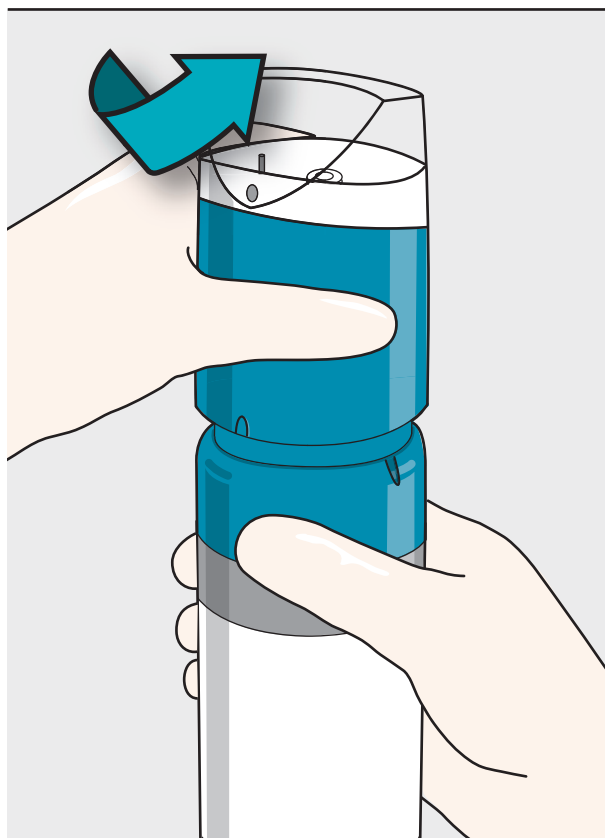

■ Replacing the Varithena™ Transfer Unit

17

Swab the uncovered shuttle with a fresh sterile alcohol wipe (Figure 22) and immediately place the Varithena™ Transfer Unit on top of the Varithena™ canister.

Gently rotate the Varithena™ Transfer Unit clockwise until it drops into the collar threads (Figure 23), then twist the Varithena™ Transfer Unit (clockwise) until it reaches a stop (Figure 24).

Figure 22

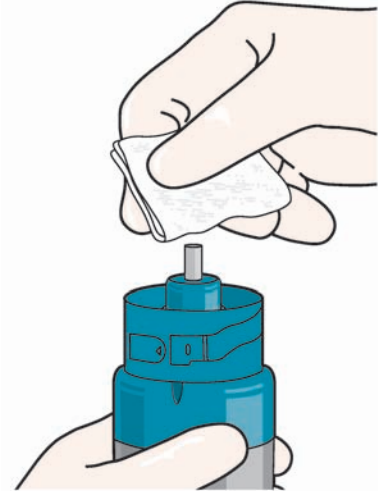

Figure 23

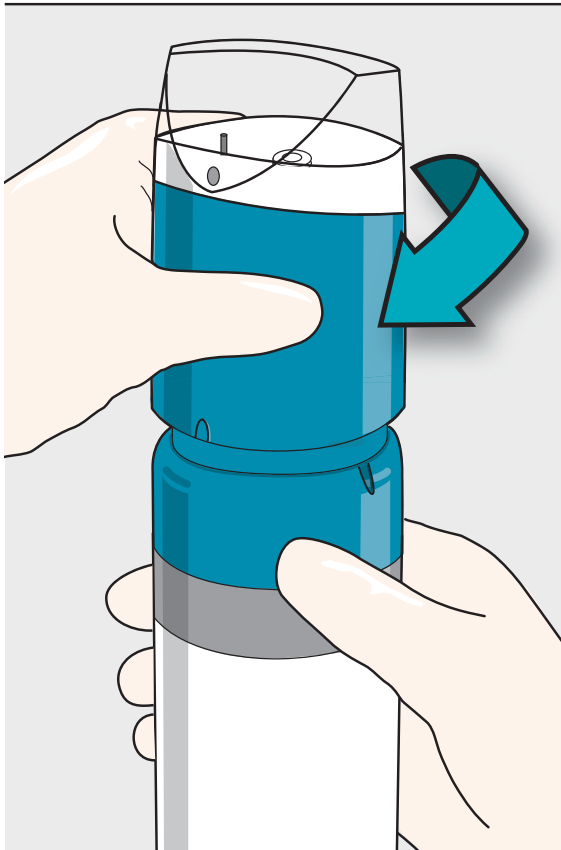
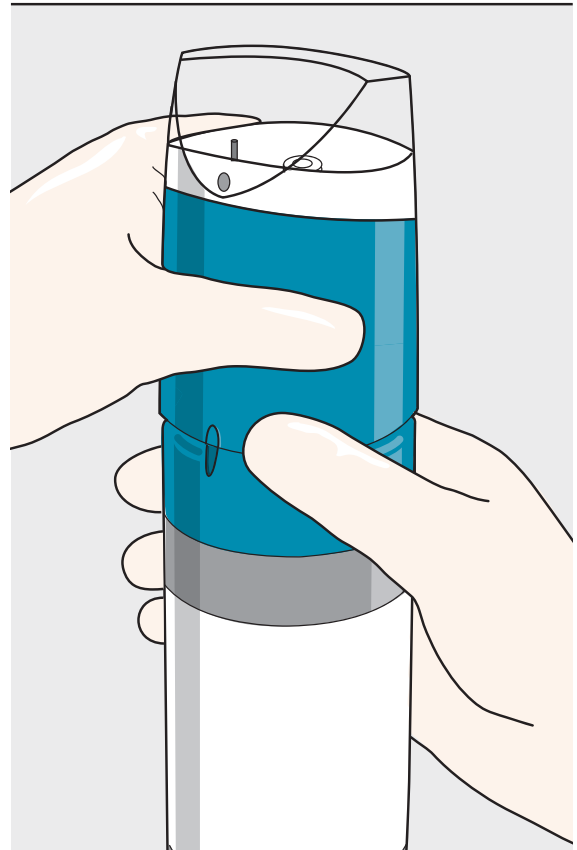

Figure 24



The Varithena™ device now ready for use for a new treatment session.

■ Storage and Disposal

Note: The activated polidocanol canister should always be stored with a Varithena™ Transfer Unit in place in the upright position at controlled room temperature

Once the Varithena™ canister has been activated, the shelf life for the product is seven (7) days.

Always write the activation date and time on the canister and verify the product has not expired prior to use.

Dispose of Varithena™ and oxygen canisters following local and state regulations for aerosol disposal.

The Varithena™ Transfer Unit can be disposed of as non-toxic non-clinical waste.

Net Contents: 18mL

One canister of Varithena™ contains:

180mg Polidocanol, Ethanol 756mg (96%), disodium hydrogen phosphate dihydrate 43.2mg, potassium dihydrogen phosphate 15.3mg, water for injection.

One canister of Varithena™ generates 90mL of foam which, following purging instructions contained in this IFU, is sufficient to yield 45mL of usable foam for injection.
The gas mix of the foam is 65:35 O₂:CO₂.

NDC XXXXX-XXX-XXX

Manufactured for Provensis Ltd by:

Biocompatibles UK Ltd
Chapman House, Weydon Lane, Farnham, Surrey, UK, GU9 8QL

Distributed by:

Biocompatibles, Inc.
115 Hurley Road, Building 3, Oxford, CT 06478

Varithena™ is a trademark of Provensis Ltd
BTG and the BTG roundel logo are registered trademarks of BTG International Ltd

Provensis Ltd, Biocompatibles UK Ltd, and Biocompatibles, Inc., are BTG International group companies

Varithena™
(polidocanol injectable foam)

