

## Front Actuator (nasal spray device) Label

**RiVive™**  
Naloxone HCl Nasal Spray 3 mg  
Emergency Treatment of Opioid Overdose

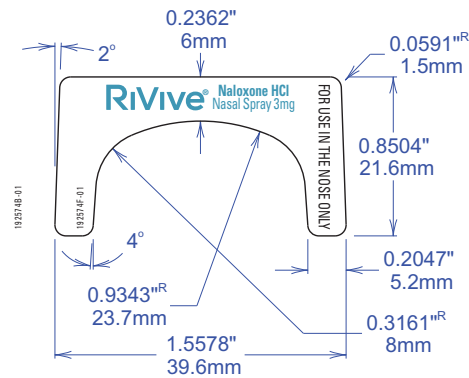

@ Full Size / 100%

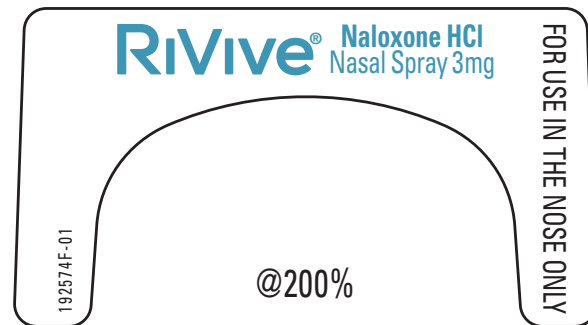

# Back Actuator (nasal spray device) Label

**RiVive™**  
Naloxone HCl Nasal Spray 3 mg  
Emergency Treatment of Opioid Overdose

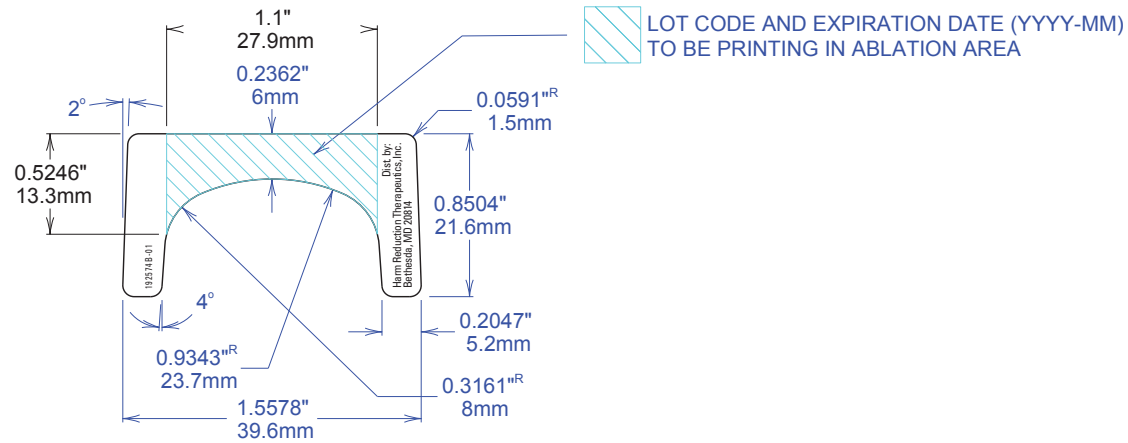

@ Full Size / 100%

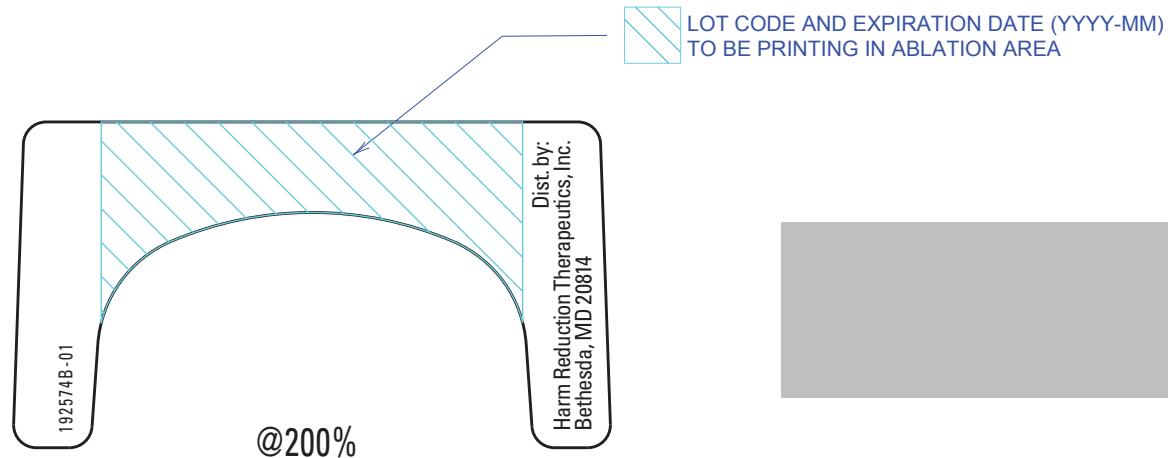

@200%



(b) (4)

# RiVive Blister Card

**RiVive™**  
Naloxone HCl Nasal Spray 3 mg  
Emergency Treatment of Opioid Overdose

PK6006.00

**Pull Corner to Open** →

**RiVive™**  
Naloxone HCl Nasal Spray 3 mg  
Emergency Treatment of Opioid Overdose

- For use in the nose only
- Do not test nasal spray device before use
- 1 nasal spray device contains 1 dose of medicine
- Each device sprays 1 time only

---

- Store at 20°C to 25°C (68°F to 77°F)
- Do not refrigerate
- Avoid excessive heat above 40°C (104°F)

Distributed by:  
Harm Reduction Therapeutics, Inc.  
Bethesda, MD 20814



LOT CODE &  
EXPIRATION DATE (YYYY-MM)  
WILL PRINT IN THIS AREA

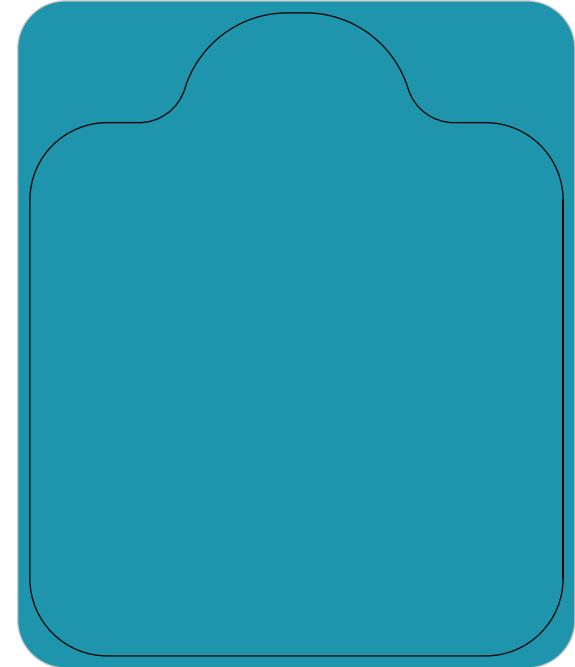

(b) (4)

RiVive Nasal Spray  
Directions (Quick Start Guide)  
**FRONT**  
06.22.23  
RiVive\_Directions\_22JUN23.ai  
(PDF of art being shown is submitted at 100% actual size)

**BACK**

**RiVive™**  
Naloxone HCl Nasal Spray 3 mg  
Emergency Treatment of Opioid Overdose

**DIRECTIONS**

- For use in the nose only
- Do not test nasal spray device before use
- 1 nasal spray device contains 1 dose of medicine
- Each device sprays 1 time only

STEP 1 CHECK LIFE	STEP 2 GIVE	STEP 3 CALL 911	STEP 4 WATCH/GIVE	STEP 5 STAY
<p><b>“WAKE UP!”</b></p>	<p>2-3 minutes</p>	<p>2</p>	<p>2-3 minutes</p>	
<p><b>CHECK</b> if you suspect an overdose</p> <ul style="list-style-type: none"><li>• <b>CHECK</b> for a suspected overdose: the person will not wake up or is very sleepy or not breathing well</li><li>• Yell “Wake up!”</li><li>• Shake the person gently</li><li>• If the person is not awake, go to Step 2</li></ul>	<p><b>GIVE</b> 1<sup>st</sup> dose in the nose</p> <ul style="list-style-type: none"><li>• Hold nasal spray device with thumb on plunger and a finger on each side of the nozzle</li><li>• Insert nozzle into one nostril and press plunger firmly</li><li>• Each nasal spray device contains only one dose of naloxone</li></ul>	<p><b>CALL 911</b></p> <ul style="list-style-type: none"><li>• Get medical help immediately after giving the first dose</li><li>• Call 911 now</li></ul>	<p><b>WATCH/GIVE</b></p> <ul style="list-style-type: none"><li>• <b>WAIT</b> 2-3 minutes after the 1<sup>st</sup> dose to give the medicine time to work</li><li>• If the person <b>wakes up</b>: Go to Step 5</li><li>• If the person does <b>not wake up</b>: Give a second dose of medicine using a new nasal spray device</li><li>• It is safe to keep giving doses every 2-3 minutes until the person wakes up</li></ul>	<p><b>STAY</b></p> <ul style="list-style-type: none"><li>• <b>STAY</b> until ambulance arrives: even if the person wakes up</li><li>• <b>GIVE</b> another dose if the person becomes very sleepy again</li><li>• You may need to give all the doses in the pack</li></ul>

PI6008.00

**HARM REDUCTION THERAPEUTICS**

**Unfold for Directions**

**Unfold for Directions**

2

2

8



RiVive Nasal Spray  
 Carton

06.30.23

RiVive\_CRTN\_30JUN23.ai

(PDF of art being shown is submitted at 100% actual size)

EXPIRATION DATE (YYYY-MM)  
 & LOT CODE

**Drug Facts**

**Active ingredient (in each spray)** Naloxone hydrochloride 3 mg. **Purpose** Emergency treatment of opioid overdose

**Uses**

- to "revive" someone during an overdose from many prescription pain medications or street drugs such as heroin
- this medicine can save a life

**Directions**

**STEP 1 CHECK**

**STEP 2 GIVE**

**STEP 3 CALL 911**

**STEP 4 WATCH/GIVE**

**STEP 5 STAY**

**Step 1: CHECK if you suspect an overdose**

- CHECK** for a suspected overdose: the person will not wake up or is very sleepy or not breathing well
  - "Yell "Wake up!"
  - Shake the person gently
  - If the person is not awake, go to Step 2

**Step 2: GIVE 1<sup>st</sup> dose in the nose**

- Hold nasal spray device with thumb on plunger and a finger on each side of the nozzle
- Insert nozzle into one nostril and press plunger firmly
- Each nasal spray device contains only one dose of naloxone

**Step 3: CALL 911**

- Get medical help **immediately** after giving the first dose
- Call 911 now

**Step 4: WATCH & GIVE**

- WAIT** 2-3 minutes after the 1<sup>st</sup> dose to give the medicine time to work
- If the person **wakes up**: Go to Step 5
- If the person does **not wake up**:
  - Give a **second dose of medicine** using a new nasal spray device
  - It is safe to keep giving doses every 2-3 minutes until the person wakes up

**Step 5: STAY**

- STAY** until ambulance arrives: even if the person wakes up
- GIVE** another dose if the person becomes very sleepy again
- You may need to give all the doses in the pack

NDC 82954-0100-01

**Naloxone HCl Nasal Spray 3 mg**

**CAN SAVE A LIFE**

Read directions before use

Do not test nasal spray device before use

Each device sprays 1 time only

1 nasal spray device contains 1 dose of medicine

**RiVive™**  
 Naloxone HCl Nasal Spray 3 mg

**Emergency Treatment of Opioid Overdose**

**2 Single-Dose Nasal Spray Devices**  
 0.003 fl oz (0.1 mL) each

FOR USE IN THE NOSE

PRESS & TEAR TO OPEN

**Drug Facts (continued)**

**Questions?** For more information call toll-free (888)-412-7434 or go to [www.rivive.com](http://www.rivive.com)

**Drug Facts (continued)**

**Inactive ingredients:** hydrochloric acid, purified water, sodium chloride, sodium hydroxide, triosmium citrate anhydrate

**Other Information**

- do not use if sealed blister package is torn or opened
- do not refrigerate
- do not freeze
- store at 20°C to 25°C (68°F to 77°F)
- avoid excessive heat above 40°C (104°F)

**Warning**

When using this product so no people may experience symptoms when they wake up, such as shivering, sweating, nausea, or feeling dizzy. This is to be expected.

**Drug Facts (continued)**

PK6007.00

HARM REDUCTION THERAPEUTICS  
 Distributed by Harm Reduction Therapeutics, Inc.  
 Bethesda, MD 20814

0 17148 102500 4



-----  
**This is a representation of an electronic record that was signed electronically. Following this are manifestations of any and all electronic signatures for this electronic record.**  
-----

/s/  
-----

NUSHIN F TODD  
07/28/2023 10:51:30 AM