

HIGHLIGHTS OF PRESCRIBING INFORMATION

These highlights do not include all the information needed to use OSVYRTI safely and effectively. See full prescribing information for OSVYRTI.

OSVYRTI (denosumab-desu) injection, for subcutaneous use
Initial U.S. Approval: 2025

OSVYRTI (denosumab-desu) is biosimilar* to PROLIA® (denosumab).

WARNING: SEVERE HYPOCALCEMIA IN PATIENTS WITH ADVANCED KIDNEY DISEASE

See full prescribing information for complete boxed warning.

- Patients with advanced chronic kidney disease are at greater risk of severe hypocalcemia following denosumab products administration. Severe hypocalcemia resulting in hospitalization, life-threatening events and fatal cases have been reported. (5.1)
- The presence of chronic kidney disease-mineral bone disorder (CKD-MBD) markedly increases the risk of hypocalcemia. (5.1)
- Prior to initiating OSVYRTI in patients with advanced chronic kidney disease, evaluate for the presence of CKD-MBD. Treatment with OSVYRTI in these patients should be supervised by a healthcare provider with expertise in the diagnosis and management of CKD-MBD. (2.2, 5.1)

INDICATIONS AND USAGE

OSVYRTI is a RANK ligand (RANKL) inhibitor indicated for treatment:

- of postmenopausal women with osteoporosis at high risk for fracture (1.1)
- to increase bone mass in men with osteoporosis at high risk for fracture (1.2)
- of glucocorticoid-induced osteoporosis in men and women at high risk for fracture (1.3)
- to increase bone mass in men at high risk for fracture receiving androgen deprivation therapy for nonmetastatic prostate cancer (1.4)
- to increase bone mass in women at high risk for fracture receiving adjuvant aromatase inhibitor therapy for breast cancer (1.5)

DOSAGE AND ADMINISTRATION

- Pregnancy must be ruled out prior to administration of OSVYRTI. (2.1)
- Before initiating OSVYRTI in patients with advanced chronic kidney disease, including dialysis patients, evaluate for the presence of chronic kidney disease mineral and bone disorder with intact parathyroid hormone, serum calcium, 25(OH) vitamin D, and 1,25(OH)₂ vitamin D. (2.2, 5.1, 8.6)
- OSVYRTI should be administered by a healthcare provider. (2.3)
- Administer 60 mg every 6 months as a subcutaneous injection in the upper arm, upper thigh, or abdomen. (2.3)
- Instruct patients to take calcium 1000 mg daily and at least 400 IU vitamin D daily. (2.3)

DOSAGE FORMS AND STRENGTHS

- Injection: 60 mg/mL solution in a single-dose prefilled syringe (3)

CONTRAINDICATIONS

- Hypocalcemia (4, 5.1)
- Pregnancy (4, 8.1)
- Known hypersensitivity to denosumab (4, 5.3)

WARNINGS AND PRECAUTIONS

- Hypocalcemia: Pre-existing hypocalcemia must be corrected before initiating OSVYRTI. May worsen, especially in patients with renal impairment. Adequately supplement patients with calcium and vitamin D. Concomitant use of calcimimetic drugs may also worsen hypocalcemia risk. Evaluate for presence of chronic kidney disease mineral-bone disorder. Monitor serum calcium. (5.1)
- Same Active Ingredient: Patients receiving Osvyrti should not receive other denosumab products concomitantly. (5.2)
- Hypersensitivity including anaphylactic reactions may occur.

- Discontinue permanently if a clinically significant reaction occurs. (5.3)
- Osteonecrosis of the jaw: Has been reported with denosumab products. Monitor for symptoms. (5.4)
- Atypical femoral fractures: Have been reported. Evaluate patients with thigh or groin pain to rule out a femoral fracture. (5.5)
- Multiple vertebral fractures have been reported following treatment discontinuation. Patients should be transitioned to another antiresorptive agent if OSVYRTI is discontinued. (5.6)
- Serious infections including skin infections: May occur, including those leading to hospitalization. Advise patients to seek prompt medical attention if they develop signs or symptoms of infection, including cellulitis. (5.7)
- Dermatologic reactions: Dermatitis, rashes, and eczema have been reported. Consider discontinuing OSVYRTI if severe symptoms develop. (5.8)
- Severe bone, joint, muscle pain may occur. Discontinue use if severe symptoms develop. (5.9)
- Suppression of bone turnover: Significant suppression has been demonstrated. Monitor for consequences of bone over-suppression. (5.10)

ADVERSE REACTIONS

- Postmenopausal osteoporosis: Most common adverse reactions (> 5% and more common than placebo) were: back pain, pain in extremity, hypercholesterolemia, musculoskeletal pain, and cystitis. Pancreatitis has been reported in clinical trials. (6.1)
- Male osteoporosis: Most common adverse reactions (> 5% and more common than placebo) were: back pain, arthralgia, and nasopharyngitis. (6.1)
- Glucocorticoid-induced osteoporosis: Most common adverse reactions (> 3% and more common than active-control group) were: back pain, hypertension, bronchitis, and headache. (6.1)
- Bone loss due to hormone ablation for cancer: Most common adverse reactions (≥ 10% and more common than placebo) were: arthralgia and back pain. Pain in extremity and musculoskeletal pain have also been reported in clinical trials. (6.1)

To report SUSPECTED ADVERSE REACTIONS, contact Accord BioPharma Inc. at 1-866-941-7875 or FDA at 1-800-FDA-1088 or www.fda.gov/medwatch.

USE IN SPECIFIC POPULATIONS

- Pregnant women and females of reproductive potential: Denosumab products may cause fetal harm when administered to pregnant women. Advise females of reproductive potential to use effective contraception during therapy, and for at least 5 months after the last dose of OSVYRTI. (8.1, 8.3)
- Pediatric patients: OSVYRTI is not approved for use in pediatric patients. (8.4)
- Renal impairment: No dose adjustment is necessary in patients with renal impairment. Patients with advanced chronic kidney disease (eGFR <30 mL/min/1.73 m²), including dialysis-dependent patients, are at greater risk of severe hypocalcemia. The presence of underlying chronic kidney disease-mineral bone disorder markedly increases the risk of hypocalcemia. (5.1, 8.6)

See 17 for PATIENT COUNSELING INFORMATION and Medication Guide.

*Biosimilar means that the biological product is approved based on data demonstrating that it is highly similar to an FDA-approved biological product, known as a reference product, and that there are no clinically meaningful differences between the biosimilar product and the reference product. Biosimilarity of OSVYRTI has been demonstrated for the condition(s) of use (e.g. indication(s), dosing regimen(s)), strength(s), dosage form(s), and route(s) of administration described in its Full Prescribing Information.

Revised: 10/2025

FULL PRESCRIBING INFORMATION: CONTENTS*

WARNING: SEVERE HYPOCALCEMIA IN PATIENTS WITH ADVANCED KIDNEY DISEASE

1 INDICATIONS AND USAGE

- 1.1 Treatment of Postmenopausal Women with Osteoporosis at High Risk for Fracture
- 1.2 Treatment to Increase Bone Mass in Men with Osteoporosis
- 1.3 Treatment of Glucocorticoid-Induced Osteoporosis
- 1.4 Treatment of Bone Loss in Men Receiving Androgen Deprivation Therapy for Prostate Cancer
- 1.5 Treatment of Bone Loss in Women Receiving Adjuvant Aromatase Inhibitor Therapy for Breast Cancer

2 DOSAGE AND ADMINISTRATION

- 2.1 Pregnancy Testing Prior To Initiation of OSVYRTI
- 2.2 Laboratory Testing in Patients with Advanced Chronic Kidney Disease Prior to Initiation of OSVYRTI
- 2.3 Recommended Dosage
- 2.4 Preparation and Administration

3 DOSAGE FORMS AND STRENGTHS

4 CONTRAINDICATIONS

5 WARNINGS AND PRECAUTIONS

- 5.1 Severe Hypocalcemia and Mineral Metabolism Changes
- 5.2 Drug Products with Same Active Ingredient
- 5.3 Hypersensitivity
- 5.4 Osteonecrosis of the Jaw
- 5.5 Atypical Subtrochanteric and Diaphyseal Femoral Fractures
- 5.6 Multiple Vertebral Fractures (MVF) Following Discontinuation of OSVYRTI Treatment
- 5.7 Serious Infections
- 5.8 Dermatologic Adverse Reactions
- 5.9 Musculoskeletal Pain
- 5.10 Suppression of Bone Turnover
- 5.11 Hypercalcemia in Pediatric Patients with Osteogenesis Imperfecta

6 ADVERSE REACTIONS

- 6.1 Clinical Trials Experience
- 6.2 Postmarketing Experience

8 USE IN SPECIFIC POPULATIONS

- 8.1 Pregnancy
- 8.2 Lactation
- 8.3 Females and Males of Reproductive Potential
- 8.4 Pediatric Use
- 8.5 Geriatric Use
- 8.6 Renal Impairment

11 DESCRIPTION

12 CLINICAL PHARMACOLOGY

- 12.1 Mechanism of Action
- 12.2 Pharmacodynamics
- 12.3 Pharmacokinetics
- 12.6 Immunogenicity

13 NONCLINICAL TOXICOLOGY

- 13.1 Carcinogenesis, Mutagenesis, Impairment of Fertility
- 13.2 Animal Toxicology and/or Pharmacology

14 CLINICAL STUDIES

- 14.1 Treatment of Postmenopausal Women with Osteoporosis
- 14.2 Treatment to Increase Bone Mass in Men with Osteoporosis
- 14.3 Treatment of Glucocorticoid-Induced Osteoporosis
- 14.4 Treatment of Bone Loss in Men with Prostate Cancer
- 14.5 Treatment of Bone Loss in Women with Breast Cancer

16 HOW SUPPLIED/STORAGE AND HANDLING

17 PATIENT COUNSELING INFORMATION

* Sections or subsections omitted from the full prescribing information are not listed.

FULL PRESCRIBING INFORMATION

WARNING: SEVERE HYPOCALCEMIA IN PATIENTS WITH ADVANCED KIDNEY DISEASE

- **Patients with advanced chronic kidney disease (eGFR <30 mL/min/1.73 m²), including dialysis-dependent patients, are at greater risk of severe hypocalcemia following denosumab products administration. Severe hypocalcemia resulting in hospitalization, life-threatening events and fatal cases have been reported [see Warnings and Precautions (5.1)].**
- **The presence of chronic kidney disease-mineral bone disorder (CKD-MBD) markedly increases the risk of hypocalcemia in these patients [see Warnings and Precautions (5.1)].**
- **Prior to initiating OSVYRTI in patients with advanced chronic kidney disease, evaluate for the presence of CKD-MBD. Treatment with OSVYRTI in these patients should be supervised by a healthcare provider with expertise in the diagnosis and management of CKD-MBD [see Dosage and Administration (2.2) and Warnings and Precautions (5.1)].**

1 INDICATIONS AND USAGE

1.1 Treatment of Postmenopausal Women with Osteoporosis at High Risk for Fracture

OSVYRTI is indicated for the treatment of postmenopausal women with osteoporosis at high risk for fracture, defined as a history of osteoporotic fracture, or multiple risk factors for fracture; or patients who have failed or are intolerant to other available osteoporosis therapy. In postmenopausal women with osteoporosis, denosumab reduces the incidence of vertebral, nonvertebral, and hip fractures [see *Clinical Studies (14.1)*].

1.2 Treatment to Increase Bone Mass in Men with Osteoporosis

OSVYRTI is indicated for treatment to increase bone mass in men with osteoporosis at high risk for fracture, defined as a history of osteoporotic fracture, or multiple risk factors for fracture; or patients who have failed or are intolerant to other available osteoporosis therapy [see *Clinical Studies (14.2)*].

1.3 Treatment of Glucocorticoid-Induced Osteoporosis

OSVYRTI is indicated for the treatment of glucocorticoid-induced osteoporosis in men and women at high risk of fracture who are either initiating or continuing systemic glucocorticoids in a daily dosage equivalent to 7.5 mg or greater of prednisone and expected to remain on glucocorticoids for at least 6 months. High risk of fracture is defined as a history of osteoporotic fracture, multiple risk factors for fracture, or patients who have failed or are intolerant to other available osteoporosis therapy [see *Clinical Studies (14.3)*].

1.4 Treatment of Bone Loss in Men Receiving Androgen Deprivation Therapy for Prostate Cancer

OSVYRTI is indicated as a treatment to increase bone mass in men at high risk for fracture receiving androgen deprivation therapy (ADT) for non-metastatic prostate cancer. In these patients denosumab also reduced the incidence of vertebral fractures [see *Clinical Studies (14.4)*].

1.5 Treatment of Bone Loss in Women Receiving Adjuvant Aromatase Inhibitor Therapy for Breast Cancer

OSVYRTI is indicated as a treatment to increase bone mass in women at high risk for fracture receiving adjuvant aromatase inhibitor therapy for breast cancer [see *Clinical Studies (14.5)*].

2 DOSAGE AND ADMINISTRATION

2.1 Pregnancy Testing Prior to Initiation of Ovyrti

Pregnancy must be ruled out prior to administration of OSVYRTI. Perform pregnancy testing in all females of reproductive potential prior to administration of OSVYRTI. Based on findings in animals, denosumab products can cause fetal harm when administered to pregnant women [see *Use in Specific Populations (8.1, 8.3)*].

2.2 Laboratory Testing in Patients with Advanced Chronic Kidney Disease Prior to Initiation of OSVYRTI

In patients with advanced chronic kidney disease [i.e., estimated glomerular filtration rate (eGFR) <30 mL/min/1.73 m²], including dialysis-dependent patients, evaluate for the presence of chronic kidney disease mineral and bone disorder (CKD-MBD) with intact parathyroid hormone (iPTH), serum calcium, 25(OH) vitamin D, and 1,25 (OH)₂ vitamin D prior to decisions regarding OSVYRTI treatment. Consider also assessing bone turnover status (serum markers of bone turnover or bone biopsy) to evaluate the underlying bone disease that may be present [see *Warnings and Precautions (5.1)*].

2.3 Recommended Dosage

OSVYRTI should be administered by a healthcare provider.

The recommended dose of OSVYRTI is 60 mg administered as a single subcutaneous injection once every 6 months. Administer OSVYRTI via subcutaneous injection in the upper arm, the upper thigh, or the abdomen. All patients should receive calcium 1000 mg daily and at least 400 IU vitamin D daily [see *Warnings and Precautions (5.1)*].

If a dose of OSVYRTI is missed, administer the injection as soon as the patient is available. Thereafter, schedule injections every 6 months from the date of the last injection.

2.4 Preparation and Administration

Parenteral drug products should be inspected visually for particulate matter and discoloration prior to administration whenever solution and container permit. OSVYRTI is a clear, colorless to pale yellow solution. Do not use if the solution is discolored or cloudy or if the solution contains particles or foreign particulate matter.

Prior to administration, OSVYRTI may be removed from the refrigerator and brought to room temperature up to 25°C (77°F) by standing in the original container. This generally takes 15 to 30 minutes. Do not warm OSVYRTI in any other way [see *How Supplied/Storage and Handling (16)*].

Instructions for Administration of Osvyrti Prefilled Syringe with Needle Safety Guard

IMPORTANT: In order to minimize accidental needlesticks, the OSVYRTI single-dose prefilled syringe will have a safety guard that will be activated to cover the needle after the

injection is given.

DO NOT touch the needle guard activation clips before use. Touching them may cause the syringe needle guard to be activated too early. Grab the safety guard to remove the prefilled syringe from the tray.

If transparent needle guard is covering needle cover, the needle guard has already been activated. Do not use prefilled syringe if needle guard is activated. Get another prefilled syringe that has not been activated and is ready for use.

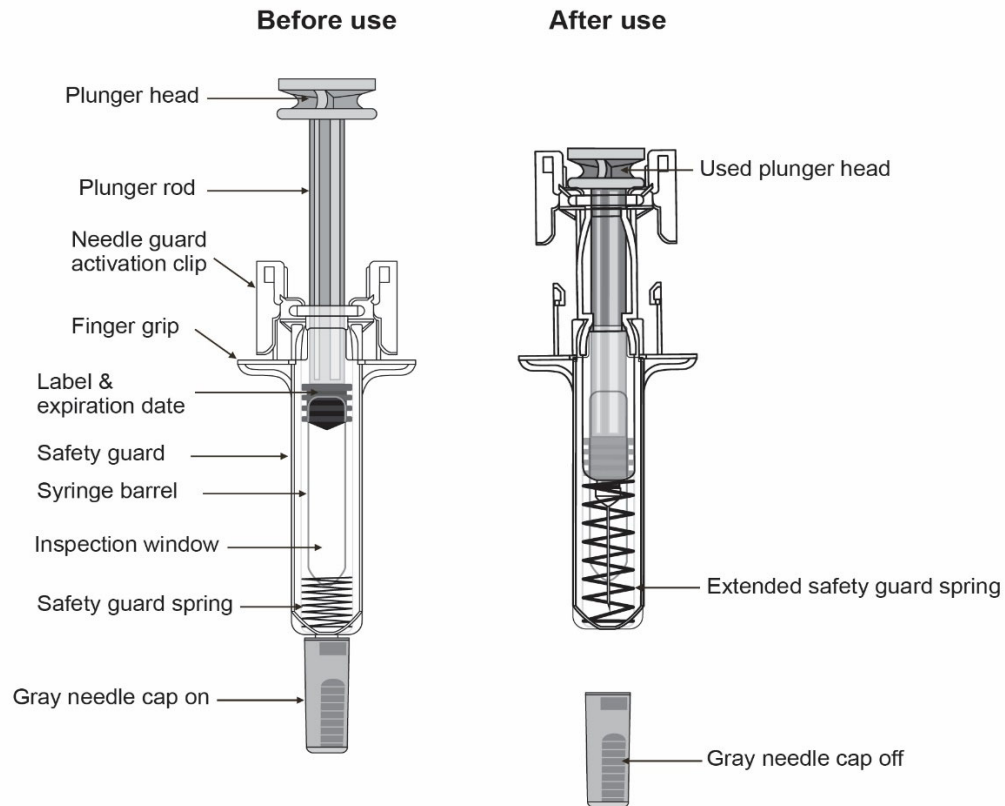

Needle guard is activated once the pressure is released from the plunger after injection.

DO NOT use the prefilled syringe if it has been dropped on a hard surface. Use a new prefilled syringe.

Step 1: Remove Gray Needle Cap

Remove needle cap

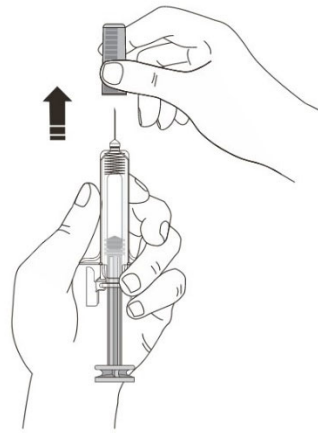

Step 2: Administer Subcutaneous Injection

Choose an injection site.
The recommended injection sites for OSVYRTI include: the upper arm OR the upper thigh OR the abdomen.

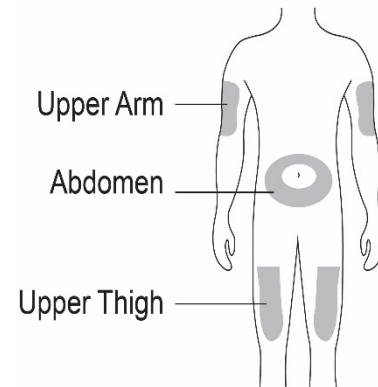

Insert needle and inject all the liquid subcutaneously. Do not administer into muscle or blood vessel.

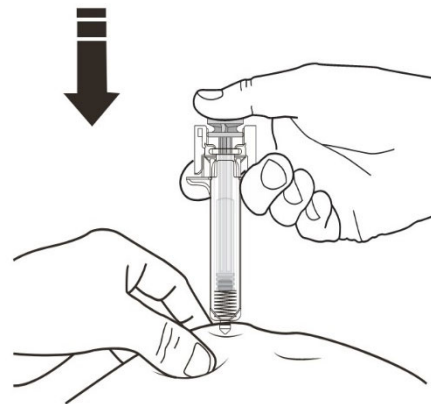

Keep the plunger fully pressed down while you carefully pull needle straight out from the injection site.

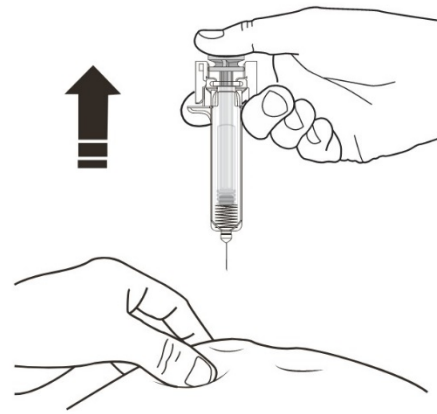

DO NOT put gray needle cap back on needle.

Step 3: Needle Safety Guard Activation

Slowly release the plunger and allow the needle guard to automatically cover the exposed needle.

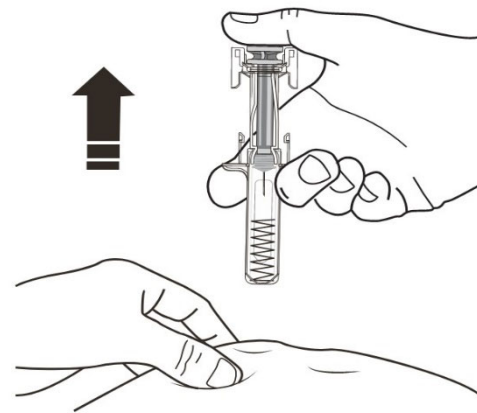

Immediately dispose of the syringe and needle cap in the nearest sharps container. **DO NOT** put the needle cap back on the used syringe.

3 DOSAGE FORMS AND STRENGTHS

- Injection: 60 mg/mL clear, colorless to pale yellow solution in a single-dose prefilled syringe.

4 CONTRAINDICATIONS

OSVYRTI is contraindicated in:

- Patients with hypocalcemia: Pre-existing hypocalcemia must be corrected prior to initiating therapy with OSVYRTI [see *Warnings and Precautions (5.1)*].
- Pregnant women: Denosumab products may cause fetal harm when administered to a pregnant woman. In women of reproductive potential, pregnancy testing should be performed prior to initiating treatment with OSVYRTI [see *Use in Specific Populations (8.1)*].
- Patients with hypersensitivity to denosumab products: OSVYRTI is contraindicated in

patients with a history of systemic hypersensitivity to any component of the product. Reactions have included anaphylaxis, facial swelling, and urticaria [*see Warnings and Precautions (5.3), Adverse Reactions (6.2)*].

5 WARNINGS AND PRECAUTIONS

5.1 Severe Hypocalcemia and Mineral Metabolism Changes

Denosumab products can cause severe hypocalcemia and fatal cases have been reported. Pre-existing hypocalcemia must be corrected prior to initiating therapy with OSVYRTI. Adequately supplement all patients with calcium and vitamin D [*see Dosage and Administration (2.1), Contraindications (4), and Adverse Reactions (6.1)*].

In patients without advanced chronic kidney disease who are predisposed to hypocalcemia and disturbances of mineral metabolism (e.g. history of hypoparathyroidism, thyroid surgery, parathyroid surgery, malabsorption syndromes, excision of small intestine, treatment with other calcium-lowering drugs), assess serum calcium and mineral levels (phosphorus and magnesium) 10 to 14 days after OSVYRTI injection. In some postmarketing cases, hypocalcemia persisted for weeks or months and required frequent monitoring and intravenous and/or oral calcium replacement, with or without vitamin D.

Patients with Advanced Chronic Kidney Disease

Patients with advanced chronic kidney disease [i.e., eGFR <30 mL/min/1.73 m²] including dialysis-dependent patients are at greater risk for severe hypocalcemia following denosumab products administration. Severe hypocalcemia resulting in hospitalization, life-threatening events and fatal cases have been reported. The presence of underlying chronic kidney disease-mineral bone disorder (CKD-MBD, renal osteodystrophy) markedly increases the risk of hypocalcemia. Concomitant use of calcimimetic drugs may also worsen hypocalcemia risk.

To minimize the risk of hypocalcemia in patients with advanced chronic kidney disease, evaluate for the presence of chronic kidney disease mineral and bone disorder with intact parathyroid hormone (iPTH), serum calcium, 25(OH) vitamin D, and 1,25(OH)₂ vitamin D prior to decisions regarding OSVYRTI treatment. Consider also assessing bone turnover status (serum markers of bone turnover or bone biopsy) to evaluate the underlying bone disease that may be present. Monitor serum calcium weekly for the first month after OSVYRTI administration and monthly thereafter. Instruct all patients with advanced chronic kidney disease, including those who are dialysis-dependent, about the symptoms of hypocalcemia and the importance of maintaining serum calcium levels with adequate calcium and activated vitamin D supplementation. Treatment with OSVYRTI in these patients should be supervised by a healthcare provider who is experienced in diagnosis and management of CKD-MBD.

5.2 Drug Products with Same Active Ingredient

Patients receiving OSVYRTI should not receive other denosumab products concomitantly.

5.3 Hypersensitivity

Clinically significant hypersensitivity including anaphylaxis has been reported with denosumab products. Symptoms have included hypotension, dyspnea, throat tightness, facial and upper airway edema, pruritus, and urticaria. If an anaphylactic or other clinically significant allergic reaction occurs, initiate appropriate therapy and discontinue further use of OSVYRTI [*see Contraindications (4), Adverse Reactions (6.2)*].

5.4 Osteonecrosis of the Jaw

Osteonecrosis of the jaw (ONJ), which can occur spontaneously, is generally associated with tooth extraction and/or local infection with delayed healing. ONJ has been reported in patients receiving denosumab products [see *Adverse Reactions (6.1)*]. A routine oral exam should be performed by the prescriber prior to initiation of OSVYRTI treatment. A dental examination with appropriate preventive dentistry is recommended prior to treatment with OSVYRTI in patients with risk factors for ONJ such as invasive dental procedures (e.g. tooth extraction, dental implants, oral surgery), diagnosis of cancer, concomitant therapies (e.g. chemotherapy, corticosteroids, angiogenesis inhibitors), poor oral hygiene, and comorbid disorders (e.g. periodontal and/or other pre-existing dental disease, anemia, coagulopathy, infection, ill-fitting dentures). Good oral hygiene practices should be maintained during treatment with OSVYRTI. Concomitant administration of drugs associated with ONJ may increase the risk of developing ONJ. The risk of ONJ may increase with duration of exposure to denosumab products.

For patients requiring invasive dental procedures, clinical judgment of the treating physician and/or oral surgeon should guide the management plan of each patient based on individual benefit-risk assessment.

Patients who are suspected of having or who develop ONJ while on OSVYRTI should receive care by a dentist or an oral surgeon. In these patients, extensive dental surgery to treat ONJ may exacerbate the condition. Discontinuation of OSVYRTI therapy should be considered based on individual benefit-risk assessment.

5.5 Atypical Subtrochanteric and Diaphyseal Femoral Fractures

Atypical low energy or low trauma fractures of the shaft have been reported in patients receiving denosumab products [see *Adverse Reactions (6.1)*]. These fractures can occur anywhere in the femoral shaft from just below the lesser trochanter to above the supracondylar flare and are transverse or short oblique in orientation without evidence of comminution. Causality has not been established as these fractures also occur in osteoporotic patients who have not been treated with antiresorptive agents.

Atypical femoral fractures most commonly occur with minimal or no trauma to the affected area. They may be bilateral, and many patients report prodromal pain in the affected area, usually presenting as dull, aching thigh pain, weeks to months before a complete fracture occurs. A number of reports note that patients were also receiving treatment with glucocorticoids (e.g. prednisone) at the time of fracture.

During OSVYRTI treatment, patients should be advised to report new or unusual thigh, hip, or groin pain. Any patient who presents with thigh or groin pain should be suspected of having an atypical fracture and should be evaluated to rule out an incomplete femur fracture. Patient presenting with an atypical femur fracture should also be assessed for symptoms and signs of fracture in the contralateral limb. Interruption of OSVYRTI therapy should be considered, pending a benefit-risk assessment, on an individual basis.

5.6 Multiple Vertebral Fractures (MVF) Following Discontinuation of Treatment

Following discontinuation of denosumab treatment, fracture risk increases, including the risk of multiple vertebral fractures. Treatment with denosumab results in significant suppression of bone turnover and cessation of denosumab treatment results in increased bone turnover above pretreatment values 9 months after the last dose of denosumab. Bone turnover then returns to pretreatment values 24 months after the last dose of denosumab. In addition, bone mineral density (BMD) returns to pretreatment values within 18 months after the last

injection [see *Clinical Pharmacology (12.2)*, *Clinical Studies (14.1)*].

New vertebral fractures occurred as early as 7 months (on average 19 months) after the last dose of denosumab. Prior vertebral fracture was a predictor of multiple vertebral fractures after denosumab discontinuation. Evaluate an individual's benefit-risk before initiating treatment with OSVYRTI.

If OSVYRTI treatment is discontinued, patients should be transitioned to an alternative antiresorptive therapy [see *Adverse Reactions (6.1)*].

5.7 Serious Infections

In a clinical trial of over 7800 women with postmenopausal osteoporosis, serious infections leading to hospitalization were reported more frequently in the denosumab group than in the placebo group [see *Adverse Reactions (6.1)*]. Serious skin infections, as well as infections of the abdomen, urinary tract, and ear, were more frequent in patients treated with denosumab. Endocarditis was also reported more frequently in denosumab-treated patients. The incidence of opportunistic infections was similar between placebo and denosumab groups, and the overall incidence of infections was similar between the treatment groups. Advise patients to seek prompt medical attention if they develop signs or symptoms of severe infection, including cellulitis.

Patients on concomitant immunosuppressant agents or with impaired immune systems may be at increased risk for serious infections. Consider the benefit-risk profile in such patients before treating with OSVYRTI. In patients who develop serious infections while on OSVYRTI, prescribers should assess the need for continued OSVYRTI therapy.

5.8 Dermatologic Adverse Reactions

In a large clinical trial of over 7800 women with postmenopausal osteoporosis, epidermal and dermal adverse events such as dermatitis, eczema, and rashes occurred at a significantly higher rate in the denosumab group compared to the placebo group. Most of these events were not specific to the injection site [see *Adverse Reactions (6.1)*]. Consider discontinuing OSVYRTI if severe symptoms develop.

5.9 Musculoskeletal Pain

In postmarketing experience, severe and occasionally incapacitating bone, joint, and/or muscle pain has been reported in patients taking denosumab products [see *Adverse Reactions (6.2)*]. The time to onset of symptoms varied from one day to several months after starting denosumab products. Consider discontinuing use if severe symptoms develop [see *Patient Counseling Information (17)*].

5.10 Suppression of Bone Turnover

In clinical trials in women with postmenopausal osteoporosis, treatment with denosumab resulted in significant suppression of bone remodeling as evidenced by markers of bone turnover and bone histomorphometry [see *Clinical Pharmacology (12.2)*, *Clinical Studies (14.1)*]. The significance of these findings and the effect of long-term treatment with denosumab products are unknown. The long-term consequences of the degree of suppression of bone remodeling observed with denosumab may contribute to adverse outcomes such as osteonecrosis of the jaw, atypical fractures, and delayed fracture healing. Monitor patients for these consequences.

5.11 Hypercalcemia in Pediatric Patients with Osteogenesis Imperfecta

OSVYRTI is not approved for use in pediatric patients. Hypercalcemia has been reported in pediatric patients with osteogenesis imperfecta treated with denosumab products. Some cases required hospitalization [see *Use in Specific Populations (8.4)*].

6 ADVERSE REACTIONS

The following serious adverse reactions are discussed below and also elsewhere in the labeling:

- Severe Hypocalcemia and Mineral Metabolism Changes [see *Warnings and Precautions (5.1)*]
- Hypersensitivity [see *Warnings and Precautions (5.3)*]
- Osteonecrosis of the Jaw [see *Warnings and Precautions (5.4)*]
- Atypical Subtrochanteric and Diaphyseal Femoral Fractures [see *Warnings and Precautions (5.5)*]
- Multiple Vertebral Fractures (MVF) Following Treatment Discontinuation [see *Warnings and Precautions (5.6)*]
- Serious Infections [see *Warnings and Precautions (5.7)*]
- Dermatologic Adverse Reactions [see *Warnings and Precautions (5.8)*]

The most common adverse reactions reported with denosumab products in patients with postmenopausal osteoporosis are back pain, pain in extremity, musculoskeletal pain, hypercholesterolemia, and cystitis.

The most common adverse reactions reported with denosumab products in men with osteoporosis are back pain, arthralgia, and nasopharyngitis.

The most common adverse reactions reported with denosumab products in patients with glucocorticoid-induced osteoporosis are back pain, hypertension, bronchitis, and headache.

The most common (per patient incidence $\geq 10\%$) adverse reactions reported with denosumab products in patients with bone loss receiving androgen deprivation therapy for prostate cancer or adjuvant aromatase inhibitor therapy for breast cancer are arthralgia and back pain. Pain in extremity and musculoskeletal pain have also been reported in clinical trials.

The most common adverse reactions leading to discontinuation of denosumab in patients with postmenopausal osteoporosis are back pain and constipation.

6.1 Clinical Trials Experience

Because clinical studies are conducted under widely varying conditions, adverse reaction rates observed in the clinical studies of a drug cannot be directly compared to rates in the clinical studies of another drug and may not reflect the rates observed in clinical practice.

Treatment of Postmenopausal Women with Osteoporosis

The safety of denosumab in the treatment of postmenopausal osteoporosis was assessed in a 3-year, randomized, double-blind, placebo-controlled, multinational study of 7808 postmenopausal women aged 60 to 91 years. A total of 3876 women were exposed to placebo and 3886 women were exposed to denosumab administered subcutaneously once every 6 months as a single 60 mg dose. All women were instructed to take at least 1000 mg of calcium and 400 IU of vitamin D supplementation per day.

The incidence of all-cause mortality was 2.3% (n = 90) in the placebo group and 1.8% (n = 70) in the denosumab group. The incidence of nonfatal serious adverse events was 24.2% in the placebo group and 25.0% in the denosumab group. The percentage of patients who withdrew from the study due to adverse events was 2.1% and 2.4% for the placebo and denosumab groups, respectively. The most common adverse reactions reported with denosumab in patients with postmenopausal osteoporosis are back pain, pain in extremity, musculoskeletal pain, hypercholesterolemia, and cystitis.

Adverse reactions reported in $\geq 2\%$ of postmenopausal women with osteoporosis and more frequently in the denosumab-treated women than in the placebo-treated women are shown in the table below.

Table 1. Adverse Reactions Occurring in $\geq 2\%$ of Patients with Osteoporosis and More Frequently than in Placebo-treated Patients

Preferred Term	Denosumab (N = 3886) n (%)	Placebo (N = 3876) n (%)
Back pain	1347 (34.7)	1340 (34.6)
Pain in extremity	453 (11.7)	430 (11.1)
Musculoskeletal pain	297 (7.6)	291 (7.5)
Hypercholesterolemia	280 (7.2)	236 (6.1)
Cystitis	228 (5.9)	225 (5.8)
Vertigo	195 (5.0)	187 (4.8)
Upper respiratory tract infection	190 (4.9)	167 (4.3)
Edema peripheral	189 (4.9)	155 (4.0)
Sciatica	178 (4.6)	149 (3.8)
Bone pain	142 (3.7)	117 (3.0)
Abdominal pain upper	129 (3.3)	111 (2.9)
Anemia	129(3.3)	107 (2.8)
Insomnia	126 (3.2)	122 (3.1)
Myalgia	114 (2.9)	94 (2.4)
Angina pectoris	101 (2.6)	87 (2.2)
Rash	96 (2.5)	79 (2.0)
Pharyngitis	91 (2.3)	78 (2.0)
Asthenia	90 (2.3)	73 (1.9)
Pruritus	87 (2.2)	82 (2.1)
Flatulence	84 (2.2)	53 (1.4)
Spinal osteoarthritis	82 (2.1)	64 (1.7)
Gastroesophageal reflux disease	80 (2.1)	66 (1.7)
Herpes zoster	79 (2.0)	72 (1.9)

Hypocalcemia

Decreases in serum calcium levels to less than 8.5 mg/dL at any visit were reported in 0.4% women in the placebo group and 1.7% women in the denosumab group. The nadir in serum calcium level occurred at approximately day 10 after denosumab dosing in subjects with normal renal function.

In clinical studies, subjects with impaired renal function were more likely to have greater reductions in serum calcium levels compared to subjects with normal renal function. In a study of 55 subjects with varying degrees of renal function, serum calcium levels < 7.5 mg/dL or symptomatic hypocalcemia were observed in 5 subjects. These included no subjects in the normal renal function group, 10% of subjects in the creatinine clearance 50 to 80 mL/min group, 29% of subjects in the creatinine clearance < 30 mL/min group, and 29% of subjects in the hemodialysis group. These subjects did not receive calcium and vitamin D supplementation. In a study of 4550 postmenopausal women with osteoporosis, the mean change from baseline in serum calcium level 10 days after denosumab dosing was -5.5% in subjects with creatinine clearance < 30 mL/min vs. -3.1% in subjects with creatinine clearance ≥ 30 mL/min.

Serious Infections

Receptor activator of nuclear factor kappa-B ligand (RANKL) is expressed on activated T and B lymphocytes and in lymph nodes. Therefore, a RANKL inhibitor such as denosumab products may increase the risk of infection.

In the clinical study of 7808 postmenopausal women with osteoporosis, the incidence of infections resulting in death was 0.2% in both placebo and denosumab treatment groups. However, the incidence of nonfatal serious infections was 3.3% in the placebo and 4.0% in the denosumab groups. Hospitalizations due to serious infections in the abdomen (0.7% placebo vs. 0.9% denosumab), urinary tract (0.5% placebo vs. 0.7% denosumab), and ear (0.0% placebo vs. 0.1% denosumab) were reported. Endocarditis was reported in no placebo patients and 3 patients receiving denosumab.

Skin infections, including erysipelas and cellulitis, leading to hospitalization were reported more frequently in patients treated with denosumab (< 0.1% placebo vs. 0.4% denosumab).

The incidence of opportunistic infections was similar to that reported with placebo.

Dermatologic Adverse Reactions

A significantly higher number of patients treated with denosumab developed epidermal and dermal adverse events (such as dermatitis, eczema, and rashes), with these events reported in 8.2% of the placebo and 10.8% of the denosumab groups ($p < 0.0001$). Most of these events were not specific to the injection site [see *Warnings and Precautions* (5.8)].

Osteonecrosis of the Jaw

ONJ has been reported in the osteoporosis clinical trial program in patients treated with denosumab [see *Warnings and Precautions* (5.4)].

Atypical Subtrochanteric and Diaphyseal Femoral Fractures

In the osteoporosis clinical trial program, atypical femoral fractures were reported in patients treated with denosumab. The duration of denosumab exposure to time of atypical femoral fracture diagnosis was as early as 2½ years [see *Warnings and Precautions* (5.5)].

Multiple Vertebral Fractures (MVF) Following Treatment Discontinuation

In the osteoporosis clinical trial program, multiple vertebral fractures were reported in patients after discontinuation of denosumab. In the phase 3 trial in women with postmenopausal osteoporosis, 6% of women who discontinued denosumab and remained in the study developed new vertebral fractures, and 3% of women who discontinued denosumab and remained in the study developed multiple new vertebral fractures. The mean time to onset of multiple vertebral fractures was 17 months (range: 7-43 months) after the last injection of denosumab. Prior vertebral fracture was a predictor of multiple vertebral fractures after discontinuation [see *Warnings and Precautions* (5.6)].

Pancreatitis

Pancreatitis was reported in 4 patients (0.1%) in the placebo and 8 patients (0.2%) in the denosumab groups. Of these reports, 1 patient in the placebo group and all 8 patients in the denosumab group had serious events, including one death in the denosumab group. Several patients had a prior history of pancreatitis. The time from product administration to event occurrence was variable.

New Malignancies

The overall incidence of new malignancies was 4.3% in the placebo and 4.8% in the denosumab groups. New malignancies related to the breast (0.7% placebo vs. 0.9% denosumab), reproductive system (0.2% placebo vs. 0.5% denosumab), and gastrointestinal system (0.6% placebo vs. 0.9% denosumab) were reported. A causal relationship to drug exposure has not been established.

Treatment to Increase Bone Mass in Men with Osteoporosis

The safety of denosumab in the treatment of men with osteoporosis was assessed in a 1-year randomized, double-blind, placebo-controlled study. A total of 120 men were exposed to placebo and 120 men were exposed to denosumab administered subcutaneously once every 6 months as a single 60 mg dose. All men were instructed to take at least 1000 mg of calcium and 800 IU of vitamin D supplementation per day.

The incidence of all-cause mortality was 0.8% (n = 1) in the placebo group and 0.8% (n = 1) in the denosumab group. The incidence of nonfatal serious adverse events was 7.5% in the placebo group and 8.3% in the denosumab group. The percentage of patients who withdrew from the study due to adverse events was 0% and 2.5% for the placebo and denosumab groups, respectively.

Adverse reactions reported in $\geq 5\%$ of men with osteoporosis and more frequently with denosumab than in the placebo-treated patients were: back pain (6.7% placebo vs. 8.3% denosumab), arthralgia (5.8% placebo vs. 6.7% denosumab), and nasopharyngitis (5.8% placebo vs. 6.7% denosumab).

Serious Infections

Serious infection was reported in 1 patient (0.8%) in the placebo group and no patients in the denosumab group.

Dermatologic Adverse Reactions

Epidermal and dermal adverse events (such as dermatitis, eczema, and rashes) were reported in 4 patients (3.3%) in the placebo group and 5 patients (4.2%) in the denosumab group.

Osteonecrosis of the Jaw

No cases of ONJ were reported.

Pancreatitis

Pancreatitis was reported in 1 patient (0.8%) in the placebo group and 1 patient (0.8%) in the denosumab group.

New Malignancies

New malignancies were reported in no patients in the placebo group and 4 (3.3%) patients (3 prostate cancers, 1 basal cell carcinoma) in the denosumab group.

Treatment of Glucocorticoid-Induced Osteoporosis

The safety of denosumab in the treatment of glucocorticoid-induced osteoporosis was

assessed in the 1-year, primary analysis of a 2-year randomized, multicenter, double-blind, parallel-group, active-controlled study of 795 patients (30% men and 70% women) aged 20 to 94 (mean age of 63 years) treated with greater than or equal to 7.5 mg/day oral prednisone (or equivalent). A total of 384 patients were exposed to 5 mg oral daily bisphosphonate (active-control) and 394 patients were exposed to denosumab administered once every 6 months as a 60 mg subcutaneous dose. All patients were instructed to take at least 1000 mg of calcium and 800 IU of vitamin D supplementation per day.

The incidence of all-cause mortality was 0.5% (n = 2) in the active-control group and 1.5% (n = 6) in the denosumab group. The incidence of serious adverse events was 17% in the active-control group and 16% in the denosumab group. The percentage of patients who withdrew from the study due to adverse events was 3.6% and 3.8% for the active-control and denosumab groups, respectively.

Adverse reactions reported in $\geq 2\%$ of patients with glucocorticoid-induced osteoporosis and more frequently with denosumab than in the active-control-treated patients are shown in the table below.

Table 2. Adverse Reactions Occurring in $\geq 2\%$ of Patients with Glucocorticoid-induced Osteoporosis and More Frequently with Denosumab than in Active-Control-treated Patients

Preferred Term	Denosumab (N = 394) n (%)	Oral Daily Bisphosphonate (Active-Control) (N = 384) n (%)
Back pain	18 (4.6)	17 (4.4)
Hypertension	15 (3.8)	13 (3.4)
Bronchitis	15 (3.8)	11 (2.9)
Headache	14 (3.6)	7 (1.8)
Dyspepsia	12 (3.0)	10 (2.6)
Urinary tract infection	12 (3.0)	8 (2.1)
Abdominal pain upper	12 (3.0)	7 (1.8)
Upper respiratory tract infection	11 (2.8)	10 (2.6)
Constipation	11 (2.8)	6 (1.6)
Vomiting	10 (2.5)	6 (1.6)
Dizziness	9 (2.3)	8 (2.1)
Fall	8 (2.0)	7 (1.8)
Polymyalgia rheumatica*	8 (2.0)	1 (0.3)

*Events of worsening of underlying polymyalgia rheumatica.

Osteonecrosis of the Jaw

No cases of ONJ were reported.

Atypical Subtrochanteric and Diaphyseal Femoral Fractures

Atypical femoral fractures were reported in 1 patient treated with denosumab. The duration of denosumab exposure to time of atypical femoral fracture diagnosis was at 8.0 months [see *Warnings and Precautions (5.5)*].

Serious Infections

Serious infection was reported in 15 patients (3.9%) in the active-control group and 17

patients (4.3%) in the denosumab group.

Dermatologic Adverse Reactions

Epidermal and dermal adverse events (such as dermatitis, eczema, and rashes) were reported in 16 patients (4.2%) in the active-control group and 15 patients (3.8%) in the denosumab group.

Treatment of Bone Loss in Patients Receiving Androgen Deprivation Therapy for Prostate Cancer or Adjuvant Aromatase Inhibitor Therapy for Breast Cancer

The safety of denosumab in the treatment of bone loss in men with nonmetastatic prostate cancer receiving androgen deprivation therapy (ADT) was assessed in a 3-year, randomized, double-blind, placebo-controlled, multinational study of 1468 men aged 48 to 97 years. A total of 725 men were exposed to placebo and 731 men were exposed to denosumab administered once every 6 months as a single 60 mg subcutaneous dose. All men were instructed to take at least 1000 mg of calcium and 400 IU of vitamin D supplementation per day.

The incidence of serious adverse events was 30.6% in the placebo group and 34.6% in the denosumab group. The percentage of patients who withdrew from the study due to adverse events was 6.1% and 7.0% for the placebo and denosumab groups, respectively.

The safety of denosumab in the treatment of bone loss in women with nonmetastatic breast cancer receiving aromatase inhibitor (AI) therapy was assessed in a 2-year, randomized, double-blind, placebo-controlled, multinational study of 252 postmenopausal women aged 35 to 84 years. A total of 120 women were exposed to placebo and 129 women were exposed to denosumab administered once every 6 months as a single 60 mg subcutaneous dose. All women were instructed to take at least 1000 mg of calcium and 400 IU of vitamin D supplementation per day.

The incidence of serious adverse events was 9.2% in the placebo group and 14.7% in the denosumab group. The percentage of patients who withdrew from the study due to adverse events was 4.2% and 0.8% for the placebo and denosumab groups, respectively.

Adverse reactions reported in $\geq 10\%$ of denosumab-treated patients receiving ADT for prostate cancer or adjuvant AI therapy for breast cancer, and more frequently than in the placebo-treated patients were: arthralgia (13.0% placebo vs. 14.3% denosumab) and back pain (10.5% placebo vs. 11.5% denosumab). Pain in extremity (7.7% placebo vs. 9.9% denosumab) and musculoskeletal pain (3.8% placebo vs. 6.0% denosumab) have also been reported in clinical trials. Additionally, in denosumab-treated men with nonmetastatic prostate cancer receiving ADT, a greater incidence of cataracts was observed (1.2% placebo vs. 4.7% denosumab). Hypocalcemia (serum calcium < 8.4 mg/dL) was reported only in denosumab-treated patients (2.4% vs. 0.0%) at the month 1 visit.

6.2 Postmarketing Experience

Because postmarketing reactions are reported voluntarily from a population of uncertain size, it is not always possible to reliably estimate their frequency or establish a causal relationship to drug exposure.

The following adverse reactions have been identified during post-approval use of denosumab products:

- Drug-related hypersensitivity reactions: anaphylaxis, rash, urticaria, facial swelling, and erythema

- Hypocalcemia: severe symptomatic hypocalcemia resulting in hospitalization, life-threatening events, and fatal cases
- Musculoskeletal pain, including severe cases
- Parathyroid Hormone (PTH): Marked elevation in serum PTH in patients with severe renal impairment (creatinine clearance < 30 mL/min) or receiving dialysis
- Multiple vertebral fractures following treatment discontinuation
- Cutaneous and mucosal lichenoid drug eruptions (e.g. lichen planus-like reactions)
- Alopecia
- Vasculitis (e.g., ANCA positive vasculitis, leukocytoclastic vasculitis)
- Drug reaction with eosinophilia and systemic symptoms (DRESS) syndrome

8 USE IN SPECIFIC POPULATIONS

8.1 Pregnancy

Risk Summary

OSVYRTI is contraindicated for use in pregnant women because it may cause harm to a fetus. There are insufficient data with denosumab products use in pregnant women to inform any drug-associated risks for adverse developmental outcomes. *In utero* denosumab exposure from cynomolgus monkeys dosed monthly with denosumab throughout pregnancy at a dose 50-fold higher than the recommended human dose based on body weight resulted in increased fetal loss, stillbirths, and postnatal mortality, and absent lymph nodes, abnormal bone growth, and decreased neonatal growth [*see Data*].

Data

Animal Data

The effects of denosumab on prenatal development have been studied in both cynomolgus monkeys and genetically engineered mice in which RANK ligand (RANKL) expression was turned off by gene removal (a “knockout mouse”). In cynomolgus monkeys dosed subcutaneously with denosumab throughout pregnancy starting at gestational day 20 and at a pharmacologically active dose 50-fold higher than the recommended human dose based on body weight, there was increased fetal loss during gestation, stillbirths, and postnatal mortality. Other findings in offspring included absence of axillary, inguinal, mandibular, and mesenteric lymph nodes; abnormal bone growth, reduced bone strength, reduced hematopoiesis, dental dysplasia, and tooth malalignment; and decreased neonatal growth. At birth out to 1 month of age, infants had measurable blood levels of denosumab (22-621% of maternal levels).

Following a recovery period from birth out to 6 months of age, the effects on bone quality and strength returned to normal; there were no adverse effects on tooth eruption, though dental dysplasia was still apparent; axillary and inguinal lymph nodes remained absent, while mandibular and mesenteric lymph nodes were present, though small; and minimal to moderate mineralization in multiple tissues was seen in one recovery animal. There was no evidence of maternal harm prior to labor; adverse maternal effects occurred infrequently during labor. Maternal mammary gland development was normal. There was no fetal NOAEL (no observable adverse effect level) established for this study because only one dose of 50 mg/kg was evaluated. Mammary gland histopathology at 6 months of age was normal in female offspring exposed to denosumab *in utero*; however, development and lactation have not been fully evaluated.

In RANKL knockout mice, absence of RANKL (the target of denosumab) also caused fetal

lymph node agenesis and led to postnatal impairment of dentition and bone growth. Pregnant RANKL knockout mice showed altered maturation of the maternal mammary gland, leading to impaired lactation [see Use in Specific Populations (8.2), Nonclinical Toxicology (13.2)].

The no effect dose for denosumab product-induced teratogenicity is unknown. However, a C_{max} of 22.9 ng/mL was identified in cynomolgus monkeys as a level in which no biologic effects (NOEL) of denosumab were observed (no inhibition of RANKL) [see Clinical Pharmacology (12.3)].

8.2 Lactation

Risk Summary

There is no information regarding the presence of denosumab products in human milk, the effects on the breastfed infant, or the effects on milk production. Denosumab was detected in the maternal milk of cynomolgus monkeys up to 1 month after the last dose of denosumab (\leq 0.5% milk:serum ratio) and maternal mammary gland development was normal, with no impaired lactation. However, pregnant RANKL knockout mice showed altered maturation of the maternal mammary gland, leading to impaired lactation [see Use in Specific Populations (8.1), Nonclinical Toxicology (13.2)].

8.3 Females and Males of Reproductive Potential

Based on findings in animals, denosumab products can cause fetal harm when administered to a pregnant woman [see Use in Specific Populations (8.1)].

Pregnancy Testing

Verify the pregnancy status of females of reproductive potential prior to initiating OSVYRTI treatment.

Contraception

Females

Advise females of reproductive potential to use effective contraception during therapy, and for at least 5 months after the last dose of OSVYRTI.

Males

Denosumab was present at low concentrations (approximately 2% of serum exposure) in the seminal fluid of male subjects given denosumab. Following vaginal intercourse, the maximum amount of denosumab delivered to a female partner would result in exposures approximately 11000 times lower than the prescribed 60 mg subcutaneous dose, and at least 38 times lower than the NOEL in monkeys.

Therefore, male condom use would not be necessary as it is unlikely that a female partner or fetus would be exposed to pharmacologically relevant concentrations of denosumab products via seminal fluid [see Clinical Pharmacology (12.3)].

8.4 Pediatric Use

The safety and effectiveness of OSVYRTI have not been established in pediatric patients.

In one multicenter, open-label study with denosumab conducted in 153 pediatric patients with osteogenesis imperfecta, aged 2 to 17 years, evaluating fracture risk reduction, efficacy was not demonstrated.

Hypercalcemia has been reported in pediatric patients with osteogenesis imperfecta treated with denosumab products. Some cases required hospitalization and were complicated by acute renal injury [see *Warnings and Precautions (5.11)*]. Clinical studies in pediatric patients with osteogenesis imperfecta were terminated early due to the occurrence of life-threatening events and hospitalizations due to hypercalcemia.

Safety and effectiveness were not demonstrated for the treatment of glucocorticoid-induced osteoporosis in one multicenter, randomized, double-blind, placebo-controlled, parallel-group study conducted in 24 pediatric patients with glucocorticoid-induced osteoporosis, aged 5 to 17 years, evaluating change from baseline in lumbar spine BMD Z-score.

Based on results from animal studies, denosumab may negatively affect long-bone growth and dentition in pediatric patients below the age of 4 years.

Juvenile Animal Toxicity Data

Treatment with denosumab products may impair long-bone growth in children with open growth plates and may inhibit eruption of dentition. In neonatal rats, inhibition of RANKL (the target of denosumab therapy) with a construct of osteoprotegerin bound to Fc (OPG-Fc) at doses ≤ 10 mg/kg was associated with inhibition of bone growth and tooth eruption. Adolescent primates treated with denosumab at doses 10 and 50 times (10 and 50 mg/kg dose) higher than the recommended human dose of 60 mg administered every 6 months, based on body weight (mg/kg), had abnormal growth plates, considered to be consistent with the pharmacological activity of denosumab [see *Nonclinical Toxicology (13.2)*].

Cynomolgus monkeys exposed *in utero* to denosumab exhibited bone abnormalities, an absence of axillary, inguinal, mandibular, and mesenteric lymph nodes, reduced hematopoiesis, tooth malalignment, and decreased neonatal growth. Some bone abnormalities recovered once exposure was ceased following birth; however, axillary and inguinal lymph nodes remained absent 6 months post-birth [see *Use in Specific Populations (8.1)*].

8.5 Geriatric Use

Of the total number of patients in clinical studies of denosumab, 9943 patients (76%) were ≥ 65 years old, while 3576 (27%) were ≥ 75 years old. Of the patients in the osteoporosis study in men, 133 patients (55%) were ≥ 65 years old, while 39 patients (16%) were ≥ 75 years old. Of the patients in the glucocorticoid-induced osteoporosis study, 355 patients (47%) were ≥ 65 years old, while 132 patients (17%) were ≥ 75 years old. No overall differences in safety or efficacy were observed between these patients and younger patients, and other reported clinical experience has not identified differences in responses between the elderly and younger patients, but greater sensitivity of some older individuals cannot be ruled out.

8.6 Renal Impairment

No dose adjustment is necessary in patients with renal impairment.

Severe hypocalcemia resulting in hospitalization, life-threatening events and fatal cases have been reported postmarketing. In clinical studies, patients with advanced chronic kidney disease (i.e., eGFR < 30 mL/min/1.73 m²), including dialysis-dependent patients, were at greater risk of developing hypocalcemia. The presence of underlying chronic kidney disease-mineral bone disorder (CKD-MBD, renal osteodystrophy) markedly increases the risk of hypocalcemia. Concomitant use of calcimimetic drugs may also worsen hypocalcemia risk. Consider the benefits and risks to the patient when administering OSVYRTI to patients with advanced chronic kidney disease. Monitor calcium and mineral levels (phosphorus and

magnesium). Adequate intake of calcium and vitamin D is important in patients with advanced chronic kidney disease including dialysis-dependent patients [*see Dosage and Administration (2.2), Warnings and Precautions (5.1), Adverse Reactions (6.1) and Clinical Pharmacology (12.3)*].

11 DESCRIPTION

Denosumab-desu is a human IgG2 monoclonal antibody with affinity and specificity for human RANKL (receptor activator of nuclear factor kappa-B ligand). Denosumab-desu has an approximate molecular weight of 147 kDa and is produced in genetically engineered mammalian (Chinese hamster ovary) cells.

OSVYRTI (denosumab-desu) injection is a sterile, preservative-free, clear, colorless to pale yellow solution for subcutaneous use.

Each single-dose prefilled syringe of OSVYRTI contains 1 mL solution of 60 mg denosumab-desu, 1.08 mg glacial acetic acid, 0.1 mg polysorbate 20, 46 mg sorbitol, Water for Injection, and sodium hydroxide to adjust to a pH of 5.2.

12 CLINICAL PHARMACOLOGY

12.1 Mechanism of Action

Denosumab products bind to RANKL, a transmembrane or soluble protein essential for the formation, function, and survival of osteoclasts, the cells responsible for bone resorption. Denosumab products prevent RANKL from activating its receptor, RANK, on the surface of osteoclasts and their precursors. Prevention of the RANKL/RANK interaction inhibits osteoclast formation, function, and survival, thereby decreasing bone resorption and increasing bone mass and strength in both cortical and trabecular bone.

12.2 Pharmacodynamics

In clinical studies, treatment with 60 mg of denosumab resulted in reduction in the bone resorption marker serum type 1 C-telopeptide (CTX) by approximately 85% by 3 days, with maximal reductions occurring by 1 month. CTX levels were below the limit of assay quantitation (0.049 ng/mL) in 39% to 68% of patients 1 to 3 months after dosing of denosumab. At the end of each dosing interval, CTX reductions were partially attenuated from a maximal reduction of $\geq 87\%$ to $\geq 45\%$ (range: 45% to 80%), as serum denosumab levels diminished, reflecting the reversibility of the effects of denosumab on bone remodeling. These effects were sustained with continued treatment. Upon reinitiation, the degree of inhibition of CTX by denosumab was similar to that observed in patients initiating denosumab treatment.

Consistent with the physiological coupling of bone formation and resorption in skeletal remodeling, subsequent reductions in bone formation markers (i.e. osteocalcin and procollagen type 1 N-terminal peptide [P1NP]) were observed starting 1 month after the first dose of denosumab. After discontinuation of denosumab therapy, markers of bone resorption increased to levels 40% to 60% above pretreatment values but returned to baseline levels within 12 months.

12.3 Pharmacokinetics

In a study conducted in healthy male and female volunteers (n = 73, age range: 18 to 64 years) following a single subcutaneously administered denosumab dose of 60 mg, the mean area-under-the-concentration-time

curve up to 16 weeks ($AUC_{0-16 \text{ weeks}}$) of denosumab was 316 mcg·day/mL (SD = 101 mcg·day/mL). The mean maximum denosumab concentration (C_{\max}) was 6.75 mcg/mL (SD = 1.89 mcg/mL). No accumulation or change in denosumab pharmacokinetics with time is observed with multiple dosing of 60 mg subcutaneously administered once every 6 months.

Absorption

Following subcutaneous administration, the median time to maximum denosumab concentration (T_{\max}) was 10 days (range: 3 to 21 days).

Distribution

The mean volume of distribution for denosumab was 5.2 L (SD= 1.7 L).

Elimination

Serum denosumab concentrations declined over a period of 4 to 5 months with a mean half-life of 25.4 days (SD=8.5 days; n=46)

A population pharmacokinetic analysis was performed to evaluate the effects of demographic characteristics. This analysis showed no notable differences in pharmacokinetics with age (in postmenopausal women), race, or body weight (36 to 140 kg).

Seminal Fluid Pharmacokinetic Study

Serum and seminal fluid concentrations of denosumab were measured in 12 healthy male volunteers (age range: 43-65 years). After a single 60 mg subcutaneous administration of denosumab, the mean (\pm SD) C_{\max} values in the serum and seminal fluid samples were 6170 (\pm 2070) and 100 (\pm 81.9) ng/mL, respectively, resulting in a maximum seminal fluid concentration of approximately 2% of serum levels. The median (range) T_{\max} values in the serum and seminal fluid samples were 8.0 (7.9 to 21) and 21 (8.0 to 49) days, respectively. Among the subjects, the highest denosumab concentration in seminal fluid was 301 ng/mL at 22 days post-dose. On the first day of measurement (10 days post-dose), nine of eleven subjects had quantifiable concentrations in semen. On the last day of measurement (106 days post-dose), five subjects still had quantifiable concentrations of denosumab in seminal fluid, with a mean (\pm SD) seminal fluid concentration of 21.1 (\pm 36.5) ng/mL across all subjects (n = 12).

Drug Interactions

In a study of 19 postmenopausal women with low BMD and rheumatoid arthritis treated with etanercept (50 mg subcutaneous injection once weekly), a single-dose of denosumab (60 mg subcutaneous injection) was administered 7 days after the previous dose of etanercept. No clinically significant changes in the pharmacokinetics of etanercept were observed.

Cytochrome P450 substrates

In a study of 17 postmenopausal women with osteoporosis, midazolam (2 mg oral) was administered 2 weeks after a single-dose of denosumab (60 mg subcutaneous injection), which approximates the T_{\max} of denosumab. Denosumab did not affect the pharmacokinetics of midazolam, which is metabolized by cytochrome P450 3A4 (CYP3A4). This indicates that denosumab products should not alter the pharmacokinetics of drugs metabolized by CYP3A4 in postmenopausal women with osteoporosis.

Specific Populations

Gender: Mean serum denosumab concentration-time profiles observed in a study conducted in healthy men ≥ 50 years were similar to those observed in a study conducted in postmenopausal women using the same dose regimen.

Age: The pharmacokinetics of denosumab were not affected by age across all populations studied whose ages ranged from 28 to 87 years.

Race: The pharmacokinetics of denosumab were not affected by race.

Renal Impairment: In a study of 55 patients with varying degrees of renal function, including patients on dialysis, the degree of renal impairment had no effect on the pharmacokinetics of denosumab; thus, dose adjustment for renal impairment is not necessary.

Hepatic Impairment: No clinical studies have been conducted to evaluate the effect of hepatic impairment on the pharmacokinetics of denosumab products.

12.6 Immunogenicity

The observed incidence of anti-drug antibodies is highly dependent on the sensitivity and specificity of the assay. Differences in assay methods preclude meaningful comparisons of the incidence of anti-drug antibodies in the studies described below with the incidence of anti-drug antibodies in other studies, including those of denosumab or of other denosumab products.

Using an electrochemiluminescent bridging immunoassay, less than 1% (55 out of 8113) of patients treated with denosumab for up to 5 years tested positive for binding antibodies (including pre-existing, transient, and developing antibodies). None of the patients tested positive for neutralizing antibodies, as was assessed using a chemiluminescent cell-based in vitro biological assay.

There was no identified clinically significant effect of anti-drug antibodies on pharmacokinetics, pharmacodynamics, safety, or effectiveness of denosumab.

13 NONCLINICAL TOXICOLOGY

13.1 Carcinogenesis, Mutagenesis, Impairment of Fertility

Carcinogenicity

The carcinogenic potential of denosumab products has not been evaluated in long-term animal studies.

Mutagenicity

The genotoxic potential of denosumab products has not been evaluated.

Impairment of Fertility

Denosumab had no effect on female fertility or male reproductive organs in monkeys at doses that were 13- to 50-fold higher than the recommended human dose of 60 mg subcutaneously administered once every 6 months, based on body weight (mg/kg).

13.2 Animal Toxicology and/or Pharmacology

Denosumab products are inhibitors of osteoclastic bone resorption via inhibition of RANKL.

In ovariectomized monkeys, once-monthly treatment with denosumab suppressed bone turnover and increased BMD and strength of cancellous and cortical bone at doses 50-fold higher than the recommended human dose of 60 mg administered once every 6 months, based on body weight (mg/kg). Bone tissue was normal with no evidence of mineralization defects, accumulation of osteoid, or woven bone.

Because the biological activity of denosumab in animals is specific to nonhuman primates, evaluation of genetically engineered (“knockout”) mice or use of other biological inhibitors of the RANK/RANKL pathway, namely OPG-Fc, provided additional information on the pharmacodynamic properties of denosumab products. RANK/RANKL knockout mice exhibited absence of lymph node formation, as well as an absence of lactation due to inhibition of mammary gland maturation (lobulo-alveolar gland development during pregnancy). Neonatal RANK/RANKL knockout mice exhibited reduced bone growth and lack of tooth eruption. A corroborative study in 2-week-old rats given the RANKL inhibitor OPG-Fc also showed reduced bone growth, altered growth plates, and impaired tooth eruption. These changes were partially reversible in this model when dosing with the RANKL inhibitors was discontinued.

14 CLINICAL STUDIES

14.1 Treatment of Postmenopausal Women with Osteoporosis

The efficacy and safety of denosumab in the treatment of postmenopausal osteoporosis was demonstrated in a 3-year, randomized, double-blind, placebo-controlled trial. Enrolled women had a baseline BMD T-score between -2.5 and -4.0 at either the lumbar spine or total hip. Women with other diseases (such as rheumatoid arthritis, osteogenesis imperfecta, and Paget’s disease) or on therapies that affect bone were excluded from this study. The 7808 enrolled women were aged 60 to 91 years with a mean age of 72 years. Overall, the mean baseline lumbar spine BMD T-score was -2.8, and 23% of women had a vertebral fracture at baseline. Women were randomized to receive subcutaneous injections of either placebo (N = 3906) or denosumab 60 mg (N = 3902) once every 6 months. All women received at least 1000 mg calcium and 400 IU vitamin D supplementation daily.

The primary efficacy variable was the incidence of new morphometric (radiologically-diagnosed) vertebral fractures at 3 years. Vertebral fractures were diagnosed based on lateral spine radiographs (T4-L4) using a semiquantitative scoring method. Secondary efficacy variables included the incidence of hip fracture and nonvertebral fracture, assessed at 3 years.

Effect on Vertebral Fractures

Denosumab significantly reduced the incidence of new morphometric vertebral fractures at 1, 2, and 3 years ($p < 0.0001$), as shown in Table 3. The incidence of new vertebral fractures at year 3 was 7.2% in the placebo-treated women compared to 2.3% for the denosumab-treated women. The absolute risk reduction was 4.8% and relative risk reduction was 68% for new morphometric vertebral fractures at year 3.

Table 3. The Effect of Denosumab on the Incidence of New Vertebral Fractures in Postmenopausal Women

	Proportion of Women with Fracture (%) ⁺	Absolute Risk Reduction (%) [*] (95% CI)	Relative Risk Reduction (%) [*] (95% CI)

	Placebo N = 3691 (%)	Denosumab N = 3702 (%)		
0-1 Year	2.2	0.9	1.4 (0.8, 1.9)	61 (42, 74)
0-2 Years	5.0	1.4	3.5 (2.7, 4.3)	71 (61, 79)
0-3 Years	7.2	2.3	4.8 (3.9, 5.8)	68 (59, 74)

⁺ Event rates based on crude rates in each interval.

* Absolute risk reduction and relative risk reduction based on Mantel-Haenszel method adjusting for age group variable.

Denosumab was effective in reducing the risk for new morphometric vertebral fractures regardless of age, baseline rate of bone turnover, baseline BMD, baseline history of fracture, or prior use of a drug for osteoporosis.

Effect on Hip Fractures

The incidence of hip fracture was 1.2% for placebo-treated women compared to 0.7% for denosumab-treated women at year 3. The age-adjusted absolute risk reduction of hip fractures was 0.3% with a relative risk reduction of 40% at 3 years ($p = 0.04$) (see Figure 1).

Figure 1. Cumulative Incidence of Hip Fractures Over 3 Years

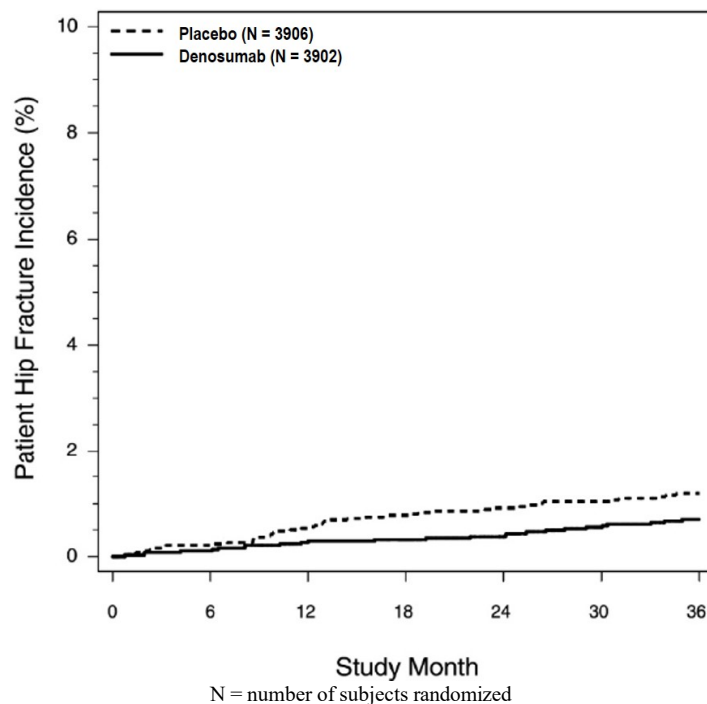

Effect on Nonvertebral Fractures

Treatment with denosumab resulted in a significant reduction in the incidence of nonvertebral fractures (see Table 4).

Table 4. The Effect of Denosumab on the Incidence of Nonvertebral Fractures at Year 3

	Proportion of Women with Fracture (%)⁺	Absolute Risk Reduction (%)	Relative Risk Reduction (%)

	Placebo N = 3906 (%)	Denosumab N = 3902 (%)	(95% CI)	(95% CI)
Nonvertebral fracture ¹	8.0	6.5	1.5 (0.3, 2.7)	20 (5, 33)*

⁺ Event rates based on Kaplan-Meier estimates at 3 years.

¹ Excluding those of the vertebrae (cervical, thoracic, and lumbar), skull, facial, mandible, metacarpus, and finger and toe phalanges.

* p-value = 0.01.

Effect on Bone Mineral Density (BMD)

Treatment with denosumab significantly increased BMD at all anatomic sites measured at 3 years. The treatment differences in BMD at 3 years were 8.8% at the lumbar spine, 6.4% at the total hip, and 5.2% at the femoral neck. Consistent effects on BMD were observed at the lumbar spine, regardless of baseline age, race, weight/body mass index (BMI), baseline BMD, and level of bone turnover.

After denosumab discontinuation, BMD returned to approximately baseline levels within 12 months.

Bone Histology and Histomorphometry

A total of 115 transiliac crest bone biopsy specimens were obtained from 92 postmenopausal women with osteoporosis at either month 24 and/or month 36 (53 specimens in denosumab group, 62 specimens in placebo group). Of the biopsies obtained, 115 (100%) were adequate for qualitative histology and 7 (6%) were adequate for full quantitative histomorphometry assessment.

Qualitative histology assessments showed normal architecture and quality with no evidence of mineralization defects, woven bone, or marrow fibrosis in patients treated with denosumab.

The presence of double tetracycline labeling in a biopsy specimen provides an indication of active bone remodeling, while the absence of tetracycline label suggests suppressed bone formation. In patients treated with denosumab, 35% had no tetracycline label present at the month 24 biopsy and 38% had no tetracycline label present at the month 36 biopsy, while 100% of placebo-treated patients had double label present at both time points. When compared to placebo, treatment with denosumab resulted in virtually absent activation frequency and markedly reduced bone formation rates. However, the long-term consequences of this degree of suppression of bone remodeling are unknown.

14.2 Treatment to Increase Bone Mass in Men with Osteoporosis

The efficacy and safety of denosumab in the treatment to increase bone mass in men with osteoporosis was demonstrated in a 1-year, randomized, double-blind, placebo-controlled trial. Enrolled men had a baseline BMD T-score between -2.0 and -3.5 at the lumbar spine or femoral neck. Men with a BMD T-score between -1.0 and -3.5 at the lumbar spine or femoral neck were also enrolled if there was a history of prior fragility fracture. Men with other diseases (such as rheumatoid arthritis, osteogenesis imperfecta, and Paget's disease) or on therapies that may affect bone were excluded from this study. The 242 men enrolled in the study ranged in age from 31 to 84 years with a mean age of 65 years. Men were randomized to receive SC injections of either placebo (n = 121) or denosumab 60 mg (n = 121) once every 6 months. All men received at least 1000 mg calcium and at least 800 IU vitamin D supplementation daily.

Effect on Bone Mineral Density (BMD)

The primary efficacy variable was percent change in lumbar spine BMD from baseline to 1-year. Secondary efficacy variables included percent change in total hip, and femoral neck BMD from baseline to 1-year.

Treatment with denosumab significantly increased BMD at 1-year. The treatment differences in BMD at 1-year were 4.8% (+0.9% placebo, +5.7% denosumab; (95% CI: 4.0, 5.6); $p < 0.0001$) at the lumbar spine, 2.0% (+0.3% placebo, +2.4% denosumab) at the total hip, and 2.2% (0.0% placebo, +2.1% denosumab) at femoral neck. Consistent effects on BMD were observed at the lumbar spine regardless of baseline age, race, BMD, testosterone concentrations, and level of bone turnover.

Bone Histology and Histomorphometry

A total of 29 transiliac crest bone biopsy specimens were obtained from men with osteoporosis at 12 months (17 specimens in denosumab group, 12 specimens in placebo group). Of the biopsies obtained, 29 (100%) were adequate for qualitative histology and, in denosumab patients, 6 (35%) were adequate for full quantitative histomorphometry assessment. Qualitative histology assessments showed normal architecture and quality with no evidence of mineralization defects, woven bone, or marrow fibrosis in patients treated with denosumab. The presence of double tetracycline labeling in a biopsy specimen provides an indication of active bone remodeling, while the absence of tetracycline label suggests suppressed bone formation. In patients treated with denosumab, 6% had no tetracycline label present at the month 12 biopsy, while 100% of placebo-treated patients had double label present. When compared to placebo, treatment with denosumab resulted in markedly reduced bone formation rates. However, the long-term consequences of this degree of suppression of bone remodeling are unknown.

14.3 Treatment of Glucocorticoid-Induced Osteoporosis

The efficacy and safety of denosumab in the treatment of patients with glucocorticoid-induced osteoporosis was assessed in the 12-month primary analysis of a 2-year, randomized, multicenter, double-blind, parallel-group, active-controlled study (NCT 01575873) of 795 patients (70% women and 30% men) aged 20 to 94 years (mean age of 63 years) treated with greater than or equal to 7.5 mg/day oral prednisone (or equivalent) for < 3 months prior to study enrollment and planning to continue treatment for a total of at least 6 months (glucocorticoid-initiating subpopulation; $n = 290$) or ≥ 3 months prior to study enrollment and planning to continue treatment for a total of at least 6 months (glucocorticoid-continuing subpopulation, $n = 505$). Enrolled patients < 50 years of age were required to have a history of osteoporotic fracture. Enrolled patients ≥ 50 years of age who were in the glucocorticoid-continuing subpopulation were required to have a baseline BMD T-score of ≤ -2.0 at the lumbar spine, total hip, or femoral neck; or a BMD T-score ≤ -1.0 at the lumbar spine, total hip, or femoral neck and a history of osteoporotic fracture.

Patients were randomized (1:1) to receive either an oral daily bisphosphonate (active-control, risedronate 5 mg once daily) ($n = 397$) or denosumab 60 mg subcutaneously once every 6 months ($n = 398$) for one year. Randomization was stratified by gender within each subpopulation. Patients received at least 1000 mg calcium and 800 IU vitamin D supplementation daily.

Effect on Bone Mineral Density (BMD)

In the glucocorticoid-initiating subpopulation, denosumab significantly increased lumbar spine BMD compared to the active-control at one year (Active-control 0.8%, denosumab

3.8%) with a treatment difference of 2.9% ($p < 0.001$). In the glucocorticoid-continuing subpopulation, denosumab significantly increased lumbar spine BMD compared to active-control at one year (Active-control 2.3%, denosumab 4.4%) with a treatment difference of 2.2% ($p < 0.001$). Consistent effects on lumbar spine BMD were observed regardless of gender; race; geographic region; menopausal status; and baseline age, lumbar spine BMD T-score, and glucocorticoid dose within each subpopulation.

Bone Histology

Bone biopsy specimens were obtained from 17 patients (11 in the active-control treatment group and 6 in the denosumab treatment group) at Month 12. Of the biopsies obtained, 17 (100%) were adequate for qualitative histology. Qualitative assessments showed bone of normal architecture and quality without mineralization defects or bone marrow abnormality. The presence of double tetracycline labeling in a biopsy specimen provides an indication of active bone remodeling, while the absence of tetracycline label suggests suppressed bone formation. In patients treated with active-control, 100% of biopsies had tetracycline label. In patients treated with denosumab, 1 (33%) had tetracycline label and 2 (67%) had no tetracycline label present at the 12-month biopsy. Evaluation of full quantitative histomorphometry including bone remodeling rates was not possible in the glucocorticoid-induced osteoporosis population treated with denosumab. The long-term consequences of this degree of suppression of bone remodeling in glucocorticoid-treated patients is unknown.

14.4 Treatment of Bone Loss in Men with Prostate Cancer

The efficacy and safety of denosumab in the treatment of bone loss in men with nonmetastatic prostate cancer receiving androgen deprivation therapy (ADT) were demonstrated in a 3-year, randomized (1:1), double-blind, placebo-controlled, multinational study. Men less than 70 years of age had either a BMD T-score at the lumbar spine, total hip, or femoral neck between -1.0 and -4.0, or a history of an osteoporotic fracture. The mean baseline lumbar spine BMD T-score was -0.4, and 22% of men had a vertebral fracture at baseline. The 1468 men enrolled ranged in age from 48 to 97 years (median 76 years). Men were randomized to receive subcutaneous injections of either placebo ($n = 734$) or denosumab 60 mg ($n = 734$) once every 6 months for a total of 6 doses. Randomization was stratified by age (< 70 years vs. ≥ 70 years) and duration of ADT at trial entry (≤ 6 months vs. > 6 months). Seventy-nine percent of patients received ADT for more than 6 months at study entry. All men received at least 1000 mg calcium and 400 IU vitamin D supplementation daily.

Effect on Bone Mineral Density (BMD)

The primary efficacy variable was percent change in lumbar spine BMD from baseline to month 24. An additional key secondary efficacy variable was the incidence of new vertebral fracture through month 36 diagnosed based on x-ray evaluation by two independent radiologists. Lumbar spine BMD was higher at 2 years in denosumab-treated patients as compared to placebo-treated patients [-1.0% placebo, +5.6% denosumab; treatment difference 6.7% (95% CI: 6.2, 7.1); $p < 0.0001$].

With approximately 62% of patients followed for 3 years, treatment differences in BMD at 3 years were 7.9% (-1.2% placebo, +6.8% denosumab) at the lumbar spine, 5.7% (-2.6% placebo, +3.2% denosumab) at the total hip, and 4.9% (-1.8% placebo, +3.0% denosumab) at the femoral neck. Consistent effects on BMD were observed at the lumbar spine in relevant subgroups defined by baseline age, BMD, and baseline history of vertebral fracture.

Effect on Vertebral Fractures

Denosumab significantly reduced the incidence of new vertebral fractures at 3 years (p = 0.0125), as shown in Table 5.

Table 5. The Effect of Denosumab on the Incidence of New Vertebral Fractures in Men with Nonmetastatic Prostate Cancer

	Proportion of Men with Fracture (%) [†]		Absolute Risk Reduction (%) [*] (95% CI)	Relative Risk Reduction (%) [*] (95% CI)
	Placebo N = 673 (%)	Denosumab N = 679 (%)		
0-1 Year	1.9	0.3	1.6 (0.5, 2.8)	85 (33, 97)
0-2 Years	3.3	1.0	2.2 (0.7, 3.8)	69 (27, 86)
0-3 Years	3.9	1.5	2.4 (0.7, 4.1)	62 (22, 81)

[†] Event rates based on crude rates in each interval.

^{*} Absolute risk reduction and relative risk reduction based on Mantel-Haenszel method adjusting for age group and ADT duration variables.

14.5 Treatment of Bone Loss in Women with Breast Cancer

The efficacy and safety of denosumab in the treatment of bone loss in women receiving adjuvant aromatase inhibitor (AI) therapy for breast cancer was assessed in a 2-year, randomized (1:1), double-blind, placebo-controlled, multinational study. Women had baseline BMD T-scores between -1.0 to -2.5 at the lumbar spine, total hip, or femoral neck, and had not experienced fracture after age 25. The mean baseline lumbar spine BMD T-score was -1.1, and 2.0% of women had a vertebral fracture at baseline. The 252 women enrolled ranged in age from 35 to 84 years (median 59 years). Women were randomized to receive subcutaneous injections of either placebo (n = 125) or denosumab 60 mg (n = 127) once every 6 months for a total of 4 doses. Randomization was stratified by duration of adjuvant AI therapy at trial entry (≤ 6 months vs. > 6 months). Sixty-two percent of patients received adjuvant AI therapy for more than 6 months at study entry. All women received at least 1000 mg calcium and 400 IU vitamin D supplementation daily.

Effect on Bone Mineral Density (BMD)

The primary efficacy variable was percent change in lumbar spine BMD from baseline to month 12. Lumbar spine BMD was higher at 12 months in denosumab-treated patients as compared to placebo-treated patients [-0.7% placebo, +4.8% denosumab; treatment difference 5.5% (95% CI: 4.8, 6.3); p < 0.0001].

With approximately 81% of patients followed for 2 years, treatment differences in BMD at 2 years were 7.6% (-1.4% placebo, +6.2% denosumab) at the lumbar spine, 4.7% (-1.0% placebo, +3.8% denosumab) at the total hip, and 3.6% (-0.8% placebo, +2.8% denosumab) at the femoral neck.

16 HOW SUPPLIED/STORAGE AND HANDLING

How Supplied

OSVYRTI (denosumab-desu) injection is a clear and colorless to pale yellow solution supplied in a single-dose prefilled syringe with a UltraSafe Plus™ Passive safety guard. The prefilled syringe is not made with natural rubber latex.

60 mg/mL in a single-dose prefilled syringe	1 per carton	NDC 69448-021-63
---	--------------	------------------

Storage and Handling

Store OSVYRTI refrigerated at 2°C to 8°C (36°F to 46°F) in the original carton to protect

from light. Do not freeze. Prior to administration, OSVYRTI may be allowed to reach room temperature up to 25°C (77°F) in the original container. Once removed from the refrigerator, OSVYRTI must not be exposed to temperatures above 25°C (77°F) and must be used within 14 days. If not used within the 14 days, OSVYRTI should be discarded. Do not use OSVYRTI after the expiry date printed on the label.

Protect OSVYRTI from direct light and heat.

Avoid vigorous shaking of OSVYRTI.

17 PATIENT COUNSELING INFORMATION

Advise the patient to read the FDA-approved patient labeling (Medication Guide).

Hypocalcemia

Advise the patient to adequately supplement with calcium and vitamin D and instruct them on the importance of maintaining serum calcium levels while receiving OSVYRTI [*see Warnings and Precautions (5.1), Use in Specific Populations (8.6)*]. Advise patients to seek prompt medical attention if they develop signs or symptoms of hypocalcemia.

Severe Hypocalcemia in Patients with Advanced Chronic Kidney Disease

Advise patients with advanced chronic kidney disease, including those who are dialysis-dependent, about the symptoms of hypocalcemia and the importance of maintaining serum calcium levels with adequate calcium and activated vitamin D supplementation. Advise these patients to have their serum calcium measured weekly for the first month after OSVYRTI administration and monthly thereafter. [*see Dosage and Administration (2.2), Warnings and Precautions (5.1), Use in Specific Populations (8.6)*]

Drug Products with Same Active Ingredient

Advise patients that if they receive OSVYRTI, they should not receive other denosumab products concomitantly [*see Warnings and Precautions (5.2)*].

Hypersensitivity

Advise patients to seek prompt medical attention if signs or symptoms of hypersensitivity reactions occur. Advise patients who have had signs or symptoms of systemic hypersensitivity reactions that they should not receive denosumab products [*see Warnings and Precautions (5.3), Contraindications (4)*].

Osteonecrosis of the Jaw

Advise patients to maintain good oral hygiene during treatment with OSVYRTI and to inform their dentist prior to dental procedures that they are receiving OSVYRTI. Patients should inform their physician or dentist if they experience persistent pain and/or slow healing of the mouth or jaw after dental surgery [*see Warnings and Precautions (5.4)*].

Atypical Subtrochanteric and Diaphyseal Femoral Fractures

Advise patients to report new or unusual thigh, hip, or groin pain [*see Warnings and Precautions (5.5)*].

Multiple Vertebral Fractures (MVF) Following Treatment Discontinuation

Advise patients not to interrupt OSVYRTI therapy without talking to their physician [*see Warnings and Precautions (5.6)*].

Serious Infections

Advise patients to seek prompt medical attention if they develop signs or symptoms of infections, including cellulitis [*see Warnings and Precautions (5.7)*].

Dermatologic Adverse Reactions

Advise patients to seek prompt medical attention if they develop signs or symptoms of dermatological reactions (such as dermatitis, rashes, and eczema) [*see Warnings and Precautions (5.8)*].

Musculoskeletal Pain

Inform patients that severe bone, joint, and/or muscle pain have been reported in patients taking denosumab products. Patients should report severe symptoms if they develop [*see Warnings and Precautions (5.9)*].

Pregnancy/Nursing

Counsel females of reproductive potential to use effective contraceptive measure to prevent pregnancy during treatment and for at least 5 months after the last dose of OSVYRTI. Advise the patient to contact their physician immediately if pregnancy does occur during these times. Advise patients not to take OSVYRTI while pregnant or breastfeeding. If a patient wishes to start breastfeeding after treatment, advise her to discuss the appropriate timing with her physician [*see Contraindications (4), Use in Specific Populations (8.1)*].

Schedule of Administration

Advise patients that if a dose of OSVYRTI is missed, the injection should be administered as soon as convenient. Thereafter, schedule injections every 6 months from the date of the last injection.



OSVYRTI (denosumab-desu)

Manufactured by:

Accord BioPharma Inc.
8041 Arco Corporate Drive, Suite 200,
Raleigh, NC 27617 USA
U.S. License No. 2105

UltraSafe Plus™ Passive needle guard is a trademark of Becton, Dickinson and Company.

Medication Guide
OSVYRTI (ozz-VER-tee)

(denosumab-desu)
Injection, for subcutaneous use

What is the most important information I should know about OSVYRTI?

If you receive OSVYRTI, you should not receive other denosumab products at the same time.

OSVYRTI can cause serious side effects including:

- **Increased risk of severe low calcium levels in your blood (hypocalcemia).** OSVYRTI may lower the calcium levels in your blood. If you have low blood calcium before you start receiving OSVYRTI, it may get worse during treatment. Your low blood calcium must be treated before you receive OSVYRTI. Talk to your doctor before starting OSVYRTI. Your doctor may prescribe calcium and vitamin D to help prevent low calcium levels in your blood while you take OSVYRTI. Take calcium and vitamin D as your doctor tells you to.
If you have advanced chronic kidney disease (may or may not be on kidney dialysis), OSVYRTI may increase your risk for severe low calcium levels in your blood, which could result in hospitalization, life-threatening events and death. A mineral and bone disorder associated with kidney disease called chronic kidney disease-mineral bone disorder (CKD-MBD) may increase your risk for severe low calcium levels in blood. Before you start OSVYRTI and during treatment, your doctor may need to do certain blood tests to check for CKD-MBD.
Most people with low blood calcium levels do not have symptoms, but some people may have symptoms. Call your doctor right away if you have symptoms of low blood calcium such as:
 - spasms, twitches, or cramps in your muscles
 - numbness or tingling in your fingers, toes, or around your mouth
- **Serious allergic reactions.** Serious allergic reactions have happened in people who take denosumab products. Call your doctor or go to your nearest emergency room right away if you have any symptoms of a serious allergic reaction. Symptoms of a serious allergic reaction may include:
 - low blood pressure (hypotension)
 - rash
 - trouble breathing
 - itching
 - throat tightness
 - hives
 - swelling of your face, lips, or tongue
- **Severe jaw bone problems (osteonecrosis).** Severe jaw bone problems may happen when you take OSVYRTI. Your doctor should examine your mouth before you start OSVYRTI. Your doctor may tell you to see your dentist before you start OSVYRTI. It is important for you to practice good mouth care during treatment with OSVYRTI. Ask your doctor or dentist about good mouth care if you have any questions.
- **Unusual thigh bone fractures.** Some people have developed unusual fractures in their thigh bone. Symptoms of a fracture include new or unusual pain in your hip, groin, or thigh.
- **Increased risk of broken bones, including broken bones in the spine, after stopping, skipping or delaying OSVYRTI.** Talk with your doctor before starting OSVYRTI treatment. After your treatment with OSVYRTI is stopped, or if you skip or delay taking a dose, your risk for breaking bones, including bones in your spine, is increased. Your risk for having more than 1 broken bone in your spine is increased if you have already had a broken bone in your spine. Do not stop, skip or delay taking OSVYRTI without first talking with your doctor. If your OSVYRTI treatment is stopped, talk to your doctor about other medicine that you can take.
- **Serious infections.** Serious infections in your skin, lower stomach area (abdomen), bladder, or ear may happen if you take OSVYRTI. Inflammation of the inner lining of the heart (endocarditis) due to an infection also may happen more often in people who take OSVYRTI. You may need to go to the hospital for treatment if you develop an infection.
OSVYRTI is a medicine that may affect the ability of your body to fight infections. People who have a weakened immune system or take medicines that affect the immune system may have an increased risk for developing serious infections. Call your doctor right away if you have any of the following symptoms of infection:
 - fever or chills
 - skin that looks red or swollen and is hot or tender to touch
 - fever, shortness of breath, cough that will not go away
 - severe abdominal pain

- frequent or urgent need to urinate or burning feeling when you urinate
- **Skin problems.** Skin problems such as inflammation of your skin (dermatitis), rash, and eczema may happen if you take OSVYRTI. Call your doctor if you have any of the following symptoms of skin problems that do not go away or get worse:
 - redness
 - itching
 - small bumps or patches (rash)
 - your skin is dry or feels like leather
 - blisters that ooze or become crusty
 - skin peeling
- **Bone, joint, or muscle pain.** Some people who take denosumab products develop severe bone, joint, or muscle pain.

Call your doctor right away if you have any of these side effects.

What is OSVYRTI?

OSVYRTI is a prescription medicine used to:

- Treat osteoporosis (thinning and weakening of bone) in women after menopause (“change of life”) who:
 - are at high risk for fracture (broken bone)
 - cannot use another osteoporosis medicine or other osteoporosis medicines did not work well
- Increase bone mass in men with osteoporosis who are at high risk for fracture.
- Treat osteoporosis in men and women who will be taking corticosteroid medicines (such as prednisone) for at least 6 months and are at high risk for fracture.
- Treat bone loss in men who are at high risk for fracture receiving certain treatments for prostate cancer that has not spread to other parts of the body.
- Treat bone loss in women who are at high risk for fracture receiving certain treatments for breast cancer that has not spread to other parts of the body.

It is not known if OSVYRTI is safe and effective in children. OSVYRTI is not approved for use in children.

Do not take OSVYRTI if you:

- have been told by your doctor that your blood calcium level is too low.
- are pregnant or plan to become pregnant.
- are allergic to denosumab products or any of the ingredients in OSVYRTI. See the end of this Medication Guide for a complete list of ingredients in OSVYRTI.

Before taking OSVYRTI, tell your doctor about all of your medical conditions, including if you:

- are taking other denosumab products.
- have low blood calcium.
- cannot take daily calcium and vitamin D.
- had parathyroid or thyroid surgery (glands located in your neck).
- have been told you have trouble absorbing minerals in your stomach or intestines (malabsorption syndrome).
- have kidney problems or are on kidney dialysis.
- are taking medicine that can lower your blood calcium levels.
- plan to have dental surgery or teeth removed.
- are pregnant or plan to become pregnant. OSVYRTI may harm your unborn baby.

Females who are able to become pregnant:

- Your healthcare provider should do a pregnancy test before you start treatment with OSVYRTI.
- You should use an effective method of birth control (contraception) during treatment with OSVYRTI and for at least 5 months after your last dose of OSVYRTI.
- Tell your doctor right away if you become pregnant while taking OSVYRTI.
- are breastfeeding or plan to breastfeed. It is not known if OSVYRTI passes into your breast milk. You and your doctor should decide if you will take OSVYRTI or breastfeed. You should not do both.

Tell your doctor about all the medicines you take, including prescription and over-the-counter medicines, vitamins, and herbal supplements.

Know the medicines you take. Keep a list of medicines with you to show to your doctor or pharmacist when you get a new medicine.

How will I receive OSVYRTI?

- OSVYRTI is an injection that will be given to you by a healthcare provider. OSVYRTI is injected under your skin (subcutaneous).
- You will receive OSVYRTI 1 time every 6 months.
- You should take calcium and vitamin D as your doctor tells you to while you receive OSVYRTI.

- If you miss a dose of OSVYRTI, you should receive your injection as soon as you can.
- Take good care of your teeth and gums while you receive OSVYRTI. Brush and floss your teeth regularly.
- Tell your dentist that you are receiving OSVYRTI before you have dental work.

What are the possible side effects of OSVYRTI?

OSVYRTI may cause serious side effects.

- See “What is the most important information I should know about OSVYRTI?”
- It is not known if the use of OSVYRTI over a long period of time may cause slow healing of broken bones.

The most common side effects of OSVYRTI in women who are being treated for osteoporosis after menopause are:

- back pain
- pain in your arms and legs
- high cholesterol
- muscle pain
- bladder infection

The most common side effects of OSVYRTI in men with osteoporosis are:

- back pain
- joint pain
- common cold (runny nose or sore throat)

The most common side effects of OSVYRTI in patients with glucocorticoid-induced osteoporosis are:

- back pain
- high blood pressure
- lung infection (bronchitis)
- headache

The most common side effects of OSVYRTI in patients receiving certain treatments for prostate or breast cancer are:

- joint pain
- back pain
- pain in your arms and legs
- muscle pain

Tell your doctor if you have any side effect that bothers you or that does not go away. These are not all the possible side effects of OSVYRTI.

Call your doctor for medical advice about side effects. You may report side effects to FDA at 1-800-FDA-1088

How should I store OSVYRTI if I need to pick it up from a pharmacy?

- Keep OSVYRTI refrigerated at 36°F to 46°F (2°C to 8°C) in the original carton.
- Do not freeze OSVYRTI.
- When you remove OSVYRTI from the refrigerator, OSVYRTI must be kept at room temperature up to 77°F (25°C) in the original carton and must be used within 14 days.
- Do not keep OSVYRTI at temperatures above 77°F (25°C). Warm temperatures will affect how OSVYRTI works.
- Do not shake OSVYRTI.
- Keep OSVYRTI in the original carton to protect from light.

Keep OSVYRTI and all medicines out of the reach of children.

General information about the safe and effective use of OSVYRTI.

Medicines are sometimes prescribed for purposes other than those listed in a Medication Guide. Do not use OSVYRTI for a condition for which it was not prescribed. Do not give OSVYRTI to other people, even if they have the same symptoms that you have. It may harm them. You can ask your doctor or pharmacist for information about OSVYRTI that is written for healthcare provider.

What are the ingredients in OSVYRTI?

Active ingredient: denosumab-desu

Inactive ingredients: glacial acetic acid, polysorbate 20, sodium hydroxide, sorbitol, and Water for Injection

accord BioPharma™

Manufactured by: Accord BioPharma Inc., 8041 Arco Corporate Drive, Suite 200, Raleigh, NC 27617 USA, U.S. License No. 2105

HIGHLIGHTS OF PRESCRIBING INFORMATION

These highlights do not include all the information needed to use JUBEREQ safely and effectively. See full prescribing information for JUBEREQ.

JUBEREQ (denosumab-desu) injection, for subcutaneous use
Initial U.S. Approval: 2025

JUBEREQ (denosumab-desu) is biosimilar* to XGEVA® (denosumab).

INDICATIONS AND USAGE

Jubereq is a RANK ligand (RANKL) inhibitor indicated for:

- Prevention of skeletal-related events in patients with multiple myeloma and in patients with bone metastases from solid tumors. (1.1)
- Treatment of adults and skeletally mature adolescents with giant cell tumor of bone that is unresectable or where surgical resection is likely to result in severe morbidity. (1.2, 14.3)
- Treatment of hypercalcemia of malignancy refractory to bisphosphonate therapy. (1.3)

DOSAGE AND ADMINISTRATION

- Jubereq should be administered by a healthcare provider. (2.1)
- Jubereq is intended for subcutaneous route only and should not be administered intravenously, intramuscularly, or intradermally. (2.1)
- Multiple Myeloma and Bone Metastasis from Solid Tumors: Administer 120 mg every 4 weeks as a subcutaneous injection in the upper arm, upper thigh, or abdomen. (2.2)
- Giant Cell Tumor of Bone: Administer 120 mg every 4 weeks with additional 120 mg doses on Days 8 and 15 of the first month of therapy. Administer subcutaneously in the upper arm, upper thigh, or abdomen. (2.3)
- Administer calcium and vitamin D as necessary to treat or prevent hypocalcemia. (2.2, 2.3)
- Hypercalcemia of Malignancy: Administer 120 mg every 4 weeks with additional 120 mg doses on Days 8 and 15 of the first month of therapy. Administer subcutaneously in the upper arm, upper thigh, or abdomen. (2.4)

DOSAGE FORMS AND STRENGTHS

- Injection: 120 mg/1.7 mL (70 mg/mL) solution in a single-dose vial (3)

CONTRAINDICATIONS

- Hypocalcemia (4.1)
- Known clinically significant hypersensitivity to denosumab products (4.2)

WARNINGS AND PRECAUTIONS

- Drug Products with Same Active Ingredient: Patients receiving Jubereq should not receive other denosumab products concomitantly. (5.1)
- Hypersensitivity reactions including anaphylaxis may occur. Discontinue permanently if a clinically significant reaction occurs. (5.2)
- Hypocalcemia: Denosumab products can cause severe symptomatic hypocalcemia. Fatal cases have been reported with denosumab products use. Correct hypocalcemia prior to initiating Jubereq. Monitor calcium levels during therapy, especially in the first weeks of initiating therapy, and adequately supplement all patients with calcium and vitamin D. (5.3)

- Osteonecrosis of the jaw (ONJ) has been reported in patients receiving denosumab products. Perform an oral examination prior to starting Jubereq. Monitor for symptoms. Avoid invasive dental procedures during treatment with Jubereq. (5.4)
- Atypical femoral fracture: Evaluate patients with thigh or groin pain to rule out a femoral fracture. (5.5)
- Hypercalcemia Following Treatment Discontinuation in Patients with Giant Cell Tumor of Bone and in Patients with Growing Skeletons: Monitor patients for signs and symptoms of hypercalcemia, and manage as clinically appropriate. (5.6, 8.4)
- Multiple Vertebral Fractures (MVF) Following Treatment Discontinuation: When Jubereq treatment is discontinued, evaluate the individual patient's risk for vertebral fractures. (5.7)
- Embryo-Fetal Toxicity: Can cause fetal harm. Advise females of reproductive potential of potential risk to the fetus and to use effective contraception. (5.8, 8.1, 8.3)

ADVERSE REACTIONS

- Bone Metastasis from Solid Tumors: Most common adverse reactions ($\geq 25\%$) were fatigue/asthenia, hypophosphatemia, and nausea. (6.1)
- Multiple Myeloma: Most common adverse reactions ($\geq 10\%$) were diarrhea, nausea, anemia, back pain, thrombocytopenia, peripheral edema, hypocalcemia, upper respiratory tract infection, rash, and headache. (6.1)
- Giant Cell Tumor of Bone: Most common adverse reactions ($\geq 10\%$) were arthralgia, headache, nausea, back pain, fatigue, and pain in extremity. (6.1)
- Hypercalcemia of Malignancy: Most common adverse reactions ($> 20\%$) were nausea, dyspnea, decreased appetite, headache, peripheral edema, vomiting, anemia, constipation, and diarrhea. (6.1)

To report SUSPECTED ADVERSE REACTIONS, contact Accord BioPharma Inc. at 1-866-941-7875 or FDA at 1-800-FDA-1088 or www.fda.gov/medwatch.

USE IN SPECIFIC POPULATIONS

- Pediatric patients: Recommended only for treatment of skeletally mature adolescents with giant cell tumor of bone. (8.4)
- Renal impairment: Patients with creatinine clearance less than 30 mL/min or receiving dialysis are at risk for hypocalcemia. Adequately supplement with calcium and vitamin D. (8.6)

See 17 for PATIENT COUNSELING INFORMATION.

*Biosimilar means that the biological product is approved based on data demonstrating that it is highly similar to an FDA-approved biological product, known as a reference product, and that there are no clinically meaningful differences between the biosimilar product and the reference product. Biosimilarity of JUBEREQ has been demonstrated for the condition(s) of use (e.g. indication(s), dosing regimen(s)), strength(s), dosage form(s), and route(s) of administration described in its Full Prescribing Information.

Revised: 10/2025

FULL PRESCRIBING INFORMATION: CONTENTS*

- 1 INDICATIONS AND USAGE**
 - 1.1 Multiple Myeloma and Bone Metastasis from Solid Tumors
 - 1.2 Giant Cell Tumor of Bone
 - 1.3 Hypercalcemia of Malignancy
- 2 DOSAGE AND ADMINISTRATION**
 - 2.1 Important Administration Instructions
 - 2.2 Multiple Myeloma and Bone Metastasis from Solid Tumors
 - 2.3 Giant Cell Tumor of Bone
 - 2.4 Hypercalcemia of Malignancy
 - 2.5 Preparation and Administration
- 3 DOSAGE FORMS AND STRENGTHS**
- 4 CONTRAINDICATIONS**
 - 4.1 Hypocalcemia
 - 4.2 Hypersensitivity
- 5 WARNINGS AND PRECAUTIONS**
 - 5.1 Drug Products with Same Active Ingredient
 - 5.2 Hypersensitivity
 - 5.3 Hypocalcemia
 - 5.4 Osteonecrosis of the Jaw (ONJ)
 - 5.5 Atypical Subtrochanteric and Diaphyseal Femoral Fracture
 - 5.6 Hypercalcemia Following Treatment Discontinuation in Patients with Giant Cell Tumor of Bone and in Patients with Growing Skeletons
 - 5.7 Multiple Vertebral Fractures (MVF) Following Treatment Discontinuation
 - 5.8 Embryo-Fetal Toxicity

- 6 ADVERSE REACTIONS**
 - 6.1 Clinical Trials Experience
 - 6.2 Postmarketing Experience
- 8 USE IN SPECIFIC POPULATIONS**
 - 8.1 Pregnancy
 - 8.2 Lactation
 - 8.3 Females and Males of Reproductive Potential
 - 8.4 Pediatric Use
 - 8.5 Geriatric Use
 - 8.6 Renal Impairment
- 10 OVERDOSAGE**
- 11 DESCRIPTION**
- 12 CLINICAL PHARMACOLOGY**
 - 12.1 Mechanism of Action
 - 12.2 Pharmacodynamics
 - 12.3 Pharmacokinetics
 - 12.6 Immunogenicity
- 13 NONCLINICAL TOXICOLOGY**
 - 13.1 Carcinogenesis, Mutagenesis, Impairment of Fertility
 - 13.2 Animal Toxicology and/or Pharmacology
- 14 CLINICAL TRIALS**
 - 14.1 Bone Metastasis from Solid Tumors
 - 14.2 Multiple Myeloma
 - 14.3 Giant Cell Tumor of Bone
 - 14.4 Hypercalcemia of Malignancy
- 16 HOW SUPPLIED/STORAGE AND HANDLING**
- 17 PATIENT COUNSELING INFORMATION**

* Sections or subsections omitted from the full prescribing information are not listed.

FULL PRESCRIBING INFORMATION

1 INDICATIONS AND USAGE

1.1 Multiple Myeloma and Bone Metastasis from Solid Tumors

Jubereq is indicated for the prevention of skeletal-related events in patients with multiple myeloma and in patients with bone metastases from solid tumors.

1.2 Giant Cell Tumor of Bone

Jubereq is indicated for the treatment of adults and skeletally mature adolescents with giant cell tumor of bone that is unresectable or where surgical resection is likely to result in severe morbidity [*see Clinical Trials (14.2)*].

1.3 Hypercalcemia of Malignancy

Jubereq is indicated for the treatment of hypercalcemia of malignancy refractory to bisphosphonate therapy.

2 DOSAGE AND ADMINISTRATION

2.1 Important Administration Instructions

Jubereq should be administered by a healthcare provider.

Jubereq is intended for subcutaneous route only and should not be administered intravenously, intramuscularly, or intradermally.

2.2 Multiple Myeloma and Bone Metastasis from Solid Tumors

The recommended dose of Jubereq is 120 mg administered as a subcutaneous injection every 4 weeks in the upper arm, upper thigh, or abdomen.

Administer calcium and vitamin D as necessary to treat or prevent hypocalcemia [*see Warnings and Precautions (5.3)*].

2.3 Giant Cell Tumor of Bone

The recommended dose of Jubereq is 120 mg administered every 4 weeks with additional 120 mg doses on Days 8 and 15 of the first month of therapy. Administer subcutaneously in the upper arm, upper thigh, or abdomen.

Administer calcium and vitamin D as necessary to treat or prevent hypocalcemia [*see Warnings and Precautions (5.3)*].

2.4 Hypercalcemia of Malignancy

The recommended dose of Jubereq is 120 mg administered every 4 weeks with additional 120 mg doses on Days 8 and 15 of the first month of therapy. Administer subcutaneously in the upper arm, upper thigh, or abdomen.

2.5 Preparation and Administration

Parenteral drug products should be inspected visually for particulate matter and discoloration prior to administration, whenever solution and container permit. Jubereq is a clear, colorless to pale yellow solution. Do not use if the solution is discolored or cloudy or if the solution contains particles or foreign particulate matter.

Prior to administration, Jubereq may be removed from the refrigerator and brought to room temperature up to 25°C (77°F) by standing in the original container. This generally takes 15 to 30 minutes. Do not warm Jubereq in any other way [*see How Supplied/Storage and Handling (16)*].

Use a 27-gauge needle to withdraw and inject the entire contents of the vial. Do not re-enter the vial. Discard vial after single entry.

3 DOSAGE FORMS AND STRENGTHS

Injection: 120 mg/1.7 mL (70 mg/mL) clear, colorless to pale yellow solution in a single-dose vial.

4 CONTRAINDICATIONS

4.1 Hypocalcemia

Pre-existing hypocalcemia must be corrected prior to initiating therapy with Jubereq [*see Warnings and Precautions (5.3)*].

4.2 Hypersensitivity

Jubereq is contraindicated in patients with known clinically significant hypersensitivity to denosumab products [*see Warnings and Precautions (5.2) and Adverse Reactions (6.2)*].

5 WARNINGS AND PRECAUTIONS

5.1 Drug Products with Same Active Ingredient

Patients receiving Jubereq should not receive other denosumab products concomitantly.

5.2 Hypersensitivity

Clinically significant hypersensitivity including anaphylaxis has been reported with use of denosumab products. Reactions may include hypotension, dyspnea, upper airway edema, lip swelling, rash, pruritus, and urticaria. If an anaphylactic or other clinically significant allergic reaction occurs, initiate appropriate therapy and discontinue Jubereq therapy permanently [*see Contraindications (4.2) and Adverse Reactions (6.2)*].

5.3 Hypocalcemia

Denosumab products can cause severe symptomatic hypocalcemia, and fatal cases have been reported. Correct pre-existing hypocalcemia prior to Jubereq treatment. Monitor calcium levels, throughout Jubereq therapy, especially in the first weeks of initiating therapy, and administer calcium, magnesium, and vitamin D as necessary. Concomitant use of calcimimetics and other drugs that can lower calcium levels may worsen hypocalcemia risk and serum calcium should be closely monitored. Advise patients to contact a healthcare provider for symptoms of hypocalcemia [*see Contraindications (4.1), Adverse Reactions (6.1, 6.2), and Patient Counseling Information (17)*].

An increased risk of hypocalcemia has been observed in clinical trials of patients with increasing renal dysfunction, most commonly with severe dysfunction (creatinine clearance less than 30 mL/min and/or on dialysis), and with inadequate/no calcium supplementation. Monitor calcium levels and calcium and vitamin D intake [*see Adverse Reactions (6.1), Use in Specific Populations (8.6), and Clinical Pharmacology (12.3)*].

5.4 Osteonecrosis of the Jaw (ONJ)

Osteonecrosis of the jaw (ONJ) has been reported in patients receiving denosumab products, manifesting as jaw pain, osteomyelitis, osteitis, bone erosion, tooth or periodontal infection, toothache, gingival ulceration, or gingival erosion. Persistent pain or slow healing of the mouth or jaw after dental surgery may also be manifestations of ONJ. In clinical trials in patients with cancer, the incidence of ONJ was higher with longer duration of exposure [*see Adverse Reactions (6.1)*]. Seventy-nine percent of patients with ONJ had a history of tooth extraction, poor oral hygiene, or use of a dental appliance as a predisposing factor. Other risk factors for the development of ONJ include immunosuppressive therapy, treatment with angiogenesis inhibitors, systemic corticosteroids, diabetes, and gingival infections. Similarly, for denosumab-treated patients with multiple myeloma that developed ONJ, 58% had a history of invasive dental procedures as a predisposing factor.

Perform an oral examination and appropriate preventive dentistry prior to the initiation of Jubereq and periodically during Jubereq therapy. Advise patients regarding oral hygiene practices. Avoid invasive dental procedures during treatment with Jubereq. Consider temporary discontinuation of Jubereq therapy if an invasive dental procedure must be performed. There are no data available to suggest the optimal

duration of treatment interruption.

Patients who are suspected of having or who develop ONJ while on Jubereq should receive care by a dentist or an oral surgeon. In these patients, extensive dental surgery to treat ONJ may exacerbate the condition. Clinical judgment of the treating healthcare provider should guide the management plan of each patient based on individual risk/benefit assessment.

5.5 Atypical Subtrochanteric and Diaphyseal Femoral Fracture

Atypical femoral fracture has been reported with denosumab products [*see Adverse Reactions (6.1)*]. These fractures can occur anywhere in the femoral shaft from just below the lesser trochanter to above the supracondylar flare and are transverse or short oblique in orientation without evidence of comminution.

Atypical femoral fractures most commonly occur with minimal or no trauma to the affected area. They may be bilateral and many patients report prodromal pain in the affected area, usually presenting as dull, aching thigh pain, weeks to months before a complete fracture occurs. A number of reports note that patients were also receiving treatment with glucocorticoids (e.g. prednisone) at the time of fracture.

During Jubereq treatment, patients should be advised to report new or unusual thigh, hip, or groin pain. Any patient who presents with thigh or groin pain should be suspected of having an atypical fracture and should be evaluated to rule out an incomplete femur fracture. Patient presenting with an atypical femur fracture should also be assessed for symptoms and signs of fracture in the contralateral limb. Interruption of Jubereq therapy should be considered, pending a risk/benefit assessment, on an individual basis.

5.6 Hypercalcemia Following Treatment Discontinuation in Patients with Giant Cell Tumor of Bone and in Patients with Growing Skeletons

Clinically significant hypercalcemia requiring hospitalization and complicated by acute renal injury has been reported in denosumab product-treated patients with giant cell tumor of bone and patients with growing skeletons. Hypercalcemia has been reported within the first year after treatment discontinuation. After treatment is discontinued, monitor patients for signs and symptoms of hypercalcemia, assess serum calcium periodically, reevaluate the patient's calcium and vitamin D supplementation requirements and manage patients as clinically appropriate [*see Adverse Reactions (6) and Use in Specific Populations (8.4)*].

5.7 Multiple Vertebral Fractures (MVF) Following Treatment Discontinuation

Multiple vertebral fractures (MVF) have been reported following discontinuation of treatment with denosumab products. Patients at higher risk for MVF include those with risk factors for or a history of osteoporosis or prior fractures.

When Jubereq treatment is discontinued, evaluate the individual patient's risk for vertebral fractures [*see Patient Counseling Information (17)*].

5.8 Embryo-Fetal Toxicity

Based on data from animal studies and its mechanism of action, denosumab products can cause fetal harm when administered to a pregnant woman. In animal reproduction studies, administration of denosumab to cynomolgus monkeys throughout pregnancy at a dose 25-fold higher than the recommended human dose of denosumab based on body weight resulted in increased fetal loss, stillbirths, and postnatal mortality, along with evidence of absent peripheral lymph nodes, abnormal bone growth and decreased neonatal growth.

Verify the pregnancy status of females of reproductive potential prior to the initiation of Jubereq. Advise pregnant women and females of reproductive potential that exposure to Jubereq during pregnancy or within 5 months prior to conception can result in fetal harm. Advise females of reproductive potential to use effective contraception during therapy, and for at least 5 months after the last dose of Jubereq [*see Use in Specific Populations (8.1, 8.3) and Clinical Pharmacology (12.1)*].

6 ADVERSE REACTIONS

The following adverse reactions are discussed below and elsewhere in the labeling:

- Hypersensitivity [*see Warnings and Precautions (5.2)*]
- Hypocalcemia [*see Warnings and Precautions (5.3) and Use in Specific Populations (8.6)*]
- Osteonecrosis of the Jaw [*see Warnings and Precautions (5.4)*]
- Atypical Subtrochanteric and Diaphyseal Femoral Fracture [*see Warnings and Precautions (5.5)*]
- Hypercalcemia following treatment discontinuation in patients with giant cell tumor of bone and in patients with growing skeletons [*see Warnings and Precautions (5.6) and Use in Specific Populations (8.4)*]
- Multiple vertebral fractures (MVF) following treatment discontinuation [*see Warnings and Precautions (5.7)*]

6.1 Clinical Trials Experience

Because clinical trials are conducted under widely varying conditions, adverse reaction rates observed in the clinical trials of a drug cannot be directly compared to rates in the clinical trials of another drug and may not reflect the rates observed in practice.

Bone Metastasis from Solid Tumors

The safety of denosumab was evaluated in three randomized, double-blind, double-dummy trials [*see*

Clinical Trials (14.1)] in which a total of 2841 patients with bone metastasis from prostate cancer, breast cancer, or other solid tumors, or lytic bony lesions from multiple myeloma received at least one dose of denosumab. In Studies 20050136, 20050244, and 20050103, patients were randomized to receive either 120 mg of denosumab every 4 weeks as a subcutaneous injection or 4 mg (dose adjusted for reduced renal function) of zoledronic acid every 4 weeks by intravenous (IV) infusion. Entry criteria included serum calcium (corrected) from 8 to 11.5 mg/dL (2 to 2.9 mmol/L) and creatinine clearance 30 mL/min or greater. Patients who had received IV bisphosphonates were excluded, as were patients with prior history of ONJ or osteomyelitis of the jaw, an active dental or jaw condition requiring oral surgery, non-healed dental/oral surgery, or any planned invasive dental procedure. During the study, serum chemistries including calcium and phosphorus were monitored every 4 weeks. Calcium and vitamin D supplementation was recommended but not required.

The median duration of exposure to denosumab was 12 months (range: 0.1-41) and median duration on-study was 13 months (range: 0.1-41). Of patients who received denosumab, 46% were female. Eighty-five percent were White, 5% Hispanic/Latino, 6% Asian, and 3% Black. The median age was 63 years (range: 18-93). Seventy-five percent of patients who received denosumab received concomitant chemotherapy.

The most common adverse reactions in patients (incidence greater than or equal to 25%) were fatigue/asthenia, hypophosphatemia, and nausea (see Table 1). The most common serious adverse reaction was dyspnea. The most common adverse reactions resulting in discontinuation of denosumab were osteonecrosis and hypocalcemia.

**Table 1. Selected^a Adverse Reactions of Any Severity
(Studies 20050136, 20050244, and 20050103)**

Body System	Denosumab n = 2841 %	Zoledronic Acid n = 2836 %
GASTROINTESTINAL		
Nausea	31	32
Diarrhea	20	19
GENERAL		
Fatigue/Asthenia	45	46
INVESTIGATIONS		
Hypocalcemia ^b	18	9
Hypophosphatemia ^b	32	20
NEUROLOGICAL		
Headache	13	14
RESPIRATORY		
Dyspnea	21	18

Cough	15	15
-------	----	----

^a Adverse reactions reported in at least 10% of patients receiving denosumab in Studies 20050136, 20050244, and 20050103, and meeting one of the following criteria:

- At least 1% greater incidence in denosumab-treated patients, or
- Between-group difference (either direction) of less than 1% and more than 5% greater incidence in patients treated with zoledronic acid compared to placebo (US Prescribing Information for zoledronic acid)

^b Laboratory-derived and below the central laboratory lower limit of normal [8.3 -8.5 mg/dL (2.075 -2.125 mmol/L) for calcium and 2.2 -2.8 mg/dL (0.71 -0.9 mmol/L) for phosphorus]

Severe Mineral/Electrolyte Abnormalities

- Severe hypocalcemia (corrected serum calcium less than 7 mg/dL or less than 1.75 mmol/L) occurred in 3.1% of patients treated with denosumab and 1.3% of patients treated with zoledronic acid. Of patients who experienced severe hypocalcemia, 33% experienced 2 or more episodes of severe hypocalcemia and 16% experienced 3 or more episodes [*see Warnings and Precautions (5.3) and Use in Specific Populations (8.6)*].
- Severe hypophosphatemia (serum phosphorus less than 2 mg/dL or less than 0.6 mmol/L) occurred in 15% of patients treated with denosumab and 7% of patients treated with zoledronic acid.

Osteonecrosis of the Jaw (ONJ)

In the primary treatment phases of Studies 20050136, 20050244, and 20050103, ONJ was confirmed in 1.8% of patients in the denosumab group (median exposure of 12.0 months; range: 0.1-41) and 1.3% of patients in the zoledronic acid group. The trials in patients with breast (Study 20050136) or prostate (Study 20050103) cancer included an open-label extension treatment phase where patients were offered denosumab 120 mg once every 4 weeks (median overall exposure of 14.9 months; range: 0.1-67.2). The patient-year adjusted incidence (number of events per 100 patient years) of confirmed ONJ was 1.1% during the first year of treatment, 3.7% in the second year, and 4.6% per year thereafter. The median time to ONJ was 20.6 months (range: 4-53) [*see Warnings and Precautions (5.4)*].

In a placebo-controlled clinical trial with an extension treatment phase evaluating denosumab for the prevention of bone metastases in patients with non-metastatic prostate cancer (a patient population for which denosumab is not indicated), with longer treatment exposure of up to 7 years, the patient-year adjusted incidence (number of events per 100 patient years) of confirmed ONJ was 1.1% during the first year of treatment, 3% in the second year, and 7% per year thereafter.

Atypical Subtrochanteric and Diaphyseal Fracture

In the clinical trial program, atypical femoral fracture has been reported in patients treated with denosumab and the risk increased with longer duration of treatment. Events have occurred during treatment and after treatment was discontinued [*see Warnings and Precautions (5.5)*].

Multiple Myeloma

The safety of denosumab was evaluated in an international, randomized (1:1), double-blind, active-controlled trial of patients with newly diagnosed multiple myeloma with treatment through disease progression [see *Clinical Trials (14.2)*]. In this trial, patients received 120 mg denosumab every 4 weeks as a subcutaneous injection (n = 850) or 4 mg (dose adjusted for renal function) of zoledronic acid intravenously (IV) every 4 weeks by IV infusion (n = 852). Entry criteria included serum calcium (corrected) from 8 to 11.5 mg/dL (2 to 2.9 mmol/L) and creatinine clearance 30 mL/min or greater. Patients who had received IV bisphosphonates were excluded, as were patients with prior history of ONJ or osteomyelitis of the jaw, an active dental or jaw condition requiring oral surgery, non-healed dental/oral surgery, or any planned invasive dental procedure. During the study, serum chemistries including calcium and phosphorus were monitored every 4 weeks. Calcium and vitamin D supplementation was recommended but not required.

The median duration of exposure to denosumab was 16 months (range: 1-50) and median duration on-study was 17 months (range: 0-49). Of patients who received denosumab, 46% were female, 83% percent were White, 13% Asian, 3% Black or African American, and 4% Hispanic/Latino. The median age of the patients randomized to denosumab was 63 years (range: 29-91) and all patients who received denosumab received concomitant anti-myeloma chemotherapy.

The adverse reaction profile of denosumab in patients with multiple myeloma, Study 20090482, was similar to that observed in Studies 20050136, 20050244, and 20050103. The most common adverse reactions (incidence $\geq 10\%$) were diarrhea (34%), nausea (32%), anemia (22%), back pain (21%), thrombocytopenia (19%), peripheral edema (17%), hypocalcemia (16%), upper respiratory tract infection (15%), rash (14%), and headache (11%). The most common serious adverse reaction (incidence $\geq 5\%$) was pneumonia (8%). The most common adverse reaction resulting in discontinuation of denosumab ($\geq 1\%$) was osteonecrosis of the jaw.

Hypocalcemia and Hypophosphatemia

Severe hypocalcemia (corrected serum calcium less than 7 mg/dL or less than 1.75 mmol/L) and severe hypophosphatemia (serum phosphorus less than 2 mg/dL or less than 0.6 mmol/L) occurred in 2% and 21% patients treated with denosumab, respectively.

Osteonecrosis of the Jaw (ONJ)

In the primary treatment phase of Study 20090482, ONJ was confirmed in 4.1% of patients in the denosumab group (median exposure of 16 months; range: 1-50) and 2.8% of patients in the zoledronic acid group (median 15 months, range: 1-45 months). At the completion of the double-blind treatment

phase of Study 20090482, the patient-year adjusted incidence (number of events per 100 patient years) of confirmed ONJ in the denosumab group (median exposure of 19.4 months; range 1-52) was 2% during the first year of treatment, 5% in the second year, and 4.5% per year thereafter. The median time to ONJ was 18.7 months (range: 1-44) [*see Warnings and Precautions (5.4)*].

Giant Cell Tumor of Bone

The safety of denosumab was evaluated in two single-arm trials (Study 20062004 and Study 20040215) [*see Clinical Trials (14.3)*] in which a total of 548 adult or skeletally mature adolescent patients with giant cell tumor of bone received at least 1 dose of denosumab. Patients received 120 mg denosumab subcutaneously every 4 weeks with additional 120 mg doses on Days 8 and 15 of the first month of therapy. Patients receiving concurrent bisphosphonate therapy were excluded from enrollment in both studies. Patients with prior history of ONJ or osteomyelitis of the jaw, an active dental or jaw condition requiring oral surgery, non-healed dental/oral surgery, or any planned invasive dental procedure were excluded from enrollment in Study 20040215. During the trial, serum chemistries including calcium and phosphorus were monitored every 4 weeks. Calcium and vitamin D supplementation was recommended but not required.

Of the 548 patients who received denosumab, 467 patients were treated with denosumab for ≥ 1 year, 323 patients for ≥ 2 years, and 255 patients for ≥ 3 years. The median number of doses received was 33 (range: 4-138 doses) and the median number of months on-study was 60 (range: 0-140 months). Fifty-seven percent of the enrolled patients were women and 82% were White. The median age was 33 years (range: 13-83 years); a total of 19 patients were skeletally mature adolescents (12 to <17 years of age).

The common adverse reaction profile of denosumab in patients with giant cell tumor of bone was generally similar to that reported in Studies 20050136, 20050244, and 20050103. The most common adverse reactions in patients (incidence $\geq 10\%$) were arthralgia, back pain, pain in extremity, fatigue, headache, nausea, nasopharyngitis, musculoskeletal pain, toothache, vomiting, hypophosphatemia, constipation, diarrhea, and cough. The most frequent serious adverse reactions were osteonecrosis of the jaw (3.6%), bone giant cell tumor (1.5%), anemia (1.1%), pneumonia (0.9%), and back pain (0.9%). The most frequent adverse reactions resulting in discontinuation of denosumab was osteonecrosis of the jaw (incidence of 3.6%). The adverse reaction profile appeared similar in skeletally mature adolescents and adults.

Hypocalcemia and Hypophosphatemia

- Moderate to severe hypocalcemia (corrected serum calcium less than 8 mg/dL or less than 2 mmol/L) occurred in 5% of patients treated with denosumab.
- Severe hypophosphatemia (serum phosphorus less than 2 to 1 mg/dL or less than 0.6 to 0.3 mmol/L)

occurred in 20% of patients treated with denosumab.

Osteonecrosis of the Jaw (ONJ)

In the pooled analysis of Study 20062004 and Study 20040215, ONJ was confirmed in 7% of patients who received denosumab (median number of doses received: 33; range: 4-138 doses).

Study 20140114 (NCT03301857) was a 5-year long term follow-up study for patients (n=85) who completed Study 20062004. In Study 20062004 and Study 20140114 combined, ONJ was confirmed in 7% of patients who received denosumab (median time on trial 62.2 months (range 0 – 173)). The combined patient-year adjusted incidence (number of events per 100 patient years) of confirmed ONJ was 0.2% during the first year of treatment, 1.5% in the second year, 1.8% in the third year, 2.1% in the fourth year, 1.4% in the fifth year, and 1.5% thereafter [*see Warnings and Precautions (5.4)*].

Atypical Subtrochanteric and Diaphyseal Fracture

In the pooled analysis of Study 20062004 and Study 20040215, atypical femoral fracture was observed in 0.9% of patients who received denosumab (median number of doses received: 33; range: 4-138 doses).

In Study 20062004 and Study 20140114, the combined incidence of confirmed atypical femoral fracture was 1.3% of patients who received denosumab [*see Warnings and Precautions (5.5)*].

Hypercalcemia Following Treatment Discontinuation

In the pooled safety population, 0.7% of patients experienced serious adverse events of hypercalcemia > 30 days following treatment discontinuation that was recurrent in some patients [*see Warnings and Precautions (5.6)*].

Hypercalcemia of Malignancy

Denosumab was evaluated in an open-label, single-arm trial (Study 20070315) in which 33 patients with hypercalcemia of malignancy (with or without bone metastases) refractory to treatment with intravenous bisphosphonate therapy were enrolled [*see Clinical Trials (14.4)*].

The adverse reaction profile of denosumab in patients with hypercalcemia of malignancy was similar to that reported in Studies 20050136, 20050244, 20050103, 20062004, and 20040215. Adverse reactions occurring in greater than 20% of patients were nausea (30%), dyspnea (27%), decreased appetite (24%), headache (24%), peripheral edema (24%), vomiting (24%), anemia (21%), constipation (21%), and diarrhea (21%). The following adverse reactions of Grade 3 or greater severity related to study therapy were reported on-study: fatigue (3%) and infection (6%). Grade 3 laboratory abnormalities included hypomagnesemia (3%), hypokalemia (3%), and hypophosphatemia (76%) of patients. No deaths on-study

were related to denosumab therapy.

6.2 Postmarketing Experience

The following adverse reactions have been identified during post-approval use of denosumab products. Because these reactions are reported voluntarily from a population of uncertain size, it is not always possible to reliably estimate their frequency or establish a causal relationship to drug exposure.

- Hypocalcemia: Severe symptomatic hypocalcemia, including fatal cases [*see Contraindications (4.1) and Warnings and Precautions (5.3)*].
- Hypercalcemia: Severe symptomatic hypercalcemia following treatment discontinuation can occur [*see Adverse Reactions (6) and Warnings and Precautions (5.6)*].
- Hypersensitivity, including anaphylactic reactions [*see Contraindications (4.2) and Warnings and Precautions (5.2)*].
- Musculoskeletal pain, including severe musculoskeletal pain. Positive re-challenge has been reported.
- Lichenoid drug eruptions (e.g., lichen planus-like reactions).
- Alopecia.

8 USE IN SPECIFIC POPULATIONS

8.1 Pregnancy

Risk Summary

Based on findings in animals and its mechanism of action, denosumab products can cause fetal harm when administered to a pregnant woman [*see Clinical Pharmacology (12.1)*]. There are insufficient data with denosumab products use in pregnant women to inform any drug associated risks for adverse developmental outcomes. *In utero* denosumab exposure from cynomolgus monkeys dosed monthly with denosumab throughout pregnancy at a dose 25-fold higher than the recommended human dose of denosumab based on body weight resulted in increased fetal loss, stillbirths, and postnatal mortality; and absent lymph nodes, abnormal bone growth, and decreased neonatal growth [*see Data*].

Apprise pregnant women of the potential risk to the fetus.

The background rate of major birth defects and miscarriage is unknown for the indicated population. In the U.S. general population, the estimated background risk of major birth defects and miscarriage in clinically recognized pregnancies is 2-4% and 15-20%, respectively.

Data

Animal Data

The effects of denosumab on prenatal development have been studied in both cynomolgus monkeys and genetically engineered mice in which RANK ligand (RANKL) expression was turned off by gene removal (a “knockout mouse”). In cynomolgus monkeys dosed subcutaneously with denosumab throughout pregnancy starting at gestational day 20 and at a pharmacologically active dose 25-fold higher than the recommended human dose of denosumab based on body weight, there was increased fetal loss during gestation, stillbirths, and postnatal mortality. Other findings in offspring included absence of axillary, inguinal, mandibular, and mesenteric lymph nodes; abnormal bone growth, reduced bone strength, reduced hematopoiesis, dental dysplasia, and tooth malalignment; and decreased neonatal growth. At birth out to one month of age, infants had measurable blood levels of denosumab (22-621% of maternal levels).

Following a recovery period from birth out to 6 months of age, the effects on bone quality and strength returned to normal; there were no adverse effects on tooth eruption, though dental dysplasia was still apparent; axillary and inguinal lymph nodes remained absent, while mandibular and mesenteric lymph nodes were present, though small; and minimal to moderate mineralization in multiple tissues was seen in one recovery animal. There was no evidence of maternal harm prior to labor; adverse maternal effects occurred infrequently during labor. Maternal mammary gland development was normal. There was no fetal NOAEL (no observable adverse effect level) established for this study because only one dose of 50 mg/kg was evaluated. Mammary gland histopathology at 6 months of age was normal in female offspring exposed to denosumab *in utero*; however, development and lactation have not been fully evaluated.

In RANKL knockout mice, absence of RANKL (the target of denosumab) also caused fetal lymph node agenesis and led to postnatal impairment of dentition and bone growth. Pregnant RANKL knockout mice showed altered maturation of the maternal mammary gland, leading to impaired lactation [*see Use in Specific Populations (8.3) and Nonclinical Toxicology (13.2)*].

8.2 Lactation

Risk Summary

There is no information regarding the presence of denosumab products in human milk, the effects on the breastfed child, or the effects on milk production. Denosumab was detected in the maternal milk of cynomolgus monkeys up to 1 month after the last dose of denosumab ($\leq 0.5\%$ milk:serum ratio) and maternal mammary gland development was normal, with no impaired lactation. However, pregnant RANKL knockout mice showed altered maturation of the maternal mammary gland, leading to impaired lactation [*see Use in Specific Populations (8.1) and Nonclinical Toxicology (13.2)*]. Consider the developmental and health benefits of breastfeeding along with the mother’s clinical need for Jubereq treatment and any potential adverse effects on the breastfed child from Jubereq or from the underlying

maternal condition.

8.3 Females and Males of Reproductive Potential

Based on findings in animals and its mechanism of action, denosumab products can cause fetal harm when administered to a pregnant woman [*see Use in Specific Populations (8.1)*].

Pregnancy Testing

Verify the pregnancy status of females of reproductive potential prior to initiating Jubereq treatment.

Contraception

Females

Advise females of reproductive potential to use effective contraception during therapy, and for at least 5 months after the last dose of Jubereq.

8.4 Pediatric Use

The safety and efficacy of Jubereq have not been established in pediatric patients except in skeletally mature adolescents (aged 12–16 years) with giant cell tumor of bone. Jubereq is recommended only for treatment of skeletally mature adolescents (aged 12–16 years) with giant cell tumor of bone [*see Indications and Usage (1.2)*]. Clinically significant hypercalcemia after treatment discontinuation has been reported in pediatric patients with growing skeletons who received denosumab products for giant cell tumor of bone or for unapproved indications [*see Adverse Reactions (6.2) and Warnings and Precautions (5.6)*].

Denosumab was studied in an open-label trial that enrolled a subset of 19 adolescent patients (aged 12-16 years) with giant cell tumor of bone who had reached skeletal maturity, defined by at least 1 mature long bone (e.g., closed epiphyseal growth plate of the humerus), and had a body weight ≥ 45 kg [*see Indications and Usage (1.2) and Clinical Trials (14.3)*]. A total of one of five (20%) evaluable adolescent patients had an objective response by retrospective independent assessment of radiographic response according to modified Response Evaluation Criteria in Solid Tumors (RECIST 1.1). The adverse reaction profile and efficacy results appeared to be similar in skeletally mature adolescents and adults [*see Adverse Reactions (6.1) and Clinical Trials (14.3)*].

Animal Data

Treatment with denosumab products may impair bone growth in children with open growth plates and may inhibit eruption of dentition. In neonatal rats, inhibition of RANKL (the target of denosumab therapy) with a construct of osteoprotegerin bound to Fc (OPG-Fc) at doses ≤ 10 mg/kg was associated with inhibition of bone growth and tooth eruption. Adolescent primates treated with denosumab at doses

5 and 25 times (10 and 50 mg/kg dose) higher than the recommended human dose of 120 mg administered once every 4 weeks, based on body weight (mg/kg), had abnormal growth plates, considered to be consistent with the pharmacological activity of denosumab.

Cynomolgus monkeys exposed *in utero* to denosumab exhibited bone abnormalities, reduced hematopoiesis, tooth malalignment, decreased neonatal growth, and an absence of axillary, inguinal mandibular, and mesenteric lymph nodes. Some bone abnormalities recovered once exposure was ceased following birth; however, axillary and inguinal lymph nodes remained absent 6 months post-birth [see *Use in Specific Populations (8.1)*].

8.5 Geriatric Use

Of the total number of patients in clinical studies that received denosumab (n = 2841) in Studies 20050136, 20050244, and 20050103, 1271 (44%) were \geq 65 years old, while 473 patients (17%) were \geq 75 years old. Of the 859 patients in Study 20090482 that received denosumab, 387 patients (45%) were \geq 65 years old, while 141 patients (16%) were \geq 75 years old. No overall differences in safety or efficacy were observed between older and younger patients.

8.6 Renal Impairment

Two clinical trials were conducted in patients without cancer and with varying degrees of renal function.

In one study, patients (N = 55) with varying degrees of renal function (ranging from normal through end-stage renal disease requiring dialysis) received a single 60 mg subcutaneous dose of denosumab. In a second study, patients (N = 32) with severe renal dysfunction (creatinine clearance less than 30 mL/min and/or on dialysis) were given two 120 mg subcutaneous doses of denosumab. In both studies, greater risk of developing hypocalcemia was observed with increasing renal impairment, and with inadequate/no calcium supplementation. Hypocalcemia was mild to moderate in severity in 96% of patients. Monitor calcium levels and calcium and vitamin D intake [see *Warnings and Precautions (5.3)*, *Adverse Reactions (6.1)*, and *Clinical Pharmacology (12.3)*].

10 OVERDOSAGE

There is no experience with overdosage of denosumab products.

11 DESCRIPTION

Denosumab-desu is a human IgG2 monoclonal antibody that binds to human RANKL. Denosumab-desu has an approximate molecular weight of 147 kDa and is produced in genetically engineered mammalian (Chinese hamster ovary) cells.

Jubereq (denosumab-desu) injection is a sterile, preservative-free, clear, colorless to pale yellow solution

for subcutaneous use.

Each single-dose vial contains 1.7 mL solution of 120 mg denosumab-desu, 1.84 mg glacial acetic acid, 0.17 mg polysorbate 20, 78.2 mg sorbitol, Water for Injection, and sodium hydroxide to adjust to a pH of 5.2.

12 CLINICAL PHARMACOLOGY

12.1 Mechanism of Action

Denosumab products bind to RANKL, a transmembrane or soluble protein essential for the formation, function, and survival of osteoclasts, the cells responsible for bone resorption, thereby modulating calcium release from bone. Increased osteoclast activity, stimulated by RANKL, is a mediator of bone pathology in solid tumors with osseous metastases. Similarly, giant cell tumors of bone consist of stromal cells expressing RANKL and osteoclast-like giant cells expressing RANK receptor, and signaling through the RANK receptor contributes to osteolysis and tumor growth. Denosumab products prevent RANKL from activating its receptor, RANK, on the surface of osteoclasts, their precursors, and osteoclast-like giant cells.

12.2 Pharmacodynamics

In patients with breast cancer and bone metastases, the median reduction in uNTx/Cr was 82% within 1 week following initiation of denosumab 120 mg administered subcutaneously. In Studies 20050136, 20050244, and 20050103, the median reduction in uNTx/Cr from baseline to Month 3 was approximately 80% in 2075 denosumab-treated patients.

In a phase 3 study of patients with newly diagnosed multiple myeloma who received subcutaneous doses of denosumab 120 mg every 4 weeks (Q4W), median reductions in uNTx/Cr of approximately 75% were observed by Week 5. Reductions in bone turnover markers were maintained, with median reductions of 74% to 79% for uNTx/Cr from weeks 9 to 49 of continued 120 mg Q4W dosing.

In adult and skeletally mature adolescent patients with giant cell tumor of bone who received subcutaneous doses of denosumab 120 mg Q4W with a 120 mg loading dose on Days 8 and 15, median reductions in uNTx/Cr from baseline were 84% at Week 13 and 82% at Week 25.

12.3 Pharmacokinetics

Following subcutaneous administration, bioavailability was 62%. Denosumab displayed nonlinear pharmacokinetics at doses below 60 mg, but approximately dose-proportional increases in exposure at higher doses.

With multiple subcutaneous doses of 120 mg once every 4 weeks, up to 2.8-fold accumulation in serum denosumab concentrations was observed and steady-state was achieved by 6 months. A mean (\pm standard deviation) serum steady-state trough concentration of 20.5 (\pm 13.5) mcg/mL was achieved by 6 months. The mean elimination half-life was 28 days.

In patients with newly diagnosed multiple myeloma who received 120 mg every 4 weeks, denosumab concentrations appear to reach steady-state by Month 6. In patients with giant cell tumor of bone, after administration of subcutaneous doses of 120 mg once every 4 weeks with additional 120 mg doses on Days 8 and 15 of the first month of therapy, mean (\pm standard deviation) serum trough concentrations on Day 8, 15, and one month after the first dose were 19.0 (\pm 24.1), 31.6 (\pm 27.3), 36.4 (\pm 20.6) mcg/mL, respectively. Steady-state was achieved in 3 months after initiation of treatment with a mean serum trough concentration of 23.4 (\pm 12.1) mcg/mL.

Special Populations

Body Weight: A population pharmacokinetic analysis was performed to evaluate the effects of demographic characteristics. Denosumab clearance and volume of distribution were proportional to body weight. The steady-state exposure following repeat subcutaneous administration of 120 mg every 4 weeks to 45 kg and 120 kg subjects were, respectively, 48% higher and 46% lower than exposure of the typical 66 kg subject.

Age, Gender and Race: The pharmacokinetics of denosumab was not affected by age, gender, and race.

Pediatrics: In skeletally-mature adolescent patients (12 to 16 years of age) with giant cell tumor of bone (GCTB) who received 120 mg every 4 weeks with a 120 mg loading dose on Days 8 and 15, the pharmacokinetics of denosumab were comparable to those observed in adult patients with GCTB.

Hepatic Impairment: No clinical trials have been conducted to evaluate the effect of hepatic impairment on the pharmacokinetics of denosumab products.

Renal Impairment: In clinical trials of 87 patients with varying degrees of renal dysfunction, including patients on dialysis, the degree of renal impairment had no effect on the pharmacokinetics and pharmacodynamics of denosumab [see *Use in Specific Populations (8.6)*].

Drug Interactions

No formal drug-drug interaction trials have been conducted with denosumab. There was no evidence that various anticancer treatments affected denosumab systemic exposure and pharmacodynamic effect. Serum denosumab concentrations at 1 and 3 months and reductions in the bone turnover marker uNTx/Cr

(urinary N-terminal telopeptide corrected for creatinine) at 3 months were similar in patients with and without prior intravenous bisphosphonate therapy and were not altered by concomitant chemotherapy and/or hormone therapy.

12.6 Immunogenicity

The observed incidence of anti-drug antibodies is highly dependent on the sensitivity and specificity of the assay. Differences in assay methods preclude meaningful comparisons of the incidence of anti-drug antibodies in the studies described below with the incidence of anti-drug antibodies in other studies, including those of denosumab or of other denosumab products.

Using an electrochemiluminescent bridging immunoassay, less than 1% (55 out of 8113) of patients treated with denosumab for up to 5 years tested positive for binding antibodies (including pre-existing, transient, and developing antibodies). None of the patients tested positive for neutralizing antibodies, as was assessed using a chemiluminescent cell-based in vitro biological assay. There was no identified clinically significant effect of anti-drug antibodies on pharmacokinetics, pharmacodynamics, safety, or effectiveness of denosumab.

13 NONCLINICAL TOXICOLOGY

13.1 Carcinogenesis, Mutagenesis, Impairment of Fertility

Carcinogenicity

The carcinogenic potential of denosumab products has not been evaluated in long-term animal studies.

Mutagenicity

The genotoxic potential of denosumab products has not been evaluated.

Impairment of Fertility

Denosumab had no effect on female fertility or male reproductive organs in monkeys at doses that were 6.5- to 25-fold higher than the recommended human dose of 120 mg subcutaneously administered once every 4 weeks, based on body weight (mg/kg).

13.2 Animal Toxicology and/or Pharmacology

Denosumab products are inhibitors of osteoclastic bone resorption via inhibition of RANKL.

Because the biological activity of denosumab in animals is specific to nonhuman primates, evaluation of genetically engineered (knockout) mice or use of other biological inhibitors of the RANK/RANKL pathway, OPG-Fc and RANK-Fc, provided additional information on the pharmacodynamic properties of denosumab. RANK/RANKL knockout mice exhibited absence of lymph node formation, as well as an

absence of lactation due to inhibition of mammary gland maturation (lobulo-alveolar gland development during pregnancy). Neonatal RANK/RANKL knockout mice exhibited reduced bone growth and lack of tooth eruption. A corroborative study in 2-week-old rats given the RANKL inhibitor OPG-Fc also showed reduced bone growth, altered growth plates, and impaired tooth eruption. These changes were partially reversible in this model when dosing with the RANKL inhibitors was discontinued.

14 CLINICAL TRIALS

14.1 Bone Metastasis from Solid Tumors

The safety and efficacy of denosumab for the prevention of skeletal-related events in patients with bone metastases from solid tumors was demonstrated in three international, randomized (1:1), double-blind, active-controlled, noninferiority trials comparing denosumab with zoledronic acid. In all three trials, patients were randomized to receive 120 mg denosumab subcutaneously every 4 weeks or 4 mg zoledronic acid intravenously (IV) every 4 weeks (dose adjusted for reduced renal function). Patients with creatinine clearance less than 30 mL/min were excluded. In each trial, the main outcome measure was demonstration of noninferiority of time to first skeletal-related event (SRE) as compared to zoledronic acid. Supportive outcome measures were superiority of time to first SRE and superiority of time to first and subsequent SRE; testing for these outcome measures occurred if the main outcome measure was statistically significant. An SRE was defined as any of the following: pathologic fracture, radiation therapy to bone, surgery to bone, or spinal cord compression.

Study 20050136 (NCT00321464) enrolled 2046 patients with advanced breast cancer and bone metastasis. Randomization was stratified by a history of prior SRE (yes or no), receipt of chemotherapy within 6 weeks prior to randomization (yes or no), prior oral bisphosphonate use (yes or no), and region (Japan or other countries). Forty percent of patients had a previous SRE, 40% received chemotherapy within 6 weeks prior to randomization, 5% received prior oral bisphosphonates, and 7% were enrolled from Japan. Median age was 57 years, 80% of patients were White, and 99% of patients were women. The median number of doses administered was 18 for denosumab and 17 for zoledronic acid.

Study 20050244 (NCT00330759) enrolled 1776 adults with solid tumors other than breast and castrate-resistant prostate cancer with bone metastasis and multiple myeloma. Randomization was stratified by previous SRE (yes or no), systemic anticancer therapy at time of randomization (yes or no), and tumor type (non-small cell lung cancer, myeloma, or other). Eighty-seven percent were receiving systemic anticancer therapy at the time of randomization, 52% had a previous SRE, 64% of patients were men, 87% were White, and the median age was 60 years. A total of 40% of patients had non-small cell lung cancer, 10% had multiple myeloma, 9% had renal cell carcinoma, and 6% had small cell lung cancer. Other tumor types each comprised less than 5% of the enrolled population. The median number of doses administered was 7 for both denosumab and zoledronic acid.

Study 20050103 (NCT00321620) enrolled 1901 men with castrate-resistant prostate cancer and bone metastasis. Randomization was stratified by previous SRE, PSA level (less than 10 ng/mL or 10 ng/mL or greater) and receipt of chemotherapy within 6 weeks prior to randomization (yes or no). Twenty-six percent of patients had a previous SRE, 15% of patients had PSA less than 10 ng/mL, and 14% received chemotherapy within 6 weeks prior to randomization. Median age was 71 years and 86% of patients were White. The median number of doses administered was 13 for denosumab and 11 for zoledronic acid.

Denosumab delayed the time to first SRE following randomization as compared to zoledronic acid in patients with breast or castrate-resistant prostate cancer (CRPC) with osseous metastases (Table 2). In patients with bone metastasis due to other solid tumors or lytic lesions due to multiple myeloma, denosumab was noninferior to zoledronic acid in delaying the time to first SRE following randomization. Overall survival and progression-free survival were similar between arms in all three trials.

Table 2. Efficacy Results for Denosumab Compared to Zoledronic Acid

	Study 20050136 Metastatic Breast Cancer		Study 20050244 Metastatic Solid Tumors or Multiple Myeloma		Study 20050103 Metastatic CRPC ^a	
	Denosumab N = 1026	Zoledronic Acid N = 1020	Denosumab N = 886	Zoledronic Acid N = 890	Denosumab N = 950	Zoledronic Acid N = 951
First On-study SRE						
Number of Patients who had SREs (%)	315 (30.7)	372 (36.5)	278 (31.4)	323 (36.3)	341 (35.9)	386 (40.6)
Components of First SRE						
Radiation to Bone	82 (8.0)	119 (11.7)	119 (13.4)	144 (16.2)	177 (18.6)	203 (21.3)
Pathological Fracture	212 (20.7)	238 (23.3)	122 (13.8)	139 (15.6)	137 (14.4)	143 (15.0)
Surgery to Bone	12 (1.2)	8 (0.8)	13 (1.5)	19 (2.1)	1 (0.1)	4 (0.4)
Spinal Cord Compression	9 (0.9)	7 (0.7)	24 (2.7)	21 (2.4)	26 (2.7)	36 (3.8)
Median Time to SRE (months)	NR ^b	26.4	20.5	16.3	20.7	17.1
Hazard Ratio (95% CI)	0.82 (0.71, 0.95)		0.84 (0.71, 0.98)		0.82 (0.71, 0.95)	
Noninferiority p-value	< 0.001		<0.001		<0.001	
Superiority p-value ^c	0.010		0.060		0.008	
First and Subsequent SRE^d						
Mean Number/Patient	0.46	0.60	0.44	0.49	0.52	0.61
Rate Ratio (95% CI)	0.77 (0.66, 0.89)		0.90 (0.77, 1.04)		0.82 (0.71, 0.94)	
Superiority p-value ^e	0.001		0.145		0.009	

^a CRPC = castrate-resistant prostate cancer.

^b NR = not reached.

^c Superiority testing performed only after denosumab demonstrated to be noninferior to zoledronic acid within trial.

^d All skeletal events postrandomization; new events defined by occurrence \geq 21 days after preceding event.

^e Adjusted p-values are presented.

14.2 Multiple Myeloma

The efficacy of denosumab for the prevention of skeletal-related events in newly diagnosed multiple myeloma patients with treatment through disease progression, was evaluated in Study 20090482 (NCT01345019), an international, randomized (1:1), double-blind, active-controlled, noninferiority trial comparing denosumab with zoledronic acid. In this trial, patients were randomized to receive 120 mg denosumab subcutaneously every 4 weeks or 4 mg zoledronic acid intravenously (IV) every 4 weeks

(dose adjusted for reduced renal function). Patients with creatinine clearance less than 30 mL/min were excluded. In this trial, the main efficacy outcome measure was noninferiority of time to first skeletal-related event (SRE). Additional efficacy outcome measures were superiority of time to first SRE, time to first and subsequent SRE, and overall survival. An SRE was defined as any of the following: pathologic fracture, radiation therapy to bone, surgery to bone, or spinal cord compression.

Study 20090482 enrolled 1718 newly diagnosed multiple myeloma patients with bone lesions. Randomization was stratified by a history of prior SRE (yes or no), the anti-myeloma agent being utilized/planned to be utilized in first-line therapy (novel therapy-based or non-novel therapy-based [novel therapies include bortezomib, lenalidomide, or thalidomide]), intent to undergo autologous PBSC transplantation (yes or no), stage at diagnosis (International Staging System I or II or III) and region Japan (yes or no). At study enrollment, 96% of the patients were receiving or planning to receive novel therapy-based first-line anti-myeloma therapy, 55% of the patients intended to undergo autologous PBSC transplantation, 61% of patients had a previous SRE, 32% were at ISS Stage I, 38% were at ISS Stage II and 29% were at ISS Stage III, and 2% were enrolled from Japan. Median age was 63 years, 82% of patients were White, and 46% of patients were women. The median number of doses administered was 16 for denosumab and 15 for zoledronic acid.

Denosumab was noninferior to zoledronic acid in delaying the time to first SRE following randomization (HR = 0.98, 95% CI, 0.85-1.14). The results for overall survival (OS) were comparable between denosumab and zoledronic acid treatment groups with a hazard ratio of 0.90 (95% CI: 0.70, 1.16).

Table 3. Efficacy Results for Denosumab Compared to Zoledronic Acid

	Study 20090482 Multiple Myeloma	
	Denosumab N = 859	Zoledronic Acid N = 859
First On-study SRE		
Number of Patients who had SREs (%)	376 (43.8)	383 (44.6)
Components of First SRE		
Radiation to Bone	47 (5.5)	62 (7.2)
Pathological Fracture	342 (39.8)	338 (39.3)
Surgery to Bone	37 (4.3)	48 (5.6)
Spinal Cord Compression	6 (0.7)	4 (0.5)
Median Time to SRE (months) (95% CI)	22.8 (14.7, NE ^a)	24 (16.6, 33.3)
Hazard Ratio (95% CI)	0.98 (0.85, 1.14)	

^a NE = not estimable

14.3 Giant Cell Tumor of Bone

The safety and efficacy of denosumab for the treatment of giant cell tumor of bone in adults or skeletally mature adolescents were demonstrated in two open-label trials [Study 20040215 (NCT00396279) and Study 20062004 (NCT00680992)] that enrolled patients with histologically confirmed measurable giant cell tumor of bone that was either recurrent, unresectable, or for which planned surgery was likely to result in severe morbidity. Patients received 120 mg denosumab subcutaneously every 4 weeks with a loading dose on Days 8 and 15 of the first cycle of therapy. Patients who discontinued denosumab then entered the safety follow-up phase for a minimum of 60 months. Retreatment with denosumab while in safety follow-up was allowed for patients who initially demonstrated a response to denosumab (e.g., in the case of recurrent disease).

Study 20040215 was a single-arm, pharmacodynamic, and proof of concept trial conducted in 37 adult patients with unresectable or recurrent giant cell tumor of bone. Patients were required to have histologically confirmed giant cell tumor of bone and radiologic evidence of measurable disease from a computed tomography (CT) or magnetic resonance imaging (MRI) obtained within 28 days prior to study enrollment. Patients enrolled in Study 20040215 underwent CT or MRI assessment of giant cell tumor of bone at baseline and quarterly during denosumab treatment.

Study 20062004 was a parallel-cohort, proof of concept, and safety trial conducted in 535 adult or skeletally mature adolescent patients with histologically confirmed giant cell tumor of bone and evidence of measurable active disease. Study 20062004 enrolled 19 patients who were 12-16 years of age [*see Use in Specific Populations (8.4)*]. Patients enrolled into one of three cohorts: Cohort 1 enrolled 268 patients with surgically unsalvageable disease (e.g., sacral or spinal sites of disease, or pulmonary metastases); Cohort 2 enrolled 252 patients with surgically salvageable disease where the investigator determined that the planned surgery was likely to result in severe morbidity (e.g., joint resection, limb amputation, or hemipelvectomy); Cohort 3 enrolled 15 patients who previously participated in Study 20040215. Patients underwent imaging assessment of disease status at intervals determined by their treating physician.

A retrospective interim analysis concluded by an independent review committee evaluated objective response in 187 patients enrolled and treated in Study 20040215 and Study 20062004 for whom baseline and at least one post-baseline radiographic assessment were available (27 of 37 patients enrolled in Study 20040215 and 160 of 270 patients enrolled in Cohorts 1 and 2 of Study 20062004). The primary efficacy outcome measure was objective response rate using Response Evaluation Criteria in Solid Tumors (RECIST) v 1.1.

The overall objective response rate (RECIST 1.1) was 25% (95% CI: 19, 32). All responses were partial responses. The estimated median time to response was 3 months. In the 47 patients with an objective response, the median duration of follow-up was 20 months (range: 2-44 months), and 51% (24/47) had a duration of response lasting at least 8 months. Three patients experienced disease progression following

an objective response.

14.4 Hypercalcemia of Malignancy

The safety and efficacy of denosumab was demonstrated in an open-label, single-arm trial [Study 20070315 (NCT00896454)] that enrolled 33 patients with hypercalcemia of malignancy (with or without bone metastases) refractory to treatment with intravenous bisphosphonate therapy. Patients received denosumab subcutaneously every 4 weeks with additional 120 mg doses on Days 8 and 15 of the first month of therapy.

In this trial, refractory hypercalcemia of malignancy was defined as an albumin-corrected calcium of > 12.5 mg/dL (3.1 mmol/L) despite treatment with intravenous bisphosphonate therapy in 7-30 days prior to initiation of denosumab therapy. The primary outcome measure was the proportion of patients achieving a response, defined as corrected serum calcium (CSC) \leq 11.5 mg/dL (2.9 mmol/L), within 10 days after denosumab administration. Efficacy data are summarized in Figure 1 and Table 4. Concurrent chemotherapy did not appear to affect response to denosumab.

Figure 1. Corrected Serum Calcium by Visit in Responders (Median and Interquartile Range)

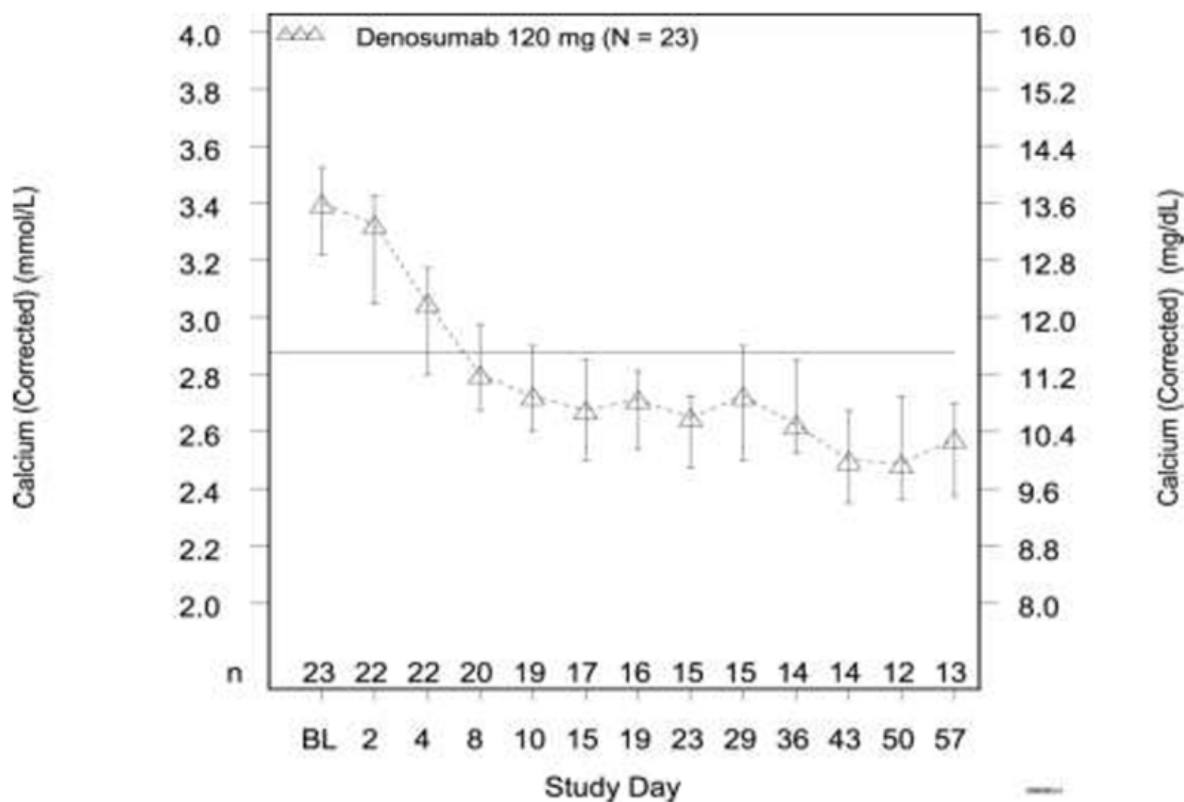

N= Number of responders who received \geq 1 dose of investigational product

n = Number of responders who had no missing data at baseline and the time point of interest

Table 4. Efficacy in Patients with Hypercalcemia of Malignancy Refractory to Bisphosphonate Therapy

	N=33	Proportion (%) (95% CI)
All Responders (CSC ≤ 11.5 mg/dL) by Day 10	21	63.6 (45.1, 79.6)
All Responders by Day 57	23	69.7 (51.3, 84.4)
Complete Responders (CSC ≤ 10.8 mg/dL) by Day 10	12	36.4 (20.4, 54.9)
All Complete Responders by Day 57	21	63.6 (45.1, 79.6)

Median time to response (CSC ≤ 11.5 mg/dL) was 9 days (95% CI: 8, 19), and the median duration of response was 104 days (95% CI: 7, not estimable). Median time to complete response (CSC ≤ 10.8 mg/dL) was 23 days (95% CI: 9, 36), and the median duration of complete response was 34 days (95% CI: 1, 134).

16 HOW SUPPLIED/STORAGE AND HANDLING

Jubereq (denosumab-desu) injection is a clear and colorless to pale yellow solution supplied in a single-dose vial.

120 mg/1.7 mL (70 mg/mL) in a single-dose vial	1 vial per carton	NDC 69448-022-63
--	-------------------	------------------

Store Jubereq refrigerated at 2°C to 8°C (36°F to 46°F) in the original carton to protect from light. Do not freeze. Prior to administration, Jubereq may be allowed to reach room temperature up to 25°C (77°F) in the original container. Once removed from the refrigerator, Jubereq must not be exposed to temperatures above 25°C (77°F) and must be used within 14 days. Discard Jubereq if not used within the 14 days. Do not use Jubereq after the expiry date printed on the label.

Protect Jubereq from direct light and heat.

Avoid vigorous shaking of Jubereq.

17 PATIENT COUNSELING INFORMATION

Drug Products with Same Active Ingredient

Advise patients that if they receive Jubereq, they should not receive other denosumab products concomitantly [see *Warnings and Precautions* (5.1)].

Hypersensitivity

Advise patients to seek prompt medical attention if signs or symptoms of hypersensitivity reactions occur. Advise patients who have had signs or symptoms of systemic hypersensitivity reactions that they should not receive denosumab products [see *Warnings and Precautions (5.2) and Contraindications (4.2)*].

Hypocalcemia

Adequately supplement patients with calcium and vitamin D and instruct them on the importance of maintaining serum calcium levels while receiving Jubereq [see *Warnings and Precautions (5.3) and Use in Specific Populations (8.6)*]. Advise patients to seek prompt medical attention if they develop signs or symptoms of hypocalcemia.

Osteonecrosis of the Jaw

Advise patients to maintain good oral hygiene during treatment with Jubereq and to inform their dentist prior to dental procedures that they are receiving Jubereq. Patients should avoid invasive dental procedures during treatment with Jubereq and inform their healthcare provider or dentist if they experience persistent pain and/or slow healing of the mouth or jaw after dental surgery [see *Warnings and Precautions (5.4)*].

Atypical Subtrochanteric and Diaphyseal Femoral Fracture

Advise patients to report new or unusual thigh, hip, or groin pain [see *Warnings and Precautions (5.5)*].

Hypercalcemia Following Treatment Discontinuation in Patients with Giant Cell Tumor of Bone and in Patients with Growing Skeletons

Advise patients to report nausea, vomiting, headache, and decreased alertness following treatment discontinuation [see *Warnings and Precautions (5.6) and Use in Specific Populations (8.4)*].

Multiple Vertebral Fractures (MVF) Following Treatment Discontinuation

Advise patients that after treatment with Jubereq is stopped there may be an increased risk of having broken bones in the spine especially in patients who have had a fracture or who have had osteoporosis. Advise patients not to interrupt Jubereq therapy without their physician's advice [see *Warnings and Precautions (5.7)*].

Embryo-Fetal Toxicity

Advise females of reproductive potential that Jubereq can cause harm to a fetus and to inform their healthcare provider of a known or suspected pregnancy [see *Warnings and Precautions (5.8) and Use in Specific Populations (8.1, 8.3)*].

Advise females of reproductive potential to use effective contraception during treatment and for at least 5 months after the last dose of Jubereq [see *Use in Specific Populations (8.3)*].



Jubereq (denosumab-desu)

Manufactured by:

Accord BioPharma Inc.
8041 Arco Corporate Drive,
Suite 200, Raleigh, NC, USA 27617
U.S. License No. 2105